



Penguin Edge™ VXS1-RTM1

Installation and Use

P/N: 6806800P46E

July 2022



Legal Disclaimer*

SMART Embedded Computing, Inc. (SMART EC), dba Penguin Solutions™, assumes no responsibility for errors or omissions in these materials. **These materials are provided "AS IS" without warranty of any kind, either expressed or implied, including but not limited to, the implied warranties of merchantability, fitness for a particular purpose, or non-infringement.** SMART EC further does not warrant the accuracy or completeness of the information, text, graphics, links, or other items contained within these materials. SMART EC shall not be liable for any special, indirect, incidental, or consequential damages, including without limitation, lost revenues or lost profits, which may result from the use of these materials. SMART EC may make changes to these materials, or to the products described therein, at any time without notice. SMART EC makes no commitment to update the information contained within these materials.

Electronic versions of this material may be read online, downloaded for personal use, or referenced in another document as a URL to a SMART EC website. The text itself may not be published commercially in print or electronic form, edited, translated, or otherwise altered without the permission of SMART EC.

It is possible that this publication may contain reference to or information about SMART EC products, programming, or services that are not available in your country. Such references or information must not be construed to mean that SMART EC intends to announce such SMART EC products, programming, or services in your country.

Limited and Restricted Rights Legend

If the documentation contained herein is supplied, directly or indirectly, to the U.S. Government, the following notice shall apply unless otherwise agreed to in writing by SMART EC.

Use, duplication, or disclosure by the Government is subject to restrictions as set forth in subparagraph (b)(3) of the Rights in Technical Data clause at DFARS 252.227-7013 (Nov. 1995) and of the Rights in Noncommercial Computer Software and Documentation clause at DFARS 252.227-7014 (Jun. 1995).

SMART Embedded Computing, Inc., dba Penguin Solutions

2900 S. Diablo Way, Suite 190

Tempe, Arizona 85282

USA

*For full legal terms and conditions, visit <https://www.penguinsolutions.com/edge/legal/>

Table of Contents

About this Manual	7
Overview of Contents	7
Abbreviations	7
Conventions	11
Summary of Changes	13
Safety Notes	15
Sicherheitshinweise	19
1 Introduction	23
1.1 Overview	23
1.2 Features	23
1.3 Standard Compliances	23
1.4 Mechanical Data	24
1.5 Ordering and Support Information	24
2 Hardware Preparation and Installation	25
2.1 Overview	25
2.2 Unpacking and Inspecting the RTM	25
2.3 Requirements	25
2.3.1 Environmental Requirements	26
2.3.2 Power Requirements	27
2.4 Installing Rear Transition Module	27
3 Controls, LEDs, and Connectors	29
3.1 Overview	29
3.2 Front Panel	29
3.2.1 LEDs	30
3.2.1.1 Front Panel LEDs	30
3.2.2 Connectors	30
3.2.2.1 Connector Definitions	30
3.2.2.2 RTM Connectors	31
3.2.2.2.1 VME/VXS RP0 Connector	31

Table of Contents

3.2.2.2.2	VME RP2 Connector	33
3.2.2.2.3	RTM Mini Display Connector J1	36
3.2.2.2.4	RTM Serial Port 1 Connector J3	37
3.2.2.2.5	RTM Serial Port 2 Connector J2	37
3.2.2.2.6	RTM Serial Port 3 Connector P3	38
3.2.2.2.7	RTM Serial Port 4 Connector P4	38
3.2.2.2.8	RTM USB 1 and USB 2 Connector J4	39
3.2.2.2.9	RTM Dual Ethernet Connector J5	40
3.2.2.2.10	RTM eSATA Port 1 and 2 Connector J6	40
3.2.2.2.11	RTM PIM Connector J10	41
3.2.2.2.12	RTM PIM Connector J14	43
3.2.2.2.13	RTM Reset Connector P1	44
3.2.2.2.14	RTM CPLD Programming and Debug Connector P2	44
3.2.2.2.15	RTM GPIO Connector P5	45
3.2.3	Switches	45
3.2.3.1	RTM Configuration Switch	46
3.2.3.2	RTM FRU EEPROM	46
4	Functional Description	47
4.1	Overview	47
4.2	Block Diagram	47
4.3	Ethernet Interfaces	47
4.4	Serial COM Ports	47
4.5	USB Interface	48
4.6	Display Interface	48
4.7	SATA Interface	48
4.8	GPIO Interface	48
4.9	Power Supply Sources	48
A	Related Documentation	49
A.1	Penguin Solutions Documentation	49
A.2	Related Specifications	49
A.3	Manufacturers' Documents	50

List of Figures

Figure 3-1	Front Panel LEDs, Connectors, Switch	29
Figure 4-1	Block Diagram	47

List of Figures

List of Tables

Table 1-1	I/O Features List	23
Table 1-2	Board Standard Compliances	23
Table 1-3	Mechanical Data	24
Table 2-1	VXS1-RTM1 Specifications	26
Table 2-2	Operating Voltages	27
Table 2-3	Power Requirements	27
Table 3-1	Front Panel LEDs	30
Table 3-2	RTM Connectors	30
Table 3-3	RTM RP0 Connector Pin Assignment	32
Table 3-4	RP2 Pin Assignment	33
Table 3-5	RTM Mini Display Port Connector (J1)	36
Table 3-6	RTM COM 1 Connector (J3)	37
Table 3-7	RTM COM 2 Connector (J2)	37
Table 3-8	RTM COM 3 Header (P3)	38
Table 3-9	RTM COM 4 Header (P4)	38
Table 3-10	RTM Dual USB 1 and 2 Connector (J4)	39
Table 3-11	RTM Dual Ethernet Connector (J5)	40
Table 3-12	Dual eSATA Connector (J6)	40
Table 3-13	PIM Connector (J10)	41
Table 3-14	PIM Connector (J14)	43
Table 3-15	RTM Reset Switch Connector (P1)	44
Table 3-16	RTM CPLD Programming & Debug Header (P2)	44
Table 3-17	GPIO Header (P5)	45
Table 3-18	RTM Configuration Switch (S1)	46
Table A-1	Penguin Edge Documentation	49
Table A-2	Related Specifications	49
Table A-3	Manufacturer's Publications	50

List of Tables

About this Manual

Overview of Contents

This manual provides the information required to install and configure an VXS1-RTM1. Additionally, this manual provides specific preparation and installation information and data applicable to the board.

The VXS1-RTM1 is compatible with MVME8100 board.

This manual is divided into the following chapters and appendices:

Safety Notes, contains the cautions and warnings applicable to the use of this product.

Sicherheitshinweise, is a German translation of the Safety Notes chapter.

Chapter 1, Introduction, lists the features of the VXS1-RTM1 baseboard, standard compliances, and model numbers for boards and accessories.

Chapter 2, Hardware Preparation and Installation, includes a description of the VXS1-RTM1, unpacking instructions, environmental, thermal, and power requirements, and how to prepare and install the transition module.

Chapter 3, Controls, LEDs, and Connectors, provides an illustration of the board components and front panel details. This chapter also gives descriptions for the on-board and front panel LEDs and connectors.

Chapter 4, Functional Description, describes the major features of the VXS1-RTM1 baseboard. These descriptions include both programming and hardware characteristics of major components.

Appendix A, Related Documentation, provides listings for publications, manufacturer's documents and related industry specification for this product.

Abbreviations

This document uses the following abbreviations:

Term	Description
A	Amps
AC	Alternating Current
A/D	Analog/Digital

About this Manual

Term	Description
ANSI	American National Standard Institute
ASIC	Application Specific Integrated Circuit
BGA	Ball Grid Array
BLT	Block Transfer
CCB	Core Complex Bus
CE	Chip Enable
CFM	Cubic Feet per Minute
CHRP	(PowerPC) Common Hardware Reference Platform
CMC	Common Mezzanine Card
COM	Communications
COP	Common On-chip Processor
COTS	Commercial-Off-the-Shelf
CPLD	Complex Programmable Logic Device
CPU	Central Processing Unit
CRC	Cyclic Redundancy Check
DDR	Double Data Rate
oC	Degrees Celsius
DIMM	Dual In-line Memory Module
DLL	Delay-Locked Loop
DMA	Direct Memory Access
DRAM	Dynamic Random Access Memory
DUART	Dual Universal Asynchronous Receiver/Transmitter
ECC	Error Correction Code
EEPROM	Electrically Erasable Programmable Read-Only Memory
EPROM	Erasable Programmable Read-Only Memory
ETH	Ethernet

Term	Description
FCC	Federal Communications Commission
FEC	Fast Ethernet Controller
FIFO	First In First Out
F/W	Firmware
fpBGA	Flip chip Plastic Ball Grid Array
Gbit	Gigabit
Gbps	Gigabits Per Second
GMI	Gigabit Media Independent Interface
GPCM	General Purpose Chip select Machine
GPR	General Purpose Register
IDMA	Independent Direct Memory Access
I2C	Inter IC
IWD	Initial Hardware Watchdog
JTAG	Joint Test Access Group
KB	Kilobytes
KBAUD	Kilo Baud
LBC	Local Bus Controller
LSB	Least Significant Byte
MBLT	Multiplexed Block Transfer
Mbps	Megabits Per Second
MII	Media Independent Interface
MRAM	Magneto resistive random-access memory
MSB	Most Significant Byte
Msb	Most Significant Bit
MTBF	Mean Time Between Failure

About this Manual

Term	Description
NAND	(Not and) flash that is used for storage
NOR	(Not or) flash that is used for executing code
OSWD	OS Watchdog
PBGA	Plastic Ball Grid Array
PCI	Peripheral Component Interconnect
PCI-X	Peripheral Component Interconnect -X
PIC	Programmable Interrupt Controller
PIM	PCI Mezzanine Card Input/Output Module
PMC	PCI Mezzanine Card (IEEE P1386.1)
PLD	Programmable Logic Device
PLL	Phase-Locked Loop
POR	Power-On Reset
Ppm	Parts Per Million
PRD	Product Requirements Document
PReP	PowerPC Reference Platform
PrPMC	Processor PCI Mezzanine Card
QUART	Quad Universal Asynchronous Receiver/Transmitter
Rcv	Receive
RGMI	Reduced Gigabit Media Independent Interface
ROM	Read-Only Memory
RTBI	Reduced Ten Bit Interface
RTC	Real-Time Clock
RTM	Rear Transition Module
SATA	Serial AT Attachment
SBC	Single Board Computer
SDRAM	Synchronous Dynamic Random Access Memory





Term	Description
SMT	Surface Mount Technology
SODIMM	Small-Outline Dual In-line Memory Module
SPD	Serial Presence Detect
SRAM	Static Random Access Memory
TBD	To Be Determined
TBI	Ten Bit Interface
TSEC	Three-Speed Ethernet Controller
2eSST	Two edge Source Synchronous Transfer
UART	Universal Asynchronous Receiver/Transmitter
V	Volts
VIO	Input/Output Voltage
VITA	VMEbus International Trade Association
VME	VMEbus (Versa Module Eurocard)
VPD	Vital Product Data
W	Watts
Xmit	Transmit



Conventions

The following table describes the conventions used throughout this manual.

Notation	Description
0x00000000	Typical notation for hexadecimal numbers (digits are 0 through F), for example used for addresses and offsets
0b0000	Same for binary numbers (digits are 0 and 1)
bold	Used to emphasize a word
Screen	Used for on-screen output and code related elements or commands. Sample of Programming used in a table (9pt)

About this Manual

Notation	Description
Courier + Bold	Used to characterize user input and to separate it from system output
<i>Reference</i>	Used for references and for table and figure descriptions
File > Exit	Notation for selecting a submenu
<text>	Notation for variables and keys
[text]	Notation for software buttons to click on the screen and parameter description
...	Repeated item for example node 1, node 2, ..., node 12
.	Omission of information from example/command that is not necessary at the time
..	Ranges, for example: 0..4 means one of the integers 0,1,2,3, and 4 (used in registers)
	Logical OR
	Indicates a hazardous situation which, if not avoided, could result in death or serious injury
	Indicates a hazardous situation which, if not avoided, may result in minor or moderate injury
	Indicates a property damage message
	Indicates a hot surface that could result in moderate or serious injury
	Indicates an electrical situation that could result in moderate injury or death

Notation	Description
<p data-bbox="272 267 386 319">Use ESD protection</p> 	<p data-bbox="529 309 1300 366">Indicates that when working in an ESD environment care should be taken to use proper ESD practices</p>
	<p data-bbox="529 499 1186 526">No danger encountered, pay attention to important information</p>

Summary of Changes

Part Number	Publication Date	Description
6806800P46E	July 2022	Rebrand to Penguin Solutions.
6806800P46D	September 2019	Rebrand to SMART Embedded Computing
6806800P46C	April 2015	Rebrand to Artesyn template.
6806800P46B	November 2012	Updated <i>Standard Compliances on page 23</i> and <i>Requirements on page 25</i> .
6806800P46A	September 2012	First edition

Safety Notes

This section provides warnings that precede potentially dangerous procedures throughout this manual. Instructions contained in the warnings must be followed during all phases of operation, service, and repair of this equipment. You should also employ all other safety precautions necessary for the operation of the equipment in your operating environment. Failure to comply with these precautions or with specific warnings elsewhere in this manual could result in personal injury or damage to the equipment.

Penguin Solutions™ intends to provide all necessary information to install and handle the product in this manual. Because of the complexity of this product and its various uses, we do not guarantee that the given information is complete. If you need additional information, ask your Penguin Solutions representative.

This product is a Safety Extra Low Voltage (SELV) device designed to meet the EN60950-1 requirements for Information Technology Equipment. The use of the product in any other application may require safety evaluation specific to that application.

Only personnel trained by Penguin Solutions or persons qualified in electronics or electrical engineering are authorized to install, remove or maintain the product.

The information given in this manual is meant to complete the knowledge of a specialist and must not be used as replacement for qualified personnel.

Keep away from live circuits inside the equipment. Operating personnel must not remove equipment covers. Only Factory Authorized Service Personnel or other qualified service personnel may remove equipment covers for internal subassembly or component replacement or any internal adjustment.

Do not install substitute parts or perform any unauthorized modification of the equipment or the warranty may be voided. Contact your local Penguin Solutions representative for service and repair to make sure that all safety features are maintained.

EMC

This equipment has been tested and found to comply with the limits for a Class A digital device, pursuant to Part 15 of the FCC Rules. These limits are designed to provide reasonable protection against harmful interference when the equipment is operated in a commercial environment. This equipment generates, uses, and can radiate radio frequency energy and, if not installed and used in accordance with the instruction manual, may cause harmful interference to radio communications.

Operation of this equipment in a residential area is likely to cause harmful interference in which case the user will be required to correct the interference at his own expense. Changes or modifications not expressly approved by Penguin Solutions could void the user's authority to operate the equipment. Board products are tested in a representative

Safety Notes

system to show compliance with the above mentioned requirements. A proper installation in a compliant system will maintain the required performance. Use only shielded cables when connecting peripherals to assure that appropriate radio frequency emissions compliance is maintained.

Operation

Product Damage

High humidity and condensation on the board surface causes short circuits.

Do not operate the board outside the specified environmental limits.

Make sure the board is completely dry and there is no moisture on any surface before applying power.

Damage of Circuits

Electrostatic discharge and incorrect installation and removal can damage circuits or shorten their life.

Before touching the board or electronic components, make sure that you are working in an ESD-safe environment.

Board Malfunction

Switches marked as reserved might carry production-related functions and can cause the board to malfunction if their setting is changed.

Do not change settings of switches marked as reserved. The setting of switches which are not marked as reserved has to be checked and changed before board installation.

Installation

Data Loss

Powering down or removing a board before the operating system or other software running on the board has been properly shut down may cause corruption of data or file systems.

Make sure all software is completely shut down before removing power from the board or removing the board from the chassis.

Product Damage

Only use injector handles for board insertion to avoid damage to the front panel and/or PCB. Deformation of the front panel can cause an electrical short or other board malfunction.

Product Damage

Inserting or removing modules with power applied may result in damage to module components.

Before installing or removing additional devices or modules, read the documentation that came with the product.

Cabling and Connectors

Product Damage

RJ-45 connectors on modules are either twisted-pair Ethernet (TPE) or E1/T1/J1 network interfaces. Connecting an E1/T1/J1 line to an Ethernet connector may damage your system.

- Make sure that TPE connectors near your working area are clearly marked as network connectors.
- Verify that the length of an electric cable connected to a TPE bushing does not exceed 100 meters.
- Make sure the TPE bushing of the system is connected only to safety extra low voltage circuits (SELV circuits).

If in doubt, ask your system administrator.

Environment

Improper disposal of used products may harm the environment. Always dispose of used products according to your country's legislation and manufacturer's instructions.

Safety Notes

Sicherheitshinweise

Dieses Kapitel enthält Hinweise, die potentiell gefährlichen Prozeduren innerhalb dieses Handbuchs vorrangestellt sind. Beachten Sie unbedingt in allen Phasen des Betriebs, der Wartung und der Reparatur des Systems die Anweisungen, die diesen Hinweisen enthalten sind. Sie sollten außerdem alle anderen Vorsichtsmaßnahmen treffen, die für den Betrieb des Produktes innerhalb Ihrer Betriebsumgebung notwendig sind. Wenn Sie diese Vorsichtsmaßnahmen oder Sicherheitshinweise, die an anderer Stelle dieses Handbuchs enthalten sind, nicht beachten, kann das Verletzungen oder Schäden am Produkt zur Folge haben.

Penguin Solutions™ ist darauf bedacht, alle notwendigen Informationen zum Einbau und zum Umgang mit dem Produkt in diesem Handbuch bereit zu stellen. Da es sich jedoch um ein komplexes Produkt mit vielfältigen Einsatzmöglichkeiten handelt, können wir die Vollständigkeit der im Handbuch enthaltenen Informationen nicht garantieren. Falls Sie weitere Informationen benötigen sollten, wenden Sie sich bitte an die für Sie zuständige Geschäftsstelle von Penguin Solutions.

Das Produkt wurde entwickelt, um die Sicherheitsanforderungen für SELV Geräte nach der Norm EN 60950-1 für informationstechnische Einrichtungen zu erfüllen. Die Verwendung des Produkts in einer anderen Anwendung erfordert eine Sicherheitsüberprüfung für diese spezifische Anwendung.

Einbau, Wartung und Betrieb dürfen nur von durch Penguin Solutions ausgebildetem oder im Bereich Elektronik oder Elektrotechnik qualifiziertem Personal durchgeführt werden. Die in diesem Handbuch enthaltenen Informationen dienen ausschließlich dazu, das Wissen von Fachpersonal zu ergänzen, können dieses jedoch nicht ersetzen.

Halten Sie sich von stromführenden Leitungen innerhalb des Produktes fern. Entfernen Sie auf keinen Fall Abdeckungen am Produkt. Nur werksseitig zugelassenes Wartungspersonal oder anderweitig qualifiziertes Wartungspersonal darf Abdeckungen entfernen, um Komponenten zu ersetzen oder andere Anpassungen vorzunehmen.

Installieren Sie keine Ersatzteile oder führen Sie keine unerlaubten Veränderungen am Produkt durch, sonst verfällt die Garantie. Wenden Sie sich für Wartung oder Reparatur bitte an die für Sie zuständige Geschäftsstelle von Penguin Solutions. So stellen Sie sicher, dass alle sicherheitsrelevanten Aspekte beachtet werden.

EMV

Das Produkt wurde in einem Penguin Edge™ Standardsystem getestet. Es erfüllt die für digitale Geräte der Klasse A gültigen Grenzwerte in einem solchen System gemäß den FCC-Richtlinien Abschnitt 15 bzw. EN 55022 Klasse A. Diese Grenzwerte sollen einen angemessenen Schutz vor Störstrahlung beim Betrieb des Produktes in Gewerbe- sowie Industriegebieten gewährleisten.

Sicherheitshinweise

Das Produkt arbeitet im Hochfrequenzbereich und erzeugt Störstrahlung. Bei unsachgemäßem Einbau und anderem als in diesem Handbuch beschriebenen Betrieb können Störungen im Hochfrequenzbereich auftreten.

Wird das Produkt in einem Wohngebiet betrieben, so kann dies mit grosser Wahrscheinlichkeit zu starken Störungen führen, welche dann auf Kosten des Produktanwenders beseitigt werden müssen. Änderungen oder Modifikationen am Produkt, welche ohne ausdrückliche Genehmigung von Penguin Solutions durchgeführt werden, können dazu führen, dass der Anwender die Genehmigung zum Betrieb des Produktes verliert. Boardprodukte werden in einem repräsentativen System getestet, um zu zeigen, dass das Board den oben aufgeführten EMV-Richtlinien entspricht. Eine ordnungsgemässe Installation in einem System, welches die EMV-Richtlinien erfüllt, stellt sicher, dass das Produkt gemäss den EMV-Richtlinien betrieben wird. Verwenden Sie nur abgeschirmte Kabel zum Anschluss von Zusatzmodulen. So ist sichergestellt, dass sich die Aussendung von Hochfrequenzstrahlung im Rahmen der erlaubten Grenzwerte bewegt.

Warnung! Dies ist eine Einrichtung der Klasse A. Diese Einrichtung kann im Wohnbereich Funkstörungen verursachen. In diesem Fall kann vom Betreiber verlangt werden, angemessene Maßnahmen durchzuführen.

Betrieb

Beschädigung des Produktes

Hohe Luftfeuchtigkeit und Kondensat auf der Oberfläche des Produktes können zu Kurzschlüssen führen.

Betreiben Sie das Produkt nur innerhalb der angegebenen Grenzwerte für die relative Luftfeuchtigkeit und Temperatur. Stellen Sie vor dem Einschalten des Stroms sicher, dass sich auf dem Produkt kein Kondensat befindet.

Beschädigung von Schaltkreisen

Elektrostatische Entladung und unsachgemäßer Ein- und Ausbau des Produktes kann Schaltkreise beschädigen oder ihre Lebensdauer verkürzen.

Bevor Sie das Produkt oder elektronische Komponenten berühren, vergewissern Sie sich, daß Sie in einem ESD-geschützten Bereich arbeiten.

Fehlfunktion des Produktes

Schalter, die mit Reserved gekennzeichnet sind, können mit produktionsrelevanten Funktionen belegt sein. Das Ändern dieser Schalter kann im normalen Betrieb Störungen auslösen.

Verstellen Sie nur solche Schalter, die nicht mit Reserved gekennzeichnet sind. Prüfen und ggf. ändern Sie die Einstellungen der nicht mit Reserved gekennzeichneten Schalter, bevor Sie das Produkt installieren.

Installation

Datenverlust

Das Herunterfahren oder die Deinstallation eines Boards bevor das Betriebssystem oder andere auf dem Board laufende Software ordnungsmemäss beendet wurde, kann zu partiellem Datenverlust sowie zu Schäden am Filesystem führen.

Stellen Sie sicher, dass sämtliche Software auf dem Board ordnungsgemäss beendet wurde, bevor Sie das Board herunterfahren oder das Board aus dem Chassis entfernen.

Beschädigung des Produktes

Fehlerhafte Installation des Produktes kann zu einer Beschädigung des Produktes führen.

Verwenden Sie die Handles, um das Produkt zu installieren/deinstallieren. Auf diese Weise vermeiden Sie, dass das Face Plate oder die Platine deformiert oder zerstört wird.

Beschädigung des Produktes und von Zusatzmodulen

Fehlerhafte Installation von Zusatzmodulen, kann zur Beschädigung des Produktes und der Zusatzmodule führen.

Lesen Sie daher vor der Installation von Zusatzmodulen die zugehörige Dokumentation.

Kabel und Stecker

Beschädigung des Produktes

Bei den RJ-45-Steckern, die sich an dem Produkt befinden, handelt es sich entweder um Twisted-Pair-Ethernet (TPE) oder um E1/T1/J1-Stecker. Beachten Sie, dass ein versehentliches Anschließen einer E1/T1/J1-Leitung an einen TPE-Stecker das Produkt zerstören kann.

- Kennzeichnen Sie deshalb TPE-Anschlüsse in der Nähe Ihres Arbeitsplatzes deutlich als Netzwerkanschlüsse.
- Stellen Sie sicher, dass die Länge eines mit Ihrem Produkt verbundenen TPE-Kabels 100 m nicht überschreitet.
- Das Produkt darf über die TPE-Stecker nur mit einem Sicherheits-Kleinspannungs-Stromkreis (SELV) verbunden werden.

Bei Fragen wenden Sie sich an Ihren Systemverwalter.

Sicherheitshinweise

Umweltschutz

Unsachgemäße Entsorgung von gebrauchten Produkten kann die Umwelt schädigen. Entsorgen Sie gebrauchte Produkte stets gemäß der in Ihrem Land gültigen Gesetzgebung und den Empfehlungen des Herstellers.

Introduction

1.1 Overview

The VXS1-RTM1 is a Rear Transition Module (RTM) designed to provide I/O expansion of a VME board through the VME P2 connector and/or the VXS P0 connector. This document describes the features and functions of the RTM and provides the procedure for hardware preparation and installation.

1.2 Features

The following table lists the VXS1-RTM features.

Table 1-1 I/O Features List

Function	Features
I/O	One display port with mini-DP connector to RTM panel Four serial ports to RTM, two on micro-DB9 connectors on RTM panel and two on planar headers Two 10/100/1000BASE-T Ethernet channels to RJ-45 connectors on RTM panel Two USB3.0 ports to RTM with USB type A connectors on RTM panel (one USB3.0 port is muxed with ESATA port) Two ESATA ports to RTM with ESATA connectors on RTM panel (one ESATA port is muxed with USB3.0 port) Four GPIOs to planar headers on RTM

1.3 Standard Compliances

The VXS1-RTM1 is designed to be CE compliant and to meet the following standard requirements.

Table 1-2 Board Standard Compliances

Standard	Description
UL 60950-1 EN 60950-1 IEC 60950-1 CAN/CSA C22.2 No 60950-1	Safety Requirements (legal)

Introduction

Table 1-2 Board Standard Compliances (continued)

Standard	Description
CISPR 22 EN 55022 EN 55024 FCC Class A VCCI Japan AS/NZS CISPR 22	EMC requirements (legal) on system level (predefined Penguin Edge system)
ETSI EN 300 019 series	Environmental Requirements
Directive (EU) 2015/863 (amending Annex II to Directive 2011/65/EU)	Directive on the restriction of the use of certain hazardous substances in electrical and electronic equipment (RoHS)

1.4 Mechanical Data

This table provides details on the board's mechanical data.

Table 1-3 Mechanical Data

Characteristic	Value
Height	233.44 mm
Depth	80 mm
Width	20.32 mm
Weight	230 g

1.5 Ordering and Support Information

Refer to the data sheet for the MVME8100 SBC for a complete list of available variants and accessories. Refer to [Appendix A, Related Documentation](#) or consult your local Penguin Solutions™ sales representative for the availability of other variants.

For technical assistance, documentation, or to report product damage or shortages, contact your local Penguin Solutions sales representative or visit

<https://www.penguinsolutions.com/edge/support/>.

Hardware Preparation and Installation

2.1 Overview

The following table lists the things you need to do before using this board and explains where you can find the information for performing each step. Be sure to read this entire chapter, including all Caution and Warning notes, before you begin.

2.2 Unpacking and Inspecting the RTM

Read all notices and cautions prior to unpacking the product.

Use ESD protection



Damage of Circuits

Electrostatic discharge and incorrect installation and removal can damage circuits or shorten their life.

Before touching the board or electronic components, make sure that you are working in an ESD-safe environment.

Important Information

The RTM is thoroughly inspected before shipment. If any damage occurred during transportation or any items are missing, contact customer service immediately.

Shipment Inspection

To inspect the shipment, perform the following steps:

1. Verify that you have received all items of your shipment.
2. Check for damage and report any damage or differences to customer service.
3. Remove the desiccant bag shipped together with the board and dispose of it according to your country's legislation.

2.3 Requirements

Make sure that the board, when operated in your particular system configuration, meets the requirements specified in the following sections.

Hardware Preparation and Installation

2.3.1 Environmental Requirements

The following table lists the currently available specifications for the environmental characteristics of the VXS1-RTM1. A complete functional description of the VXS1-RTM1 baseboard appears in [Chapter 4, Functional Description](#).



Operating temperatures refer to the temperature of the air circulating around the board and not to the component temperature.

Table 2-1 VXS1-RTM1 Specifications

Characteristics	Value
Cooling Method	Forced Air
Operating temperature	0°C to +55°C
Storage Temperature	-40°C to +85°C
Relative humidity	To 95% RH
Vibration Sine (10min/axis)	2G, 5 to 500Hz
Vibration Random (1hr/axis)	0.002g ² /Hz, 15 to 2000Hz
Shock	20g/11mS



Product Damage

High humidity and condensation on the board surface causes short circuits.

Do not operate the board outside the specified environmental limits.

Make sure the board is completely dry and there is no moisture on any surface before applying power.

2.3.2 Power Requirements

The RTM uses +5V as a primary power source from the RP2 connector and converts to other voltages internally using on board DC-DC converter. The following table shows the power source required.

Table 2-2 Operating Voltages

Voltage	Minimum	Nominal	Maximum
+5.0V	4.875V (-2.5%)	5.0V	5.25V (+5%)

The power requirements for the RTM are as follows:

Table 2-3 Power Requirements

RTM CONFIGURATION	+5.0V	TOTAL POWER
Air Cooled	0.25A typical	1.25W typical

2.4 Installing Rear Transition Module

The RTM does not support hot swap. You should remove power to the rear slot or system before installing the module. Before installing the transition module, you may need to manually configure the switch and install a PMC I/O Module (PIM).



Product Damage

Only use injector handles for board insertion to avoid damage to the front panel and/or PCB. Deformation of the front panel can cause an electrical short or other board malfunction.



Board Malfunction

Switches marked as reserved might carry production-related functions and can cause the board to malfunction if their setting is changed.

Do not change settings of switches marked as reserved. The setting of switches which are not marked as reserved has to be checked and changed before board installation.

Use ESD protection



Damage of Circuits

Electrostatic discharge and incorrect installation and removal can damage circuits or shorten their life.

Before touching the board or electronic components, make sure that you are working in an ESD-safe environment.

Hardware Preparation and Installation

Installation and Removal Procedure

To begin the installation of the RTM in a chassis, proceed as follows:

1. Turn all equipment power OFF and disconnect the power cable from the AC power source.
2. Remove the chassis cover as instructed in the equipment user's manual.
3. Remove the filler panel(s) from the appropriate card slot(s) at the rear of the chassis (if the chassis has a rear card cage).
4. Install the top and bottom edge of the RTM into the rear guides of the chassis.
5. Ensure that the levers of the two injector/ejectors are in the outward position.
6. Slide the RTM into the chassis until resistance is felt.
7. Simultaneously move the injector/ejector levers in an inward direction.
8. Verify that the RTM is properly seated and secure it to the chassis using the two screws located adjacent to the injector/ejector levers.
9. Connect the appropriate cables to the RTM.

To remove the RTM from the chassis, reverse the procedure and press the red locking tabs (IEEE handles only) to extract the board.

Controls, LEDs, and Connectors

3.1 Overview

This chapter summarizes the controls, LEDs, and connectors for the MVME8100 baseboard.

3.2 Front Panel

The following switch, LEDs, and connectors are available on the VXS1-RTM1 front panel. Refer to the following figure for the location of each.

Figure 3-1 Front Panel LEDs, Connectors, Switch

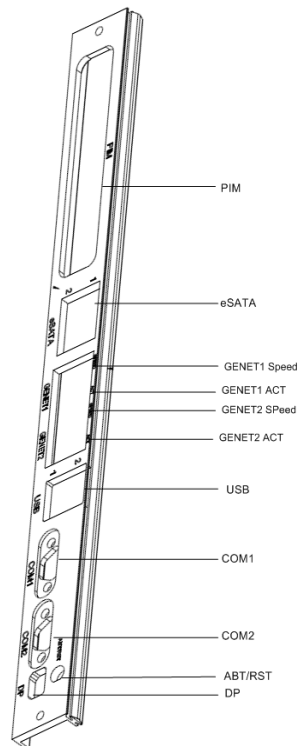

Controls, LEDs, and Connectors

3.2.1 LEDS

3.2.1.1 Front Panel LEDs

Table 3-1 describes the LEDs on the front panel of the RTM. Refer to *Figure 3-1 on page 29* for LED locations.

Table 3-1 Front Panel LEDs

Label	Function	Color	Description
GENET 1 Speed	Gigabit Ethernet 1 Link Speed	OFF	No Link
		Yellow	10/100 BASE-T Operation
		Green	1000 BASE-T Operation
GENET 1 ACT	Gigabit Ethernet 1 Activity	Off	No activity
		Blinking Green	Activity proportional to bandwidth utilization
GENET 2 Speed	Gigabit Ethernet 2 Speed	OFF	No Link
		Yellow	10/100 BASE-T Operation
		Green	1000 BASE-T Operation
GENET 2 ACT	Gigabit Ethernet 2 Activity	Off	No activity
		Blinking Green	Activity proportional to bandwidth utilization

3.2.2 Connectors

This section describes the pin assignments and signals for the connectors on the RTM.

3.2.2.1 Connector Definitions

The following table lists the connectors located on the RTM.

Table 3-2 RTM Connectors

Reference Designator	Function	Pinout Definition	Description
RP0	VXS Backplane RP0	Custom	High speed connector
RP2	VME Backplane RP2	VITA 1	VME / User I/O connector

Table 3-2 RTM Connectors (continued)

Reference Designator	Function	Pinout Definition	Description
P1	Reset		Planar connector for recessed switch on front panel
P2	CPLD Programmer and I2C debug		Ten pins planar header for CPLD programming and I2C debugging
P3	Serial Port		Ten pins planar header connector for Serial Port 3
P4	Serial Port		Ten pins planar header connector for Serial Port 4
P5	GPIO		Eight pins planar header connector for GPIO lines
J1	Mini Display	VESA	VESA mini display connector on front panel
J2	Serial Port	DTE	Mini-DB9 serial port 2 connector on front panel
J3	Serial Port	DTE	Mini-DB9 serial port 1 connector on front panel
J4	USB		Dual stacked USB3.0 connector for USB 1 and 2 on front panel
J5	Dual Ethernet		Dual Ethernet RJ-45 with magnetics connector on front panel
J6	eSATA		Dual stacked eSATA Port 1 and 2 connector on front panel
J10, J14	PIM I/O		I/O connector for PMC rear signals
S1	DIP Switch		Six position switch for EEPROM address selection

3.2.2.2 RTM Connectors

The following sections describe the pin out of headers and connectors used on the RTM.

3.2.2.2.1 VME/VXS RP0 Connector

This high speed connector is defined by VITA41.7 standard. This connector is used to connect high speed signals such as USB3.0, DisplayPort, SATA etc.

Controls, LEDs, and Connectors

The pin assignment is shown in the table below.

Table 3-3 RTM RP0 Connector Pin Assignment

RTM Board RP0	Row G	Row F	Row E		Row D	Row C	Row B		Row A
			Even	Odd			Even	Odd	
Bplane RJ0	Row I	Row H	Row G	Row F	Row E	Row D	Row C	Row B	Row A
1	Void	GND	GND	Void	Void	GND	GND	Void	Void
2	Void	Void	Void	Void	Void	Void	Void	Void	Void
3	Void	Void	Void	Void	Void	Void	Void	Void	Void
4	Void	Void	Void	Void	Void	Void	Void	Void	Void
5	DPC_HPD	GND	GND	SGMII_TX0_N(NC)	SGMII_TX0_P(NC)	GND	GND	SGMII_RX0_N(NC)	SGMII_RX0_P(NC)
6	GND	DPC_D0_N	DPC_D0_P	GND	GND	DPC_D1_N	DPC_D1_P	GND	GND
7	GPIO<0>	GND	GND	DPC_D2_N	DPC_D2_P	GND	GND	DPC_D3_N	DPC_D3_P
8	GND	USB2_SSTX_N	USB2_SSTX_P	GND	GND	USB2_SSRX_N	USB2_SSRX_P	GND	GND
9	GPIO<1>	GND	GND	SATA2_USB1_SSTX_N	SATA2_USB1_SSTX_P	GND	GND	SATA2_USB1_SSRX_N	SATA2_USB1_SSRX_P
10	GND	SATA1_TX_N	SATA1_TX_P	GND	GND	SATA1_RX_N	SATA1_RX_P	GND	GND
11	PEN*(NC)	GND	GND	SGMII_TX1_N(NC)	SGMII_TX1_P(NC)	GND	GND	SGMII_RX1_N(NC)	SGMII_RX1_P(NC)
12	Void	GND	GND	Void	Void	GND	GND	Void	Void
13	Void	Void	Void	Void	Void	Void	Void	Void	Void
14	Void	Void	Void	Void	Void	Void	Void	Void	Void

Table 3-3 RTM RP0 Connector Pin Assignment (continued)

RTM Board RP0	Row G	Row F	Row E		Row D	Row C	Row B		Row A
			Even	Odd			Even	Odd	
Bplane RJ0	Row I	Row H	Row G	Row F	Row E	Row D	Row C	Row B	Row A
15	Void	Void	Void	Void	Void	Void	Void	Void	Void

3.2.2.2.2 VME RP2 Connector

The 32 pins in each row connector is defined by VME standard. This connector is used to connect PMC I/Os, COM ports, USB2.0 and other I/O signals. The pin assignment is shown in the table below:

Table 3-4 RP2 Pin Assignment

1st Row		2nd Row		3rd Row		4th Row		5th Row	
Pin Name	Signal Name	Pin Name	Signal Name	Pin Name	Signal Name	Pin Name	Signal Name	Pin Name	Signal Name
A1	PMC_IO <2>	B1	+5V	C1	PMC_IO <1>	D1	DPC_BP_AUX_P_	Z1	GIGE1_TRD0_P
A2	PMC_IO <4>	B2	GND	C2	PMC_IO <3>	D2	DPC_BP_AUX_N_	Z2	GND
A3	PMC_IO <6>	B3	NC	C3	PMC_IO <5>	D3	GND	Z3	GIGE1_TRD0_N
A4	PMC_IO <8>	B4	NC	C4	PMC_IO <7>	D4	USB1_P	Z4	GND
A5	PMC_IO <10>	B5	NC	C5	PMC_IO <9>	D5	USB1_N	Z5	GIGE1_TRD1_P
A6	PMC_IO <12>	B6	NC	C6	PMC_IO <11>	D6	GND	Z6	GND
A7	PMC_IO <14>	B7	NC	C7	PMC_IO <13>	D7	USB2_DB G_P	Z7	GIGE1_TRD1_N
A8	PMC_IO <16>	B8	NC	C8	PMC_IO <15>	D8	USB2_DB G_N	Z8	GND
A9	PMC_IO <18>	B9	NC	C9	PMC_IO <17>	D9	RTM_SIO	Z9	GIGE1_TRD2_P

Controls, LEDs, and Connectors

Table 3-4 RP2 Pin Assignment (continued)

1st Row		2nd Row		3rd Row		4th Row		5th Row	
Pin Name	Signal Name	Pin Name	Signal Name	Pin Name	Signal Name	Pin Name	Signal Name	Pin Name	Signal Name
A10	PMC_IO <20>	B10	NC	C10	PMC_IO <19>	D10	RTM_RST_L	Z10	GND
A11	PMC_IO <22>	B11	NC	C11	PMC_IO <21>	D11	BP_GPIO2	Z11	GIGE1_TRD2_N
A12	PMC_IO <24>	B12	GND	C12	PMC_IO <23>	D12	BP_GPIO3	Z12	GND
A13	PMC_IO <26>	B13	+5V	C13	PMC_IO <25>	D13	I2C_SDA	Z13	GIGE1_TRD3_P
A14	PMC_IO <28>	B14	NC	C14	PMC_IO <27>	D14	I2C_SCL	Z14	GND
A15	PMC_IO <30>	B15	NC	C15	PMC_IO <29>	D15	COM1_RX_CTS_A_P	Z15	GIGE1_TRD3_N
A16	PMC_IO <32>	B16	NC	C16	PMC_IO <31>	D16	COM1_RX_CTS_A_N	Z16	GND
A17	PMC_IO <34>	B17	NC	C17	PMC_IO <33>	D17	COM2_RX_CTS_A_P	Z17	GIGE2_TRD0_P
A18	PMC_IO <36>	B18	NC	C18	PMC_IO <35>	D18	COM2_RX_CTS_A_N	Z18	GND
A19	PMC_IO <38>	B19	NC	C19	PMC_IO <37>	D19	COM3_RX_CTS_A_P	Z19	GIGE2_TRD0_N
A20	PMC_IO <40>	B20	NC	C20	PMC_IO <39>	D20	COM3_RX_CTS_A_N	Z20	GND
A21	PMC_IO <42>	B21	NC	C21	PMC_IO <41>	D21	COM4_RX_CTS_A_P	Z21	GIGE2_TRD1_P

Controls, LEDs, and Connectors

Table 3-4 RP2 Pin Assignment (continued)

1st Row		2nd Row		3rd Row		4th Row		5th Row	
Pin Name	Signal Name	Pin Name	Signal Name	Pin Name	Signal Name	Pin Name	Signal Name	Pin Name	Signal Name
A22	PMC_IO <44>	B22	GND	C22	PMC_IO <43>	D22	COM4_RX _CTS_A_ N	Z22	GND
A23	PMC_IO <46>	B23	NC	C23	PMC_IO <45>	D23	COM1_TX _RTS_A_ P	Z23	GIGE2_ TRD1_N
A24	PMC_IO <48>	B24	NC	C24	PMC_IO <47>	D24	COM1_TX _RTS_A_ N	Z24	GND
A25	PMC_IO <50>	B25	NC	C25	PMC_IO <49>	D25	COM2_TX _RTS_A_ P	Z25	GIGE2_ TRD2_P
A26	PMC_IO <52>	B26	NC	C26	PMC_IO <51>	D26	COM2_TX _RTS_A_ N	Z26	GND
A27	PMC_IO <54>	B27	NC	C27	PMC_IO <53>	D27	COM3_TX _RTS_A_ P	Z27	GIGE2_ TRD2_N
A28	PMC_IO <56>	B28	NC	C28	PMC_IO <55>	D28	COM3_TX _RTS_A_ N	Z28	GND
A29	PMC_IO <58>	B29	NC	C29	PMC_IO <57>	D29	COM4_TX _RTS_A_ P	Z29	GIGE2_ TRD3_P
A30	PMC_IO <60>	B30	NC	C30	PMC_IO <59>	D30	COM4_TX _RTS_A_ N	Z30	GND
A31	PMC_IO <62>	B31	GND	C31	PMC_IO <61>	D31	GND	Z31	GIGE2_ TRD3_N
A32	PMC_IO <64>	B32	+5V	C32	PMC_IO <63>	D32	+5V	Z32	GND

Controls, LEDs, and Connectors

3.2.2.2.3 RTM Mini Display Connector J1

The RTM provides one mini display connector on its front panel for connecting display port capable display devices to display port capable front blades. The pin assignment for this connector is as follows:

Table 3-5 RTM Mini Display Port Connector (J1)

Pin Name	Signal Name
1	GND
2	HPD_IN
3	ML_LANE0_P
4	CAD_IN
5	ML_LANE0_N
6	10M ohm to GND
7	GND
8	GND
9	ML_LANE1_P
10	ML_LANE3_P
11	ML_LANE1_N
12	ML_LANE3_N
13	GND
14	GND
15	ML_LANE2_P
16	DPC_AUX_P
17	ML_LANE2_N
18	DPC_AUX_N
19	GND
20	+3V3

3.2.2.2.4 RTM Serial Port 1 Connector J3

The RTM provides one standard mini-9 serial port connector on its front panel. The pin assignment for this connector is as follows:

Table 3-6 RTM COM 1 Connector (J3)

Pin Name	Signal Name
1	NC
2	COM1_RX_CTS_P
3	COM1_TX_RTS_P
4	NC
5	GND
6	NC
7	COM1_TX_RTS_N
8	COM1_RX_CTS_N
9	NC

3.2.2.2.5 RTM Serial Port 2 Connector J2

The RTM provides one standard mini-9 serial port connector on its front panel. The pin assignment for this connector is as follows:

Table 3-7 RTM COM 2 Connector (J2)

Pin Name	Signal Name
1	NC
2	COM2_RX_CTS_P
3	COM2_TX_RTS_P
4	NC
5	GND
6	NC
7	COM2_TX_RTS_N
8	COM2_RX_CTS_N
9	NC

Controls, LEDs, and Connectors

3.2.2.2.6 RTM Serial Port 3 Connector P3

The RTM provides one planar header for COM port 3. The pin assignment for this connector is as follows:

Table 3-8 RTM COM 3 Header (P3)

Pin Name	Signal Name
1	NC
2	COM3_RX_CTS_P
3	COM3_TX_RTS_P
4	NC
5	GND
6	NC
7	COM3_TX_RTS_N
8	COM3_RX_CTS_N
9	NC
10	NC

3.2.2.2.7 RTM Serial Port 4 Connector P4

The RTM provides one planar header for COM port 4. The pin assignment for this connector is as follows:

Table 3-9 RTM COM 4 Header (P4)

Pin Name	Signal Name
1	NC
2	COM4_RX_CTS_P
3	COM4_TX_RTS_P
4	NC
5	GND
6	NC
7	COM4_TX_RTS_N
8	COM4_RX_CTS_N
9	NC

Table 3-9 RTM COM 4 Header (P4) (continued)

Pin Name	Signal Name
10	NC

3.2.2.2.8 RTM USB 1 and USB 2 Connector J4

The RTM provides one standard dual stacked USB port 1 and 2 type A connector on its front panel. Both ports provide USB 3.0 capability and backward compatible with USB 2.0. The pin assignment for this connector is as follows:

Table 3-10 RTM Dual USB 1 and 2 Connector (J4)

Pin Name	Signal Name
1	USB1_+5V
2	USB1_N
3	USB1_P
4	GND
5	USB1_SSRX_N
6	USB1_SSRX_P
7	GND
8	USB1_SSTX_N
9	USB1_SSTX_P
10	USB2_+5V
11	USB2_N
12	USB2_P
13	GND
14	USB2_SSRX_N
15	USB2_SSRX_P
16	GND
17	USB2_SSTX_N
18	USB2_SSTX_P

Controls, LEDs, and Connectors

3.2.2.2.9 RTM Dual Ethernet Connector J5

The RTM provides one dual ethernet connector on its front panel for connecting 1000BASE-T Ethernet. The pin assignment for this connector is as follows:

Table 3-11 RTM Dual Ethernet Connector (J5)

Pin Name	Signal Name	Pin Name	Signal Name
1A	GND_PE	1B	GND_PE
2A	NC	2B	NC
3A	GIGE1_TRD3_P	3B	GIGE2_TRD3_P
4A	GIGE1_TRD3_N	4B	GIGE2_TRD3_N
5A	GIGE1_TRD2_P	5B	GIGE2_TRD2_P
6A	GIGE1_TRD2_N	6B	GIGE2_TRD2_N
7A	GIGE1_TRD1_P	7B	GIGE2_TRD1_P
8A	GIGE1_TRD1_N	8B	GIGE2_TRD1_N
9A	GIGE1_TRD0_P	9B	GIGE2_TRD0_P
10A	GIGE1_TRD0_N	10B	GIGE2_TRD0_N
D1A	GIGE1_LINK1_L	D1B	GIGE2_LINK1_L
D2A	GIGE1_LINK2_L	D2B	GIGE2_LINK2_L
D3A	GIGE1_LED1_PWR	D3B	GIGE2_LED1_PWR
D4A	GIGE1_ACT_L	D4B	GIGE2_ACT_L

3.2.2.2.10 RTM eSATA Port 1 and 2 Connector J6

The RTM provides one dual stacked eSATA connector on its front panel. The pin assignment for this connector is as follows:

Table 3-12 Dual eSATA Connector (J6)

Pin Name	Signal Name
A1	GND
A2	ESATA1_TX_P
A3	ESATA1_TX_N
A4	GND
A5	ESATA1_RX_N

Table 3-12 Dual eSATA Connector (J6) (continued)

Pin Name	Signal Name
A6	ESATA1_RX_P
A7	GND
B1	GND
B2	ESATA2_TX_P
B3	ESATA2_TX_N
B4	GND
B5	ESATA2_RX_N
B6	ESATA2_RX_P
B7	GND

3.2.2.2.11 RTM PIM Connector J10

The RTM provides two PMC connectors J10 and J14 for PMC rear I/Os signals. These connectors are used to install PIM module. The pin assignment of J10 connector is shown below. The pin assignment of J14 is shown in [Table 3-14](#).

Table 3-13 PIM Connector (J10)

Pin Name	Signal Name	Pin Name	Signal Name
1	NC	33	NC
2	NC	34	GND
3	NC	35	NC
4	NC	36	NC
5	+5V_RTM	37	+5V_RTM
6	NC	38	NC
7	NC	39	NC
8	NC	40	NC
9	NC	41	NC
10	+3V3_RTM	42	+3V3_RTM
11	NC	43	NC

Controls, LEDs, and Connectors

Table 3-13 PIM Connector (J10) (continued)

Pin Name	Signal Name	Pin Name	Signal Name
12	NC	44	NC
13	GND	45	GND
14	NC	46	NC
15	NC	47	NC
16	NC	48	NC
17	NC	49	NC
18	GND	50	GND
19	NC	51	NC
20	NC	52	NC
21	+5V_RTM	53	+5V_RTM
22	NC	54	NC
23	NC	55	NC
24	NC	56	NC
25	NC	57	NC
26	+3V3_RTM	58	+3V3_RTM
27	NC	59	NC
28	NC	60	NC
29	GND	61	NC
30	NC	62	NC
31	NC	63	NC
32	NC	64	NC

3.2.2.2.12 RTM PIM Connector J14

The RTM provides two PMC connectors J10 and J14 for PMC rear I/Os signals. These connectors are used to install the PIM module. The pin assignment of J14 connector is shown below.

Table 3-14 PIM Connector (J14)

Pin Name	Signal Name	Pin Name	Signal Name
1	PMC_IO<1>	33	PMC_IO<33>
2	PMC_IO<2>	34	PMC_IO<34>
3	PMC_IO<3>	35	PMC_IO<35>
4	PMC_IO<4>	36	PMC_IO<36>
5	PMC_IO<5>	37	PMC_IO<37>
6	PMC_IO<6>	38	PMC_IO<38>
7	PMC_IO<7>	39	PMC_IO<39>
8	PMC_IO<8>	40	PMC_IO<40>
9	PMC_IO<9>	41	PMC_IO<41>
10	PMC_IO<10>	42	PMC_IO<42>
11	PMC_IO<11>	43	PMC_IO<43>
12	PMC_IO<12>	44	PMC_IO<44>
13	PMC_IO<13>	45	PMC_IO<45>
14	PMC_IO<14>	46	PMC_IO<46>
15	PMC_IO<15>	47	PMC_IO<47>
16	PMC_IO<16>	48	PMC_IO<48>
17	PMC_IO<17>	49	PMC_IO<49>
18	PMC_IO<18>	50	PMC_IO<50>
19	PMC_IO<19>	51	PMC_IO<51>
20	PMC_IO<20>	52	PMC_IO<52>
21	PMC_IO<21>	53	PMC_IO<53>
22	PMC_IO<22>	54	PMC_IO<54>
23	PMC_IO<23>	55	PMC_IO<55>

Controls, LEDs, and Connectors

Table 3-14 PIM Connector (J14) (continued)

Pin Name	Signal Name	Pin Name	Signal Name
24	PMC_IO<24>	56	PMC_IO<56>
25	PMC_IO<25>	57	PMC_IO<57>
26	PMC_IO<26>	58	PMC_IO<58>
27	PMC_IO<27>	59	PMC_IO<59>
28	PMC_IO<28>	60	PMC_IO<60>
29	PMC_IO<29>	61	PMC_IO<61>
30	PMC_IO<30>	62	PMC_IO<62>
31	PMC_IO<31>	63	PMC_IO<63>
32	PMC_IO<32>	64	PMC_IO<64>

3.2.2.2.13 RTM Reset Connector P1

The RTM provides one 2-pin planar header to connect reset switch on its front panel. The pin assignment for this connector is as follows:

Table 3-15 RTM Reset Switch Connector (P1)

PIN#	SIGNAL
1	RTM_RST#
2	GND

3.2.2.2.14 RTM CPLD Programming and Debug Connector P2

The RTM provides one 10-pin planar header to connect JTAG signals to program CPLD. The connector also provides access to I2C bus for debugging. The pin assignment of this connector is as follows:

Table 3-16 RTM CPLD Programming & Debug Header (P2)

Pin Name	Signal Name
1	+3V3
2	TMS
3	NC
4	TCK
5	NC

Table 3-16 RTM CPLD Programming & Debug Header (P2) (continued)

Pin Name	Signal Name
6	TDI
7	I2C_SCL
8	TDO
9	I2C_SDA
10	GND

3.2.2.2.15 RTM GPIO Connector P5

The RTM provides one 8-pin planar header connector for GPIO signals. The pin assignment of this connector is as follows:

Table 3-17 GPIO Header (P5)

Pin Name	Signal Name
1	GPIO0
2	GND
3	GPIO1
4	GND
5	GPIO2
6	GND
7	GPIO3
8	GND

3.2.3 Switches

One 6-position switch is provided for RTM. The default setting on all switch positions is OFF.

Controls, LEDs, and Connectors

3.2.3.1 RTM Configuration Switch

Pin assignment of RTM switch S1 is shown below:

Table 3-18 RTM Configuration Switch (S1)

Pin Name	Signal Name	ON	OFF
SW6	SW2_CPLD	Reserved	
SW5	SW1_CPLD	Reserved	
SW4	I2C_WP	Write protect RTM VPD EEPROM	Allow to write RM VPD EEPROM
SW3	I2C_ADDR0	RTM VPD EEPROM Address A0, ON=0, OFF=1	
SW2	I2C_ADDR1	RTM VPD EEPROM Address A1, ON=0, OFF=1	
SW1	I2C_ADDR2	RTM VPD EEPROM Address A2, ON=0, OFF=1	

3.2.3.2 RTM FRU EEPROM

The RTM provides a 2Kb serial EEPROM containing FRU configuration information specific to the RTM. Typical information that may be present in the EEPROM include: manufacturer, board revision, build version, date of assembly etc. The RTM FRU EEPROM device address is user selectable through the switch with the default address of 0x57. Refer to the EEPROM data sheet for additional details and/or programming information.

Functional Description

4.1 Overview

The RTM provides rear panel access to four serial ports, two 10/100/1000 Ethernet ports with RJ-45 connectors, two USB3.0 with dual stacked type A connectors (one of USB3.0 port is multiplexed with eSATA port), one display port with mini-DP connector, two eSATA ports, and one PIM slot with front I/O.

4.2 Block Diagram

The next figure shows the block diagram of RTM.

Figure 4-1 Block Diagram

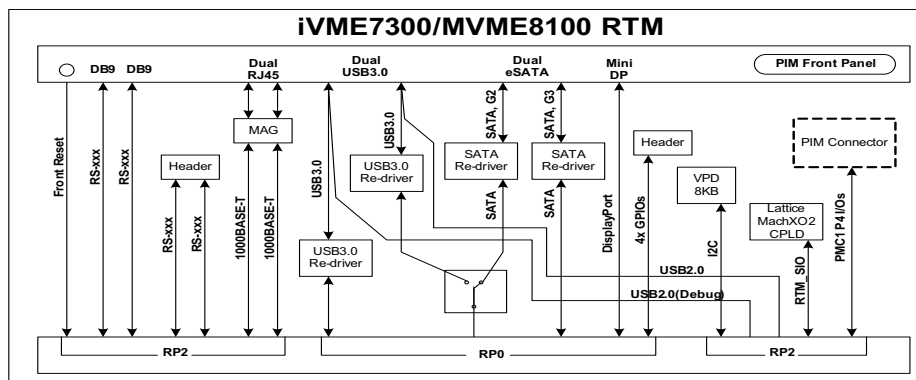

4.3 Ethernet Interfaces

The Ethernets are 10/100/1000 BASE-T based, Gigabit Ethernet and are routed to the RTM panel on RJ-45 connector with integrated magnetics and LED.

4.4 Serial COM Ports

Two of the COM ports routed to RTM are provided on micro-DB9 connectors at RTM panel, while the remaining two RTM COM ports are provided on planar headers.

4.5 USB Interface

USB3.0 ports 1 and 2 are routed to RTM through the RP2 and RP0 connectors. Both ports can operate simultaneously in USB 2.0 mode using signal routed through RP2.

- Port 2 has dedicated USB 3.0 signal connections to RP0 so Port 2 is a dedicated USB 3.0 port
- Port 1 has USB 3.0 signals which are shared with the SATA 2 port and controlled by an on board mux.

An RTM can support two USB3.0 or two eSATA or one USB3.0 and one eSATA combinations on multiplexed lines, as per the user requirement. The selection is controlled by a select signal contained in a serial IO bit stream from the front blade. When USB3.0 ports are not supported on the front blade, the corresponding USB2.0 ports are still supported and can be used on the RTM.

4.6 Display Interface

A display port is configured as DisplayPort or DVI and can be routed to RTM through backplane connector P0. A level shifter is provided on RTM to support either DisplayPort or DVI signaling levels.

4.7 SATA Interface

Port 1 and 2 are routed to RTM through backplane P0 connector where they are available on eSATA connectors on face plate. Port 2 is also multiplexed with Port1 USB3.0 lines. An RTM can support two USB3.0 or two eSATA or one USB3.0, and one eSATA combinations on multiplexed lines, as per the user requirement. The selection is controlled by a select signal contained in a serial IO bit stream from the front blade.

4.8 GPIO Interface

The RTM provides 4 GPIO signals from the front board FPGA. All 4 GPIO signals are routed to RTM through backplane connector P0 and P2.

4.9 Power Supply Sources

All RTM power is supplied from the VME +5V supply through the RP2 connector. The RTM has an on-board +3.3V power supply derived from +5V.

Related Documentation

A.1 Penguin Solutions Documentation

Technical documentation can be found by using the Documentation Search at <https://www.penguinsolutions.com/edge/support/> or you can obtain electronic copies of documentation by contacting your local sales representative

Table A-1 Penguin Edge Documentation

Document Title	Document Number
MVME8100 Programmer's Reference	6806800P28
MVME8100 Installation and Use	6806800P25

A.2 Related Specifications

For additional information, refer to the following table for related specifications. As an additional help, a source for the listed document is provided. Please note that, while these sources have been verified, the information is subject to change without notice.

Table A-2 Related Specifications

Organization and Standard	Document Title
VITA Standards Organization	
VME64	ANSI/VITA 1-1994
Processor PMC	ANSI/VITA 32-2003
XMC Switched Mezzanine Card Auxiliary Standard, September 2005	VITA 42.0-2005
Conduction Cooled PMC	ANSI/VITA 20 - 2001
PMC I/O Module (PIM) Draft Standard	VITA 36 Draft Rev 0.1 July 19, 1999
Universal Serial Bus	
Universal Serial Bus Specification	Revision 2.0 April 27, 2000
Institute for Electrical and Electronics Engineers, Inc.	
IEEE Standard for a Common Mezzanine Card Family: CMC	IEEE1386 Oct 25, 2001

Related Documentation

Table A-2 Related Specifications (continued)

Organization and Standard	Document Title
IEEE Standard Physical and Environmental Layer for PCI Mezzanine Cards: PMC	IEEE1386.1 Oct 25, 2001
Additional Mechanical Specifications	IEEE 1101.10 - 1996
IEEE Standard for Mechanical Core Specifications for Microcomputers	IEEE 1101.1 - 1998

A.3 Manufacturers' Documents

For additional information, refer to the following table for manufacturers' data sheets or user's manuals. As an additional help, a source for the listed document is provided. Please note that, while these sources have been verified, the information is subject to change without notice.

Table A-3 Manufacturer's Publications

Document Title and Source	Publication Number
NXP	
P5020/P5010 QorIQ Integrated Processor Hardware Specifications	P5020EC
P5020 QorIQ Integrated Multicore Communication Processor Reference Manual	P5020RM



Penguin Solutions is a trade name used by SMART Embedded Computing, Inc., a wholly owned subsidiary of SMART Global Holdings, Inc. Penguin Edge is a trademark owned by Penguin Computing, Inc., a wholly owned subsidiary of SMART Global Holdings, Inc. NXP and QorIQ are trademarks of NXP B.V. All other logos, trade names, and trademarks are the property of their respective owners. ©2022 SMART Embedded Computing, Inc.