



---

## **Penguin Edge™ AXP1440 Shelf**

Installation and Use

P/N: 6806800H23X

July 2022

---



## Legal Disclaimer\*

SMART Embedded Computing, Inc. (SMART EC), dba Penguin Solutions™, assumes no responsibility for errors or omissions in these materials. **These materials are provided "AS IS" without warranty of any kind, either expressed or implied, including but not limited to, the implied warranties of merchantability, fitness for a particular purpose, or non-infringement.** SMART EC further does not warrant the accuracy or completeness of the information, text, graphics, links, or other items contained within these materials. SMART EC shall not be liable for any special, indirect, incidental, or consequential damages, including without limitation, lost revenues or lost profits, which may result from the use of these materials. SMART EC may make changes to these materials, or to the products described therein, at any time without notice. SMART EC makes no commitment to update the information contained within these materials.

Electronic versions of this material may be read online, downloaded for personal use, or referenced in another document as a URL to a SMART EC website. The text itself may not be published commercially in print or electronic form, edited, translated, or otherwise altered without the permission of SMART EC.

It is possible that this publication may contain reference to or information about SMART EC products, programming, or services that are not available in your country. Such references or information must not be construed to mean that SMART EC intends to announce such SMART EC products, programming, or services in your country.

## Limited and Restricted Rights Legend

If the documentation contained herein is supplied, directly or indirectly, to the U.S. Government, the following notice shall apply unless otherwise agreed to in writing by SMART EC.

Use, duplication, or disclosure by the Government is subject to restrictions as set forth in subparagraph (b)(3) of the Rights in Technical Data clause at DFARS 252.227-7013 (Nov. 1995) and of the Rights in Noncommercial Computer Software and Documentation clause at DFARS 252.227-7014 (Jun. 1995).

### **SMART Embedded Computing, Inc., dba Penguin Solutions**

2900 S. Diablo Way, Suite 190

Tempe, Arizona 85282

USA

\*For full legal terms and conditions, visit <https://www.penguinsolutions.com/edge/legal/>

# Table of Contents

---

About this Manual .....	13
Safety Notes .....	19
Sicherheitshinweise .....	29
<b>1 Platform Architecture .....</b>	<b>41</b>
1.1 Description .....	41
1.2 PICMG Compliance .....	41
1.3 Shelf Topology .....	42
1.4 Network Descriptions .....	42
1.4.1 Base Interface .....	42
1.4.2 Fabric Interface .....	43
1.4.3 IPMI Network .....	43
1.4.4 Update Channel Interface .....	44
1.5 Backplane and Component Connectivity .....	44
1.6 Operating Systems .....	45
1.7 Remote Management and Maintenance .....	46
<b>2 AXP1440 Shelf Description .....</b>	<b>47</b>
2.1 Overview .....	47
2.2 Platform Features .....	47
2.3 Enclosure .....	50
2.4 Power Consumption .....	50
2.5 Shelf Ground Configuration .....	50
2.6 Backplane .....	51
2.6.1 Functional Layout .....	51
2.6.2 E-Keying .....	52
2.6.3 Shelf FRU Information .....	53
2.6.4 Backplane Slot Connectors .....	53
2.6.5 Zone Locations on a Blade .....	55
2.7 IEEE802.3ap/IEEE802.3ba .....	56
2.8 Fan Tray Modules (FTMs) .....	57
2.9 Power Entry Modules (PEMs) .....	58
2.10 Stationary Boards .....	59

# Table of Contents

---

2.11	Standard Compliances	60
2.12	WEEE Compliance	61
<b>3</b>	<b>Site Preparation</b>	<b>63</b>
3.1	Overview	63
3.2	Site Planning Considerations	63
3.2.1	Receiving and Unpacking the System	63
3.2.2	Site and Installation Planning	64
3.2.3	Requirements	65
3.2.3.1	Environmental Requirements	65
3.2.3.2	Power Requirements	67
3.2.4	Dimensions and Weight	68
3.2.5	Mounting Options	68
3.2.6	Grounding	69
3.2.7	Rack Mount Dimensions	69
3.2.8	Airflow Requirements	70
3.2.9	Acoustic Noise Control	71
3.3	Site Planning Checklists	72
<b>4</b>	<b>AXP1440 Operations</b>	<b>75</b>
4.1	Overview	75
4.2	Recommended Power-On Procedures	75
4.3	Recommended Power-Off Procedures	75
4.4	Emergency Power-Off Procedures	76
4.5	Power Entry Module (PEM)	76
4.5.1	Description	76
4.5.2	IPMC Circuitry	77
4.6	Fan Tray Modules	78
4.6.1	Description	78
4.6.2	Cooling Budget	78
4.6.3	IPMC Circuitry	79
4.7	Air Filter Maintenance	79
4.8	Cleaning the Air Filter	80
4.8.1	Storing the Filter	80

- 5 AXP1440 Shelf Installation . . . . . 83**
  - 5.1 Overview . . . . . 83
  - 5.2 Shelf Physical Characteristics . . . . . 83
  - 5.3 Installation Prerequisites . . . . . 84
    - 5.3.1 Equipment You Will Need . . . . . 84
    - 5.3.2 Rack/Cabinet Cooling Guidelines . . . . . 84
    - 5.3.3 Mounting Options and Stabilization . . . . . 86
    - 5.3.4 Weight Distribution Within a Rack . . . . . 87
    - 5.3.5 Electrostatic Discharge (ESD) and Safety Procedures . . . . . 87
  - 5.4 Installing the Shelf . . . . . 87
    - 5.4.1 23" EIA Rack/Cabinet. . . . . 88
    - 5.4.2 600mm ETSI Rack/Cabinet . . . . . 88
  - 5.5 Grounding the Shelf . . . . . 89
  - 5.6 Shelf Ground Configuration . . . . . 89
  - 5.7 DC Power Cable . . . . . 90
  - 5.8 Power Cable Termination . . . . . 91
  - 5.9 Connecting the Cables to the PEM . . . . . 92
  - 5.10 Powering Up the System . . . . . 93
  - 5.11 Accessing the System . . . . . 93
  - 5.12 Upgrading Firmware . . . . . 94
    - 5.12.1 FTM IPMC Firmware Upgrade . . . . . 94
      - 5.12.1.1 FTM Upgrade Sample Output . . . . . 94
    - 5.12.2 PEM IPMC Firmware Upgrade. . . . . 96
      - 5.12.2.1 PEM Upgrade Sample Output . . . . . 96
    - 5.12.3 Shelf Manager Firmware Upgrade. . . . . 97
      - 5.12.3.1 Establishing Network Connectivity to the SAM . . . . . 98
      - 5.12.3.2 Update ShM Firmware on the SAM . . . . . 99
  
- 6 FRU Installation . . . . . 101**
  - 6.1 Overview . . . . . 101
  - 6.2 Installing RTMs, Blades and SAMs . . . . . 101
    - 6.2.1 Module Installation and Removal. . . . . 101
      - 6.2.1.1 Installing the RTM . . . . . 101
      - 6.2.1.2 Removing the RTM . . . . . 105
    - 6.2.2 Node Blade Installation and Removal . . . . . 106
      - 6.2.2.1 Installing the Node Blade . . . . . 106
      - 6.2.2.2 Removing the Node Blade . . . . . 108

# Table of Contents

---

6.2.3	Installing and Removing the Shelf Management Alarm Module . . . . .	109
6.2.3.1	Non-powered System . . . . .	109
6.2.3.2	Powered System . . . . .	110
6.3	Unused Slots . . . . .	111
6.4	Installing Power Entry Modules . . . . .	111
6.4.1	Tools You Will Need . . . . .	112
6.4.2	Replacing the PEM . . . . .	112
6.5	Upper and Lower Fan Tray Modules . . . . .	114
6.5.1	Removing the Upper FTM . . . . .	115
6.5.2	Installing the Upper FTM . . . . .	115
6.5.3	Removing the Lower FTM . . . . .	116
6.5.4	Installing the Lower FTM . . . . .	116
6.6	Replacing the Fan Filter . . . . .	117
<b>7</b>	<b>Shelf Management Alarm Module . . . . .</b>	<b>119</b>
7.1	Overview . . . . .	119
7.2	Features . . . . .	120
7.3	SAM Diagram and Face Plate Layout . . . . .	121
7.4	Functional Description . . . . .	122
7.4.1	IPMB Connectivity . . . . .	123
7.4.2	RS-232 Serial Interface . . . . .	123
7.4.3	Master-Only I2C Bus . . . . .	124
7.4.4	Shelf FRU EEPROM . . . . .	124
7.4.5	SAM LEDs . . . . .	124
7.4.5.1	Hot Swap LED . . . . .	125
7.4.5.2	SAM/ADP Status LEDs . . . . .	125
7.5	Management and Control . . . . .	126
7.5.1	Hardware Monitoring and Control . . . . .	126
7.5.1.1	Voltage Sensors . . . . .	126
7.5.1.2	Temperature Monitoring . . . . .	126
7.5.1.3	Fan Speed and Control . . . . .	126
7.5.2	Redundancy Control . . . . .	129
7.5.2.1	Hardware Redundancy Interface . . . . .	130
7.5.2.2	HRI Protocol . . . . .	131
7.5.2.3	Ethernet Signals . . . . .	131
7.5.2.4	Configuring Front Panel Network Interface . . . . .	133
7.5.2.5	Configuring RMCP Network Interface . . . . .	133
7.5.3	Switchover Signals . . . . .	134

**Table of Contents**

---

- 7.6 Telco Alarm Functionality ..... 135
  - 7.6.1 Telco Alarm Cutoff Push Button..... 135
  - 7.6.2 Telco Alarm LEDs ..... 135
  - 7.6.3 Telco Alarm Interface..... 135
- 7.7 Hot Swap Interface ..... 136
- 7.8 Power ..... 136
- 7.9 SAM Software ..... 136
  - 7.9.1 imls Utility ..... 137

**Related Documentation ..... 139**

- A.1 Penguin Solutions Documentation ..... 139
- A.2 Related Specifications ..... 139

## Table of Contents

---



# List of Figures

---

Figure 1-1	Update Channel	44
Figure 1-2	Location of Zones 1, 2, and 3	45
Figure 2-1	Front Shelf View	48
Figure 2-2	Rear Shelf View	49
Figure 2-3	Backplane Power Segments	52
Figure 2-4	Base and Fabric Interface Connectivity	56
Figure 2-5	Lower Fan Tray Module, Front View	57
Figure 2-6	Upper Front FTM, Front View	57
Figure 2-7	PEM Backplane Connectivity	58
Figure 2-8	PEM View with Detail	59
Figure 3-1	Rack Mounting Dimensions	70
Figure 3-2	Shelf Airflow	71
Figure 3-3	Planning Checklist 1	72
Figure 3-4	Planning Checklist 2	73
Figure 5-1	Rack Mounting Dimensions	85
Figure 5-2	Shelf Airflow Diagram	86
Figure 5-3	Placement of Grounding Lug	89
Figure 5-4	DC Power Connection Detail	91
Figure 6-1	SAM-1500R	109
Figure 6-2	Upper Rear FTM Ejector Handles and LEDs	115
Figure 6-3	Lower Front FTM Ejector Handles and LEDs	116
Figure 7-1	Block Diagram of SAM	121
Figure 7-2	SAM Face Plate	122
Figure 7-3	SAM HRI Interconnection	131
Figure 7-4	Interhub Slot and Shelf Manager Connectivity	132

## List of Figures

---

# List of Tables

---

Table 2-1	DC Shelf Power	50
Table 2-2	Slot Connector Description	53
Table 2-3	Backplane Connectors	53
Table 2-4	Slot Hardware Addressing for J10	54
Table 2-5	Fan Tray Module Hardware Addressing	55
Table 2-6	SAM and PEM Hardware Addressing	55
Table 2-7	FTM LED Status Indicators	57
Table 2-8	PEM LED Status Indicators	59
Table 2-9	ADP LED Status Indicators	60
Table 2-10	Standard Compliances	60
Table 3-1	Environmental Conditions	65
Table 3-2	Critical Temperature Limits	67
Table 3-3	System Power Requirements	67
Table 3-4	Dimensions and Weight of System and Components	68
Table 4-1	PEM IPMB Addresses	77
Table 4-2	Cooling Budget	79
Table 5-1	AXP1440 14-Slot Shelf Physical Characteristics	83
Table 7-1	RJ-45 Serial Port Connector	123
Table 7-2	Alarm Display Panel (ADP) Serial Port Connector	123
Table 7-3	SAM LEDs	124
Table 7-4	Hot Swap LED States	125
Table 7-5	SAM LED Status Indicators	125
Table 7-6	ADP LED Status Indicators	125
Table 7-7	Cooling Budget	128
Table 7-8	Shelf Manager Static Network IP Interfaces	133
Table 7-9	Shelf Manager Dynamic Network IP Interfaces	133
Table 7-10	Hot Swap Interface Pin Out	135
Table A-1	Penguin Solutions Documentation	139
Table A-2	Related Specifications	139

## List of Tables

---

# About this Manual

---

## Overview of Contents

This Installation and Use manual is organized as follows:

- [About this Manual on page 13](#) lists all conventions and abbreviations used in this manual and outlines the revision history.
- [Safety Notes on page 19](#) describes the safety information that must be regarded.
- [Sicherheitshinweise on page 29](#) translation of English Safety Notes to German.
- [Chapter 1, Platform Architecture on page 41](#) describes the system architecture.
- [Chapter 2, AXP1440 Shelf Description on page 47](#) provides an overview of the features of the system and lists the standard compliances.
- [Chapter 3, Site Preparation on page 63](#) provides site planning considerations and checklists, describes the requirements and conditions.
- [Chapter 4, AXP1440 Operations on page 75](#) describes basic operating procedures.
- [Chapter 5, AXP1440 Shelf Installation on page 83](#) describes mounting and installation options.
- [Chapter 6, FRU Installation on page 101](#) describes how to install and replace blades, modules, power components, fans, and air filter.
- [Chapter 7, Shelf Management Alarm Module on page 119](#) describes the shelf management alarm module.
- [Appendix A, Related Documentation on page 139](#) lists related documentation and specifications.

## Abbreviations

This document uses the following abbreviations:

Abbreviation	Definition
10GBASE-BX4	The common name of the standard that defines 10 gigabit-per-second Ethernet data link over eight pairs of copper: Four pairs for transmit and four pairs for received.
AdvancedTCA	Advanced Telecom Computing Architecture
AMC	AdvancedTCA Mezzanine Card
ANSI	American National Standards Institute
ARP	Address Resolution Protocol

## About this Manual

---

<b>Abbreviation</b>	<b>Definition</b>
ARTM	AdvancedTCA Rear Transition Module
ATCA	Advanced Telecommunications Computing Architecture
AWG	American Wire Gauge
BBS	Basic Blade Services
CISPR	Comité International Spécial des Perturbations Radioélectriques
EMC	Electromagnetic Compatibility
EMI	Electromagnetic Interference
EMV	Elektromagnetische Verträglichkeit
EN	European Norm
ESD	Electrostatic Discharge
ETSI	European Telecommunication Standards Institute
FCC	Federal Communications Commission
FRU	Field Replaceable Unit
GmbH	Gesellschaft mit beschränkter Haftung
HA	High Availability
HPI	Hardware Platform Interface
HS	Hot Swap
ID	Identifier
IEC	International Electric Code
IEEE	Institute of Electrical and Electronics Engineers
IPM	Intelligent Platform Management
IPMB	Intelligent Platform Management Bus
IPMC	Intelligent Platform Management Controller
IPMI	Intelligent Platform Management Interface
MMC	Mezzanine Management Controller
NEBS	Network Equipment Building System
NEC	National Electric Code
OEM	Original Equipment Manufacturer
PCI	Peripheral Component Interconnect
PEM	Power Entry Module







Abbreviation	Definition
PICMG	PCI Industrial Computer Manufacturers Group
PMC	PCI Mezzanine Card
RMCP	Remote Management Control Protocol
RoHS	Restriction of Certain Hazardous Substances
RTM	Rear Transition Module
SELV	Safety Extra Low Voltage
ShM	Shelf Manager
ShMC	Shelf Management Controller
SNMP	Simple Network Management Protocol
TNV-2	Telecom Network Voltages without over voltage
TPE	Twisted-Pair Ethernet
UL	Underwriters Laboratories
VCCI	Voluntary Control Council for Interference
WEEE	Waste from Electrical and Electronic Equipment

## Conventions

The following table describes the conventions used throughout this manual. .

Notation	Description
0x00000000	Typical notation for hexadecimal numbers (digits are 0 through F), for example used for addresses and offsets
0b0000	Same for binary numbers (digits are 0 and 1)
<b>bold</b>	Used to emphasize a word
Screen	Used for on-screen output and code related elements or commands. Sample of Programming used in a table (9pt)
<b>Courier + Bold</b>	Used to characterize user input and to separate it from system output
<i>Reference</i>	Used for references and for table and figure descriptions
File > Exit	Notation for selecting a submenu
<text>	Notation for variables and keys
[text]	Notation for software buttons to click on the screen and parameter description

## About this Manual

Notation	Description
...	Repeated item for example node 1, node 2, ..., node 12
.	Omission of information from example/command that is not necessary at the time
..	Ranges, for example: 0..4 means one of the integers 0,1,2,3, and 4 (used in registers)
	Logical OR
	Indicates a hazardous situation which, if not avoided, could result in death or serious injury
	Indicates a hazardous situation which, if not avoided, may result in minor or moderate injury
	Indicates a property damage message
	Indicates a hot surface that could result in moderate or serious injury
	Indicates an electrical situation that could result in moderate injury or death
<p data-bbox="274 1281 385 1333"><b>Use ESD protection</b></p> 	Indicates that when working in an ESD environment care should be taken to use proper ESD practices
	No danger encountered, pay attention to important information



## Summary of Changes

This manual has been revised and replaces all prior editions.

Document Number	Date	Description
6806800H23X	July 2022	Rebrand for Penguin Solutions. Updated Section 1.1 and Appendix A.
6806800H23W	September 2020	Update for 62368-1 compliance
6806800H23V	November 2019	Rebrand to SMART Embedded Computing template.
6806800H23U	October 2018	Updated to new template, editorial review and updates. Replaced <a href="#">Figure 2-4</a> and <a href="#">Figure 2-5</a> . Removed references to NSC modules and clock cards.
6806800H23T	December 2017	Updated Copyrights page.
6806800H23S	May 2016	Removed Declaration of Conformity (DoC) Updated Copyrights page
6806800H23R	April 2015	Updated <a href="#">Figure 2-4</a> . Removed the Pigeon Point Shelf Release version numbers and moved the PPS manual references from the <a href="#">Table A-1</a> to <a href="#">Table A-2</a> .
6806800H23P	September 2014	Updated the section <a href="#">Grounding the Shelf on page 89</a> .
6806800H23N	August 2014	Added Installation procedure and modified Removal procedure under the section <a href="#">Replacing the PEM on page 112</a> .
6806800H23M	August 2014	Added a caution in the section <a href="#">Fan Speed and Control on page 126</a> .
6806800H23L	July 2014	Updated the section <a href="#">Recommended Power-On Procedures on page 75</a> . Updated <a href="#">Table 2-1</a> under the section <a href="#">Power Consumption</a> .
6806800H23K	May 2014	Rebranded to Artesyn. Updated Declaration of Conformity figure. Updated the sections <a href="#">Grounding the Shelf on page 89</a> , <a href="#">Accessing the System on page 93</a> , <a href="#">RS-232 Serial Interface on page 123</a> and <a href="#">Ethernet Signals on page 131</a> . Updated <a href="#">Figure 7-4 on page 132</a> . Added new sections <a href="#">Configuring Front Panel Network Interface on page 133</a> and <a href="#">Configuring RMCP Network Interface on page 133</a>

## About this Manual

---

Document Number	Date	Description
6806800H23J	July 2013	Updated <a href="#">Figure 2-3</a> .
6806800H23H	April 2013	Updated <a href="#">Receiving and Unpacking the System on page 63</a> , <a href="#">Mounting Options on page 68</a> , <a href="#">Connecting the Cables to the PEM on page 92</a> , <a href="#">Accessing the System on page 93</a> , <a href="#">Installing the Upper FTM on page 115</a> , and <a href="#">Installing the Lower FTM on page 116</a> .
6806800H23G	December 2012	Updated <a href="#">Standard Compliances on page 60</a> .
6806800H23F	October 2012	Updated <a href="#">Figure 1-2 on page 45</a> .
6806800H23E	March 2012	Updated <a href="#">Standard Compliances on page 60</a> . Updated <a href="#">Figure 7-1 on page 121</a> . Updated <a href="#">Ethernet Signals on page 131</a> . Updated <a href="#">System Installation on page 20</a> and <a href="#">System installation on page 30</a> . Updated section <a href="#">EMC on page 19</a> and <a href="#">EMV on page 30</a> .
6806800H23D	April 2011	Updated <a href="#">Figure 2-3 on page 52</a> , <a href="#">Figure 2-4 on page 56</a> , and <a href="#">Hub Slot Connectivity on page 59</a> .
6806800H23C	October 2010	Changed all instances of Centellis 4440 to AXP1440. Added <a href="#">Table 7-10 on page 135</a> . Editorial changes. Updated Declaration of Conformity. Product changed from Centellis 4440 to AXP1440.
6806800H23B	May 2009	Added <a href="#">Figure 1-1 on page 44</a> . Updated <a href="#">Figure 2-3 on page 52</a> . Editorial changes. New layout.
6806800H23A	December 2008	Initial Release

# Safety Notes

---

This section provides warnings that precede potentially dangerous procedures throughout this manual. Instructions contained in the warnings must be followed during all phases of operation, service, and repair of this equipment. You should also employ all other safety precautions necessary for the operation of the equipment in your operating environment. Failure to comply with these precautions or with specific warnings elsewhere in this manual could result in personal injury or damage to the equipment.

Penguin Solutions™ intends to provide all necessary information to install and handle the product in this manual. Because of the complexity of this product and its various uses, we do not guarantee that the given information is complete. If you need additional information, ask your Penguin Solutions representative.

The product has been designed to meet the standard industrial safety requirements. It must only be used in its specific area of office telecommunication industry, industrial control, and development. It must not be used in safety critical components, life supporting devices or on aircraft.

Only personnel trained by Penguin Solutions or persons qualified in electronics or electrical engineering are authorized to install, remove or maintain the product. The information given in this manual is meant to complete the knowledge of a specialist and must not be used as replacement for qualified personnel.

Keep away from live circuits inside the equipment. Operating personnel must not remove equipment covers. Only factory authorized service personnel or other qualified service personnel may remove equipment covers for internal subassembly or component replacement or any internal adjustment.

Do not install substitute parts or perform any unauthorized modification of the equipment or the warranty may be voided. Contact your local Penguin Solutions representative for service and repair to make sure that all safety features are maintained.

## General

### **Danger of Injuries**

At the system's rear there are sharp pins which can cause injuries.

Be careful when handling the system.

## EMC

The product has been tested and found to comply with the limits for a Class A digital device in this system, pursuant to part 15 of the FCC Rules, EN 55022 Class A respectively. These limits are designed to provide reasonable protection against harmful interference when the product is operated in a commercial, business or industrial environment.

## Safety Notes

---

The product generates and uses radio frequency energy and, if not installed properly and used in accordance with this user's documentation, may cause harmful interference to radio communications. Operating the product in a residential area is likely to cause harmful interference, in which case the user will be required to correct the interference at his own expense.

To ensure EMC protection use only shielded cables when connecting peripherals to assure that appropriate radio frequency emissions compliance is maintained. Installed blades must have the face plates installed and all vacant slots in the shelf must be covered.

An AXP1440 that is shipped as a spare, replacement chassis, or an unconfigured system will not have filler panels installed. It is the responsibility of the customer to ensure that all open slots are filled with payload blades, rear transition modules (RTMs), or approved filler panels in order to be compliant with the safety/EMC regulatory markings.

### Grounding

To ensure the system is properly grounded, each of the system's parts must contact the EMI gasket. The system contains gaskets at the shelf and module level.

The shelf is also fitted with ESD contacts. Please take care for proper ESD protection of the operator.

This is a Class A product based on the standard of the Voluntary Control Council for Interference by Information Technology Interference (VCCI). If this equipment is used in a domestic environment, radio disturbance may arise. When such trouble occurs, the user may be required to take corrective actions.

The equipment is suitable for installation in a Common Bonding Network (CBN) or Isolated Bonding Network (IBN).

## System Installation

### System Damage

To avoid system damage verify that the system environment meets the environmental and power requirements given in this manual before installing the system.

Before you begin to set up and cable your new system, consider these guidelines:

- Restricted access area: Install the system only in a restricted access area.
- Installation codes: This unit must be installed in accordance with the National Electrical Code, Articles 110.16, 110.17, and 110.18 and the Canadian Electrical Code, Section 12.a
- Overcurrent protection: A readily accessible listed branch circuit overcurrent protective device must be incorporated into the building wiring. For appropriate AWG rating of the overcurrent protection device see NEC Table 310.16 and other national regulations.

- The protective bonding conductor depends on your power distribution topology. Make sure that you use an appropriate protective bonding conductor regarding the rating of the branch circuit protection.
- Install the system safely. Make sure that cables and cords are out of the way.
- Make sure that the set-up is comfortable for users.

### **System Damage**

WARNING: The intra-building port(s) of the equipment or subassembly is suitable for connection to intra-building or unexposed wiring or cabling only. The intra-building port(s) of the equipment or subassembly **MUST NOT** be metalically connected to interfaces that connect to the OSP or its wiring. These interfaces are designed for use as intra-building interfaces only (Type 2 or Type 4 ports as described in GR-1089) and require isolation from the exposed OSP cabling. The addition of Primary Protectors is not sufficient protection in order to connect these interfaces metalically to OSP wiring.

### **System Damage**

Environmental contamination can impair system operation.

Locate the system in a stable area free of excess movement and jarring and free of dust, smoke, and electrostatic discharge (ESD). Make sure that the temperature does not exceed the operating temperature given in the environmental requirements in this manual and allow room for proper air flow for cooling.

### **Personal Injury or System Damage**

The system is supplied by a TNV2 voltage. This voltage is considered hazardous.

Make sure that the power supply meets the local safety standards.

### **System Overheating**

Improper cooling leads to blade damage.

To ensure proper cooling always operate the system in a horizontal position. Furthermore, keep clear at least 6 cm adjacent to the cooling vents on the chassis front and back side. For detailed information refer to [Site Planning Considerations on page 63](#).

### **Personal or System Damage**

Unstable system installation in a rack can cause the rack to topple over.

Therefore, if your system is the only one in the rack, make sure to mount the system in the lowest part of the rack. If other systems are installed in one rack, start with the heaviest component at the bottom.

If the rack is equipped with stabilizing devices, make sure that they are installed and extended so that the rack is secure. Then proceed to mount or service the system.

## Safety Notes

---

### Personal Injury or System Damage

When pulling the system out of the rack, it can fall down and cause injuries.

Pull out the system cautiously.

### Personal Injury or System Damage

The system is heavy and if you carry it on your own you can hurt your back.

To prevent injury, keep your back straight and have two people lift the system or use additional lifting equipment.

### System Damage

During the course of handling, shipping, and assembly, pins, shrouds and mounting screws, fans and other items can become loose or damaged.

Do not operate a damaged shelf, this can cause damage to devices that interface with it.

### Electrical Hazard



The caution label on the system's rear near the grounding studs shows that you must create an earth connection because there may be a high leakage current which is considered as hazardous.

High leakage current can cause injuries. Therefore, it is essential that you create an earth connection before connecting the PEM to a telecommunication network.

### System Damage

Wrong jumper settings can make the shelf in-operable. Therefore, never change the settings of the jumpers.

## Blade and RTM Installation

### Damage of Circuits

Electrostatic discharge and incorrect RTM or blade installation and removal can damage circuits or shorten their life.

Before touching the RTM, blade or electronic components, make sure that you are working in an ESD-safe environment.

### Installation Sequence of RTMs and AdvancedTCA Blades

If you are going to install an RTM and an AdvancedTCA blade you have to regard the following sequence:

First install the RTM, then install the matching AdvancedTCA blade. Otherwise the blades and RTMs will be damaged.

### **Blade or System Damage**

Installing a blade in the wrong slot causes blade or system damage.

Only install blades in the designated slots.

### **Damage of RTM and Front Blade**

Removing the RTM from the system while the payload of the front blade is powered up may damage the front blade and RTM.

Whenever removing the RTM from the system, you have to power down the payload of the front blade first.

### **RTM Malfunctioning**

Incorrect RTM installation and removal can result in RTM malfunctioning.

When plugging the RTM in or removing it, do not press on the face plate but use the handles.

### **RTM Damage**

Installing the RTM with other blades than the ones designed for it may damage the RTM and the front blade.

Only install the RTM with the correct front blade.

### **Data Loss**

Removing the RTM with the system power on and the blue LED on the front blade still flashing causes data loss.

Before removing the RTM from a powered system, power down the slot by opening the lower handle of the front blade and wait until the blue LED is permanently ON.

### **Blade Malfunctioning**

Incorrect blade installation and removal can result in blade malfunctioning.

Make sure that the blade is connected to the system backplane through all assembled connectors and that power is available on all zone 1 power pins.

## **Operation**

### **System Overheating—Cooling vents**

Improper cooling can lead to blade and system damage.

## Safety Notes

---

To ensure proper cooling and undisturbed airflow through the system always operate the system in a horizontal position and keep clear at least 60 mm at the back of the system. Do not obstruct the ventilation openings at the top and back of the system. Keep the fresh air intake at the bottom front side of the chassis completely clear, and ensure that fresh air supply is not mixed with hot exhaust from other devices.

To ensure proper air flow within the system make sure that all slots are populated with either filler blades, blades or dummy blades.

### **Product Damage**

High humidity and condensation on blade surfaces causes short circuits.

Do not operate the system outside the specified environmental limits. Make sure the system is completely dry and there is no moisture on any surface before applying power. Do not start the system below 0°C.

### **Injury**

Caution: this unit has four -48V to -60V DC feeds. All must be disconnected to de-energize the system. To reduce the risk of injury, disconnect the feeds when removing power from the system.

### **System Damage—Air Filter**

Air contamination can pollute the air filter and obstruct the air intake of the system which may cause system overheating and component damage.

To guarantee proper airflow through the system, the air filter has to be replaced at least every six months. Penguin Solutions recommends to replace the air filter every 90 days. Filter replacement frequency depends on the environment the system is subjected to.

Because central offices vary in physical location and cleanliness, check your air filters every week after you first install your system. In a dusty environment, a filter may need cleaning more often than a filter in a cleaner environment. Check the filters frequently until you have a good idea of how often it needs cleaning. Based on your findings, establish a regular cleaning schedule and keep a log to record the date of each filter cleaning or replacement.

This equipment is designed to permit the connection of the earthed conductor of the DC supply circuit to the earthing conductor at the equipment. If this connection is made, all of the following conditions must be met:

This equipment shall be connected directly to the DC supply system earthing electrode conductor or to a bonding jumper from an earthing terminal bar or bus to which the DC supply system earthing electrode conductor is connected.



This equipment shall be located in the same immediate area (such as, adjacent cabinets) as any other equipment that has a connection between the earthed conductor of the same DC supply circuit and the earthing conductor, and also the point of earthing of the DC system. The DC system shall not be earthed elsewhere.

The DC supply source shall be located within the same premises as this equipment.

Switching or disconnecting devices shall not be in the earthed circuit conductor between the DC source and the point of connection of the earthing electrode conductor.

**French translation:** Cet appareil est conçu pour permettre le raccordement du conducteur relié à la terre du circuit d'alimentation c.c. au conducteur de terre de l'appareil. Pour ce raccordement, toutes les conditions suivantes doivent être respectées:

Ce matériel doit être raccordé directement au conducteur de la prise de terre du circuit d'alimentation c.c. ou à une tresse de mise à la masse reliée à une barre omnibus de terre laquelle est raccordée à l'électrode de terre du circuit d'alimentation c.c.

Les appareils dont les conducteurs de terre respectifs sont raccordés au conducteur de terre du même circuit d'alimentation c.c. doivent être installés à proximité les uns des autres (p.ex., dans des armoires adjacentes) et à proximité de la prise de terre du circuit d'alimentation c.c. Le circuit d'alimentation c.c. ne doit comporter aucune autre prise de terre.

La source d'alimentation du circuit c.c. doit être située dans la même pièce que le matériel.  
- Il ne doit y avoir aucun dispositif de commutation ou de sectionnement entre le point de raccordement au conducteur de la source d'alimentation c.c. et le point de raccordement à la prise de terre.

### **System Overheating**

If you reduce the fan speed, the system temperature will rise.

Constantly control the system temperature once you have reduced the fan speed.

While operating the system ensure that the environmental and power requirements are met.

### **Injuries or Short Circuits—Blade or Power Supply**

In case the ORing diodes of the blade fail, the blade may trigger a short circuit between input line A and input line B so that line A remains powered even if it is disconnected from the power supply circuit (and vice versa).

To avoid damage or injuries, always check that there is no more voltage on the line that has been disconnected before continuing your work.

### Expansion

#### **System Overload**

To avoid an overload of the system check the total power consumption of all components installed (see the technical specification of the respective components). Ensure that any individual output current of any source stays within its acceptable limits (see the technical specification of the respective source).

#### **Loss of Safety Compliance—Using of Additional Plug-in Blades**

By using additional plug-in blades it may be possible that the system may be no more compliant to safety and EMC regulations.

The system integrator has to ensure that the compliancy is guaranteed.

### Exchanging PEMs

#### **Personal Injury through Electric Shock and Burning**

Touching the PEM power input terminals with metallic objects on your hands, wrists, or hanging from your neck may lead to serious injuries like burns or amputations. Do not wear any metallic attire or commodity on your hands, wrists, or hanging from your neck when working at the power input terminals or power input cables. Be extremely careful when you use electrically conductive tools near the PEMs.

#### **Short Circuits or Personal Injury**

Ensure that the power feeds you plan to remove or attach are powered off and cannot be switched on while you are working.

#### **Short Circuit and Electric Shock**

To avoid short circuits and electric shock, the power lugs must not be energized before removing the screws. It is essential to ensure that the power lugs are not energized before loosening the screws. Be careful with the used tools in order to prevent a short circuit.

#### **PEM Damage**

Applying reversal power causes damage to the electrolytic capacitors of the filter. Therefore, only switch on the breakers if no red light is visible.

### Exchanging Fans

#### **Personal Injury—Rotating Fans**

Inserting tools or fingers into operational fans may cause injuries.

Fans become exposed when the fan tray is pulled. Keep clear of the fans as long as they are rotating.

When the fan is removed, extreme care should be taken while handling the fan itself. The centrifugal forces will make the unit difficult to handle.

## Cabling

### Personal Injury

The cabling should follow existing cable paths using existing or similar cable fastenings.

Never change the system's cabling as delivered by Penguin Solutions. Check proper function of the system after cabling extensions. To avoid injuries always ensure that cables are securely installed so that nobody can trip over them.

### Personal Injury through Electric Shock

Touching contacts and cables during system operation can cause injuries through electric shock.

To avoid electric shock make sure that contacts and cables of the system cannot be touched while the system is operating. If in doubt concerning cabling, ask your local Penguin Solutions representative.

The Interphase boards ARTM 6499 and PMC module 4538 are not certified for the use with TNV-1 circuits. Do not connect E1/T1/J1 lines directly to the ARTM 6499. Use a Digital Service Unit/Control Service Unit (DSU/CSU) to eliminate over voltages.

The Intel RTM ARTM-MPRTM0020 is not certified for the use with TNV-1 circuits. Do not connect E1/T1/J1 lines directly to the ARTM-MPRTM0020. Use a Digital Service Unit/Control Service Unit (DSU/CSU) to eliminate over voltages.

### Cable Damage

Folding the fiber cable damages the cable and inhibits the data transmission. Therefore, make sure you do not fold the cable.

## RJ-45 Connector

### System Damage

RJ-45 connectors on blades are either twisted-pair Ethernet (TPE) or E1/T1/J1 network interfaces. Connecting an E1/T1/J1 line to an Ethernet connector may damage your system.

Make sure that TPE connectors near your working area are clearly marked as network connectors.

## Safety Notes

---

Verify that the length of an electric cable connected to a TPE bushing does not exceed 100m.

Make sure the TPE bushing of the system is connected only to safety extra low voltage circuits (SELV circuits).

If in doubt, ask your system administrator.

## Laser

### Personal Injury

Some variants of the blades in the system are Class 1 laser products. The use of controls or adjustments or performance of procedures other than those specified herein may result in hazardous radiation exposure.

Some variants of the RTM are a Class 1 laser product. The use of controls or adjustments or performance of procedures other than those specified herein may result in hazardous radiation exposure.

## Battery

### Blade Damage

Wrong battery installation may result in hazardous explosion and blade damage.

Always use the same type of battery as is installed and make sure the battery is installed as described in the user manual of the blade.

Always dispose of old batteries according to your country's legislation.

## Environment

### Environmental

Always dispose of used blades, system components and RTMs according to your country's legislation and manufacturer's instructions.

# Sicherheitshinweise

---

Dieses Kapitel enthält Hinweise, die potentiell gefährlichen Prozeduren innerhalb dieses Handbuchs vorrangestellt sind. Beachten Sie unbedingt in allen Phasen des Betriebs, der Wartung und der Reparatur des Systems die Anweisungen, die diesen Hinweisen enthalten sind. Sie sollten außerdem alle anderen Vorsichtsmaßnahmen treffen, die für den Betrieb des Systems innerhalb Ihrer Betriebsumgebung notwendig sind. Wenn Sie diese Vorsichtsmaßnahmen oder Sicherheitshinweise, die an anderer Stelle dieses Handbuchs enthalten sind, nicht beachten, kann das Verletzungen oder Schäden am System zur Folge haben.

Penguin Solutions™ ist darauf bedacht, alle notwendigen Informationen zum Einbau und zum Umgang mit dem System in diesem Handbuch bereit zu stellen. Da es sich jedoch bei dem System um ein komplexes Produkt mit vielfältigen Einsatzmöglichkeiten handelt, können wir die Vollständigkeit der im Handbuch enthaltenen Informationen nicht garantieren. Falls Sie weitere Informationen benötigen sollten, wenden Sie sich bitte an die für Sie zuständige Geschäftsstelle von Penguin Solutions.

Das System erfüllt die für die Industrie geforderten Sicherheitsvorschriften und darf ausschließlich für Anwendungen in der Telekommunikationsindustrie, im Zusammenhang mit Industriesteuerungen und in der Entwicklung verwendet werden. Es darf nicht in sicherheitskritischen Anwendungen, lebenserhaltenden Geräten oder in Flugzeugen verwendet werden.

Einbau, Wartung und Betrieb dürfen nur von durch Penguin Solutions ausgebildetem oder im Bereich Elektronik oder Elektrotechnik qualifiziertem Personal durchgeführt werden. Die in diesem Handbuch enthaltenen Informationen dienen ausschließlich dazu, das Wissen von Fachpersonal zu ergänzen, können dieses jedoch nicht ersetzen.

Halten Sie sich von stromführenden Leitungen innerhalb des Systems fern. Entfernen Sie auf keinen Fall die Systemabdeckung. Nur werksseitig zugelassenes Wartungspersonal oder anderweitig qualifiziertes Wartungspersonal darf die Systemabdeckung entfernen, um Systemkomponenten zu ersetzen oder andere Anpassungen vorzunehmen.

Installieren Sie keine Ersatzteile oder führen Sie keine unerlaubten Veränderungen am System durch, sonst verfällt die Garantie. Wenden Sie sich für Wartung oder Reparatur bitte an die für Sie zuständige Geschäftsstelle von Penguin Solutions. So stellen Sie sicher, dass alle sicherheitsrelevanten Aspekte beachtet werden.

## Allgemein

### **Verletzungsgefahr**

An der Rückseite des Systems befinden sich spitze Stifte, an denen Sie sich verletzen können.

Seien Sie vorsichtig im Umgang mit dem System.

### EMV

Das Produkt wurde getestet und erfüllt die für digitale Geräte der Klasse A gültigen Grenzwerte gemäß den FCC-Richtlinien Abschnitt 15 bzw. EN 55022 Klasse A. Diese Grenzwerte sollen einen angemessenen Schutz vor Störstrahlung beim Betrieb des Produkts in Geschäfts-, Gewerbe- sowie Industriebereichen gewährleisten.

Das Produkt arbeitet im Hochfrequenzbereich und erzeugt Störstrahlung. Bei unsachgemäßem Einbau und anderem als in diesem Handbuch beschriebenen Betrieb können Störungen im Hochfrequenzbereich auftreten.

Benutzen Sie zum Anschließen von Peripheriegeräten ausschließlich abgeschirmte Kabel. So stellen Sie sicher, dass ausreichend Schutz vor Störstrahlung vorhanden ist. Die Blades müssen mit der Frontblende installiert und alle freien Steckplätze müssen mit Blindblenden abgedeckt sein.

Ein AXP1440, das als Ersatzteil, Austauschchassis oder unkonfiguriertes System ausgeliefert wird, enthält keine Platzhalter-Boards. Es liegt in der Kundenverantwortung sicherzustellen, dass alle leeren Steckplätze mit Boards, RTMs oder zugelassenen Platzhalter-Boards belegt sind, um die Sicherheits- und EMC-Vorschriften zu erfüllen.

#### **Erdung**

Um eine korrekte Erdung des Systems zu gewährleisten, befinden sich sowohl am System als auch an den einzelnen Modulen Dichtungen. Stellen Sie sicher, dass alle Systemteile die EMI Dichtung berühren.

Am System befinden sich auch ESD Kontakte. Stellen Sie sicher, dass jede Person, die mit dem System arbeitet, mit ESD-Schutz, zum Beispiel ESD Bändern, ausgerüstet ist.

Das Produkt ist eine Einrichtung der Klasse A gemäß dem Standard des Voluntary Control Council for Interference von Information Technology Interference (VCCI). Wird das Produkt in Wohngebieten betrieben, können Störungen im Hochfrequenzbereich auftreten. In einem solchen Fall ist der Benutzer verpflichtet, entsprechende Gegenmaßnahmen zu ergreifen.

Das Produkt ist für den Einsatz in Netzwerken mit gemeinsamem Potentialausgleich oder mit isoliertem Potentialausgleich geeignet.

## Systeminstallation

### **Beschädigung des Systems**

Bevor Sie das System installieren, überprüfen Sie, ob die im Handbuch beschriebenen Anforderungen erfüllt werden.

Beachten Sie folgende allgemeinen Sicherheitshinweise vor der Installation und Verkabelung des Systems:

- Bereich mit eingeschränktem Zugang - Installieren Sie das System nur in Bereichen mit eingeschränktem Zugang.
- Installationsrichtlinien: Dieses System muss gemäß folgender Richtlinien installiert werden: National Electrical Code, Artikel 110.16, 110.17 und 110.18 und Canadian Electrical Code, Abschnitt 12.a
- Überstrom Schutzvorrichtung - Eine leicht zugängliche Trennvorrichtung muss in der Gebäudeverkabelung eingebaut sein. Einen angemessenen AWG (American Wire Gauge - amerikanische Norm für Drahtquerschnitte) Wert der Überstrom Schutzvorrichtung können Sie der NEC (National Electrical Code) Tabelle 310.16 oder anderen nationalen Regelwerken entnehmen.
- Der Erdungsleiter ist abhängig von der Spannungsverteilungstopologie innerhalb Ihrer Anlage. Stellen Sie sicher, dass Sie einen angemessenen Erdungsleiter gemäß der Auslegung des Zugangsleitungsschutzes verwenden.
- Bauen Sie das System sicher ein. Stellen Sie sicher, dass Kabel und Leitungen nicht im Weg sind.
- Stellen Sie sicher, dass der Systemaufbau anwenderfreundlich ist.

### **Beschädigung des Systems**

Die Gebäude-internen Schnittstellen ("intra-building ports" per GR-1089-CORE) der Geräte oder Baugruppen sind nur für gebäudeinterne Verkabelung vorgesehen. Die Schnittstellen sind als Typ 2 oder Typ 4 definiert (wie in GR-1089-Core beschrieben) und erfordern eine Isolation zu Leitungen außerhalb des Gebäudes.

Die Gebäude-internen Schnittstellen dürfen keine elektrisch leitende Verbindung zu Leitungen außerhalb des Gebäudes haben. Ein "Primary Protector" (wie in GR-1089-CORE beschrieben) ist keine ausreichende Absicherung, um die Gebäude-internen Schnittstellen mit Leitungen außerhalb des Gebäudes zu verbinden.

### **Beschädigung des Systems**

Verschmutzungen können das System beschädigen.

Betreiben Sie das System an einem erschütterungsfreien Ort, an dem weder Staub, Rauch noch elektrostatische Entladungen auftreten. Stellen Sie außerdem sicher, dass die klimatischen Bedingungen, die in diesem Handbuch spezifiziert sind, eingehalten werden und genug Raum für die Luftzirkulation vorhanden ist.

### **Verletzungsgefahr und Beschädigung des Systems**

Das System ist an eine TNV-2 Spannungsquelle angeschlossen. Diese Spannung kann gefährlich sein.

Stellen Sie sicher, dass die externe Spannungsversorgung den entsprechenden Sicherheitsstandards entspricht.

### System Überhitzung

Unzureichende Kühlung kann zu einer Beschädigung der Boards führen.

Um eine ausreichende Kühlung sicherzustellen betreiben Sie das System nur aufrecht. Sorgen Sie außerdem dafür, dass ein ausreichender Mindestabstand (mindestens 6 cm) vor den Lüftungsschlitzen an der Vorder- und Rückseite des Systems freigehalten wird. Genaue Informationen finden Sie im Kapitel [Site Planning Considerations on page 63](#).

### Verletzungsgefahr und Beschädigung des Systems

Wenn die Gewichte im Schaltschrank ungleich verteilt sind, kann der Schaltschrank umkippen.

Bauen Sie das System deshalb ganz unten im Schrank ein, wenn es das einzige System im Schrank ist. Wenn mehrere Systeme in einen Schrank eingebaut werden sollen, platzieren Sie das schwerste System ganz unten und die leichteren weiter oben. Falls der Schaltschrank mit Kippsicherungen ausgestattet ist, stellen Sie sicher, dass diese auch installiert und ausgefahren sind, um einen sicheren Stand des Schanks zu gewährleisten. Beginnen Sie erst danach mit dem Einbau oder der Wartung des Systems.

### Verletzungsgefahr oder Beschädigung des Systems

Das System kann beim Herausziehen herunterfallen und Verletzungen verursachen.

Ziehen Sie das System vorsichtig heraus, damit es nicht herunterfällt.

### Verletzungsgefahr oder Beschädigung des Systems

Das System ist schwer, und wenn Sie es alleine tragen, kann dies zu Rückenschäden führen.

Heben Sie deshalb das System nur zu zweit und halten Sie beim Heben Ihren Rücken gerade oder benutzen Sie zusätzliche Hilfsmittel.

### Beschädigung des Systems

Während des Transportes und Zusammenbaus des Systems können sich Teile, wie zum Beispiel Schrauben, Blenden, Stecker oder Lüfter lösen oder beschädigt werden.

Nehmen Sie das System nicht in Betrieb, wenn Teile beschädigt sind. Dies könnte zu Beschädigungen an anderen Teilen führen.

### Hoher Ableitstrom



Dieser Aufkleber befindet sich in der Nähe der Schutzleiter auf der Rückseite des Systems und warnt, dass Sie vor der Inbetriebnahme eine Erdung durchführen müssen, da hier ein hoher Ableitstrom vorhanden sein kann.

Hoher Ableitstrom kann zu Verletzungen führen.



Stellen Sie deshalb vor Anschluss des Systems an ein Telekommunikationsnetz unbedingt eine Erdungsverbindung her.

### **Beschädigung des Systems**

Falsche Jumper-Einstellungen können dazu führen, dass das System nicht mehr funktioniert. Ändern Sie deshalb nie die Einstellungen der Jumper.

## **Board und RTM Installation**

### **Beschädigung des Boards**

Berühren Sie das Board oder elektrische Komponenten in einem nicht ESD-geschützten Bereich, kann dies zu einer Beschädigung des Boards führen.

Bevor Sie Boards oder elektronische Komponenten berühren, vergewissern Sie sich, dass Sie in einem ESD-geschützten Bereich arbeiten.

### **Reihenfolge bei der Installation von RTMs und AdvancedTCA Boards**

Die folgende Reihenfolge muß bei der Installation von RTMs und AdvancedTCA Boards eingehalten werden:

Installieren Sie zuerst das RTM und erst danach das passende AdvancedTCA Board. Ansonsten können RTM oder Board beschädigt werden.

### **Beschädigung des Boards oder Systems**

Wird ein Board in den falschen Steckplatz im System gesteckt, können sowohl das Board als auch das System beschädigt werden. Installieren Sie Boards deshalb ausschließlich in dafür vorgesehene Steckplätze.

### **Beschädigung des RTMs oder Boards**

Wird das RTM ausgebaut, während die Payload des dazugehörigen AdvancedTCA Boards noch nicht heruntergefahren ist, kann dies zu Beschädigungen am Board oder RTM führen.

Fahren Sie deshalb die Payload des AdvancedTCA Blades immer herunter, bevor Sie das dazugehörige RTM aus dem System entfernen.

### **Beschädigung des RTMs**

Fehlerhafte Installation kann zu einer Beschädigung des RTMs führen. Verwenden Sie die Handles, um das RTM zu installieren/deinstallieren. Auf diese Weise vermeiden Sie, dass die Frontblende oder die Platine deformiert oder zerstört werden.

## Sicherheitshinweise

---

### **Beschädigung des RTMs oder Boards**

Das System wird beschädigt, wenn die RTMs nicht zu den von vorne in dem System installierten Boards passen.

Stellen Sie deshalb sicher, dass Boards und RTMs, die von vorne bzw. von hinten in den gleichen Steckplatz des Systems eingebaut werden, stets zueinander passen.

### **Datenverlust**

Das Entfernen eines RTMs während des Systembetriebs und blinkender blauer LED des Front Boards führt zu Datenverlust.

Vor dem Entfernen des RTMs im laufenden Systembetrieb, schalten Sie das entsprechende Board ab, indem Sie die Griffe des Boards öffnen. Warten Sie, bis die blaue LED dauerhaft leuchtet.

### **Fehlfunktion**

Unsachgemäßer Ein- und Ausbau von Boards kann zu einer Fehlfunktion des Boards führen.

Vergewissern Sie sich, dass das Board über alle Stecker an die AdvancedTCA-Backplane angeschlossen und die Stromversorgung gewährleistet ist.

## Betrieb

### **Überhitzung des Systems–Lüftungsschlitze**

Unzureichende Lüftung kann Schäden an Boards und am System verursachen.

Um eine ausreichende Lüftung zu gewährleisten, stellen Sie sicher, dass das System während des Betriebs stets waagrecht steht und dass ein Freiraum von mindestens 60 mm an der Rückseite des Systems vorhanden ist. Halten Sie die Lüftungsschlitze an der Oberseite und der Rückseite des Systems frei. Halten Sie die Frischluftzufuhröffnung an der unteren Vorderseite des Systems völlig frei und stellen Sie sicher, dass sich die Frischluft nicht mit der Abluft von anderen Systemen mischt.

Um eine ungestörte Luftzirkulation zu gewährleisten, stellen Sie sicher, dass alle Steckplätze mit Boards oder Platzhaltern belegt sind.

### **Beschädigung des Systems**

Durch hohe Luftfeuchtigkeit können Kurzschlüsse entstehen.

Betreiben Sie das System nur innerhalb der angegebenen Grenzwerte für die relative Luftfeuchtigkeit und Temperatur. Stellen Sie vor dem Einschalten des Stroms sicher, dass sich auf dem System und auf den Boards kein Kondensat befindet und starten Sie das System nicht unter 0°C.

### **Stromschlaggefahr**

Das System besitzt vier -48V bis -60V DC Anschlüsse. Alle Anschlüsse müssen vom System entfernt werden, um das System spannungsfrei zu schalten.

Um eine Verletzungsgefahr zu minimieren, entfernen Sie die Anschlüsse, wenn Sie das System ausschalten.

### **Beschädigung des Systems–Luftfilter**

Verunreinigungen in der Luft können den Luftfilter verschmutzen und so die Luftzufuhr des Systems beeinträchtigen. Das kann zur Überhitzung des Systems und zu Schäden an Systemteilen führen.

Um einen reibungslosen Luftstrom durch das System zu gewährleisten, sollten Sie den Luftfilter spätestens alle sechs Monate austauschen. Penguin Solutions empfiehlt, die Lüfter alle 90 Tage auszutauschen. Wie häufig Sie die Filter austauschen müssen, hängt von der Umgebung ab, in der das System betrieben wird. Da die Verhältnisse in Vermittlungsstellen sehr unterschiedlich sein können, sollten Sie die Luftfilter nach der Erstinstallation des Systems jede Woche kontrollieren. In einer staubigen Umgebung muss ein Filter gegebenenfalls öfter gereinigt werden als in einer saubereren Umgebung. Prüfen Sie den Filter regelmäßig bis Sie eine Vorstellung davon haben, wie oft der Filter gereinigt werden muss. Erstellen Sie aufgrund Ihrer Beobachtungen einen Reinigungsplan und protokollieren Sie jede Reinigung oder jeden Austausch des Filters.

### **Überhitzung des Systems**

Wenn Sie die Geschwindigkeit der Lüfter reduzieren, steigt die Systemtemperatur an. Kontrollieren Sie deshalb ständig die Temperatur im System, wenn Sie die Geschwindigkeit der Lüfter reduziert haben. Stellen Sie während des Betriebs sicher, dass die Bedingungen, die im Handbuch beschrieben sind, eingehalten werden.

### **Verletzungen oder Kurzschlüsse**

Blade oder Stromversorgung

Falls die ORing Dioden des Blades durchbrennen, kann das Blade einen Kurzschluss zwischen den Eingangsleitungen A und B verursachen. In diesem Fall ist Leitung A immer noch unter Spannung, auch wenn sie vom Versorgungskreislauf getrennt ist (und umgekehrt).

Prüfen Sie deshalb immer, ob die Leitung spannungsfrei ist, bevor Sie Ihre Arbeit fortsetzen, um Schäden oder Verletzungen zu vermeiden.

### Ausbau/Erweiterung

#### **Systemüberlastung**

Verhindern Sie eine Systemüberlastung, indem Sie die gesamte aufgenommene Leistung aller eingebauten Komponenten, also z.B. der installierten Blades und Laufwerke (siehe die technischen Daten der entsprechenden Komponente) überprüfen. Stellen Sie sicher, dass der Ausgangsstrom jedes Verbrauchers innerhalb der zulässigen Grenzwerte liegt.

#### **Verlust der Sicherheitszulassung–Verwendung zusätzlicher Module**

Wenn Sie zusätzliche Module und Boards verwenden, ist es möglich, dass das System nicht mehr den gültigen Sicherheits- und EMV Normen entspricht. Der Systemintegrator muss die Einhaltung der gültigen Normen sicherstellen.

### Austausch von PEMs

#### **Verletzungsgefahr durch Stromschlag und Verbrennungen**

Berühren metallische Gegenstände an Händen, Handgelenken oder am Hals die Input Terminals der PEMs, kann dies zu extremen Verletzungen, wie zum Beispiel Verbrennungen oder Amputationen führen. Tragen Sie bei der Arbeit mit dem System keine metallischen Gegenstände an Ihren Händen oder Armen und lassen sie keine metallischen Gegenstände um Ihren Hals hängen. Seien Sie extrem vorsichtig mit elektrisch leitenden Gegenständen in der Nähe der PEMs.

#### **Kurzschluß und Gefahr durch Stromschlag**

Um einen elektrischen Schlag zu vermeiden, überzeugen Sie sich, dass vor dem Austausch des PEMs die Stromzufuhr unterbrochen ist und während des Austausches unterbrochen bleibt.

#### **Kurzschluß und Gefahr durch Stromschlag**

Um Kurzschlüsse und elektrischen Schlag zu vermeiden, überzeugen Sie sich, dass vor dem Lösen der Schrauben die Stromzufuhr unterbrochen ist und während des Austausches unterbrochen bleibt. Vermeiden Sie Kurzschlüsse, indem Sie sehr vorsichtig mit dem Werkzeug umgehen.

#### **Beschädigung der Spannungsversorgungseinheit**

Wir die Spannungsversorgungseinheit verkehrt angeschlossen, werden die Elektrolytkondensatoren der Filter beschädigt. Schalten Sie die Unterbrecher deshalb nur, wenn das rote Licht nicht sichtbar ist.

### Lüfteraustausch

#### **Verletzungsgefahr–Rotierende Lüfterschaufeln**

Sie können verletzt werden, wenn Sie Werkzeuge oder Finger in laufende Lüfter einführen.

Wenn Sie die Lüfterschublade aus dem Chassis ziehen, wird die Abdeckung der Lüfterschaufeln freigelegt. Berühren Sie die Lüfterschaufeln nicht.

Seien Sie vorsichtig nach dem Herausziehen des Lüfters, da die Zentrifugalkräfte noch wirken und somit die Handhabung erschweren können.

### Verkabelung/Kabelführung

#### **Verletzungsgefahr**

Verändern Sie nie die von Penguin Solutions ausgelieferte Verkabelung des Systems.

Stellen Sie sicher, dass die Verkabelung schon existierenden Kabelführungen folgt und bestehende oder ähnliche Befestigungen verwendet. Überprüfen Sie nach der Erweiterung der Verkabelung, ob das System ordnungsgemäß arbeitet.

Reduzieren Sie die Verletzungsgefahr, indem Sie Kabel so verlegen, dass niemand darüber stolpern kann.

#### **Verletzungsgefahr durch Stromschlag**

Durch das Berühren von Kontakten und Kabeln während des Betriebs können Sie einen elektrischen Schlag bekommen.

Schließen Sie in jedem Fall aus, dass Personen durch einen elektrischen Schlag verletzt werden können, indem Sie sicherstellen, dass Kontakte und Kabel des Systems während des Betriebs nicht berührt werden können.

Falls Sie Fragen bezüglich der Verkabelung haben, wenden Sie sich an die für Sie zuständige Geschäftsstelle von Penguin Solutions.

Das Interphase Board ARTM-6499 und das Interphase PMC Module 4538 sind nicht für den Betrieb mit einer TNV-1 Spannung zertifiziert. Verbinden Sie E1/T1/J1 nicht direkt mit der TNV-1 Spannung. Verwenden Sie eine Digital Service Unit/Control Service Unit (DSU/CSU), um Ueberspannungen zu vermeiden.

Das Intel RTM ARTM-MPRTM0020 ist nicht für den Betrieb mit einer TNV-1 Spannung zertifiziert. Verbinden Sie E1/T1/J1 nicht direkt mit der TNV-1 Spannung. Verwenden Sie eine Digital Service Unit/Control Service Unit (DSU/CSU) um Ueberspannungen zu vermeiden.

## Sicherheitshinweise

---

### **Beschädigung der Kabel**

Werden Kabel geknickt, kann das Kabel beschädigt werden und der Datentransfer nicht mehr stattfinden. Stellen Sie sicher, dass Kabel nicht geknickt werden.

## RJ-45 Stecker

### **Beschädigung des Systems**

Bei den RJ-45 Steckern, die sich auf den Boards befinden, handelt es sich entweder um Twisted-Pair-Ethernet (TPE) oder um E1/T1/J1-Stecker. Beachten Sie, dass ein versehentliches Anschließen einer E1/T1/J1 Leitung an einen TPE-Stecker Ihr System zerstören kann.

Kennzeichnen Sie deshalb TPE-Anschlüsse in der Nähe Ihres Arbeitsplatzes deutlich als Netzwerkanschlüsse.

Stellen Sie sicher, dass die Länge eines mit Ihrem Systems verbundenen TPE-Kabels 100 m nicht überschreitet.

Das System darf über die TPE Stecker nur mit einem Sicherheits-Kleinspannungs-Stromkreis (SELV) verbunden werden.

Bei Fragen wenden Sie sich an Ihren Systemverwalter.

## Laser

### **Verletzungsgefahr**

Einige Boards, die in verschiedenen Systemkonfigurationen verwendet werden, sind Laserprodukte der Klasse 1. Verwenden Sie diese anders als in der Dokumentation beschrieben, kann dies zu gefährlicher Strahlung führen.

Einge RTMs sind Laserprodukte der Klasse 1. Verwenden Sie diese anders als in der Dokumentation beschrieben, kann dies zu gefährlicher Strahlung führen.

## Batterieaustausch

### **Beschädigung der Boards**

Ein unsachgemäßer Austausch von Batterien kann zu gefährlichen Explosionen und Beschädigung der Boards führen.

Verwenden Sie deshalb nur den Batterietyp, der auch bereits eingesetzt wurde und befolgen Sie die entsprechende Anleitung im Installationshandbuch des jeweiligen Boards.

Entsorgen sie alte Batterien entsprechend der in Ihrem Land gültigen Richtlinien.

## **Umweltschutz**

### **Umweltschutz**

Entsorgen Sie alte Blades, RTMs und Systeme gemäß der in Ihrem Land gültigen Gesetzgebung und den Empfehlungen des Herstellers.





# Platform Architecture

## 1.1 Description

The Penguin Edge™ AXP1440 shelf is designed as an open standard platform to accommodate off-the-shelf ATCA switch and payload blades. It combines existing PICMG standards featuring high speed serial data fabrics. These standards serve to streamline the architecture by eliminating the overhead of bridging, increasing the payload, and eliminating the need for system and non-system slot blades. This is accomplished by using the Intelligent Platform Management Interface (IPMI) and dual Ethernet star network which allows for communication between all node blades using Ethernet.

The AXP1440 is a high-availability platform with special locations for Shelf Management Alarm Module (SAMs) and fourteen 8U x 280 mm slots, fourteen 8U x 70 mm Rear Transition Modules (RTMs), Fan Tray Modules (FTMs), and Power Entry Modules (PEMs).

Commercial off-the shelf (COTS) ruggedized configurations of the AXP1440 shelf are also available (AXP1440-C06 and AXP1440-C07). These ruggedized configurations have thickened walls that enhance the chassis stability and are designed to withstand higher shock and vibration requirements in harsh environments. The COTS ruggedized configurations also have provisions to secure payload and switch blades in place using captive screws through the backplane into the alignment blocks of our ruggedized switch and payload boards.

This manual is specific to the non-ruggedized AXP1440 shelf. For installation and use manuals specific to the AXP1440-C06 or AXP1440-C07 ruggedized configurations, please refer to [Appendix A, Penguin Solutions Documentation, on page 139](#), or contact your local Penguin Solutions sales representative.



**SMART Embedded Computing company branding has changed to Penguin Solutions™. The SMART Embedded Computing product line has been rebranded as Penguin Edge™. No changes were made to the AXP1440 product line through this rebranding of the company and product line in April of 2022.**

## 1.2 PICMG Compliance

The AXP1440 is designed to be compliant with PCI Industrial Computers Manufacturer's Group (PICMG) specifications 3.0 and 3.1, and also provides support for PICMG 1.5.1 IPMI bus for system management.

### 1.3 Shelf Topology

Topology refers to the shape of a network, or the network's physical layout. The way that different nodes in a network are connected to each other and how they communicate are determined by the network's topology.'

The backplane of the AXP1440 uses a dual star topology that supports two independent networks. The dual star uses a point-to-point configuration with redundancy added for reliability. All devices on a star network are connected to a central connection point (hub). Nodes communicate across the network by passing data through the hub slot, which on the AXP1440 contains a switching function that forwards packets to the appropriate port based on the packet's address. Switching hubs support traditional Ethernet (10 Mbps), Fast Ethernet (100 Mbps), and Gigabit Ethernet (1000 Mbps) ports.

### 1.4 Network Descriptions

This section describes the operational aspects of each of the shelf's network designs, based on Base and Fabric interfaces.

#### 1.4.1 Base Interface

#### **NOTICE**

**The blade slots are numbered physically from 1 to 14 going left to right along the front of the shelf. Each slot also has a logical slot number that defines it for backplane connectivity; logical slot numbers are not shown on the shelf. Please note that the slots are referred to by their physical slot location.**

The base hub slots (physical slots 6 and 9) have four pairs of 1000Base-T signals to node slots which form the dual star topology fabric. Each of the node slots support two base channel interface signals that connect to each hub slot. In turn, the channel 1 base interface of each hub slot is connected to the SAM. Each of the hub slots support a total of 14 base channels.

The hub slots require connectors P23 and P24. The base node slots require only connector P23.

### 1.4.2 Fabric Interface

The fabric interface supports point-to-point connections between AdvancedTCA blades. In the AXP1440, these fabric connections are configured in a dual star topology that runs back to the hub slots. The AXP1440 system has Option 9 channel slots. These channels are aggregated at the hub slots into the dual-star topology. In this configuration, all node slots support one fabric channel to each of the two hub slots. The fabric channels are located on connector P20 of the node slots, and connectors P20, P21, P22, and P23 of the hub slots.

The implementation of the interface is indicated by the level of PICMG compliance a blade or hub is designed to. The AXP1440 supports the PICMG 3.1 fabric standard to allow for several configuration options that can provide greater bandwidth to certain slots in the shelf. The fabric interface switch supports: PICMG 3.1 Option 9 (10 Gbps). The following figure shows the AXP1440 shelf update channel connectivity.

A PICMG 3.1 compliant hub provides 10GBASE-BX4 to the fabric interface of a PICMG 3.1 compliant blade.

The fabric interface switch is also extended outside the AXP1440 shelf through eight external connectors on the RTM.

### 1.4.3 IPMI Network

The Intelligent Platform Management Interface (IPMI) is based on a redundant radial topology. Redundant IPMI networks are supported by the Shelf Management Alarm Module (SAM) to manage the shelf resources.

The SAM is the center of the IPMI network; hubs are the center of the Base Interface network. The SAM connects to all slots in the shelf and monitors and reports on the content of the AXP1440. The SAM collects environmental data from sensors within the shelf and can assist high availability software to determine when a failover is necessary due to hardware removal or environmental changes, such as an over-temp condition.

The SAMs contain the Shelf Management Controller (ShMC) which polls all devices resident to the shelf and collects the FRU data records for all the components. The SAM also manages non-IPMI devices for the shelf and performs environmental monitoring of the temperature and voltage. Using the PICMG 3.0 standard, the SAM is able to power off and reset slots for hot swap capability.

## 1.4.4 Update Channel Interface

The update channel interface consists of 10 differential pairs on the P20 connector. The physical layer and protocol used on this interface is application specific.

Figure 1-1 Update Channel

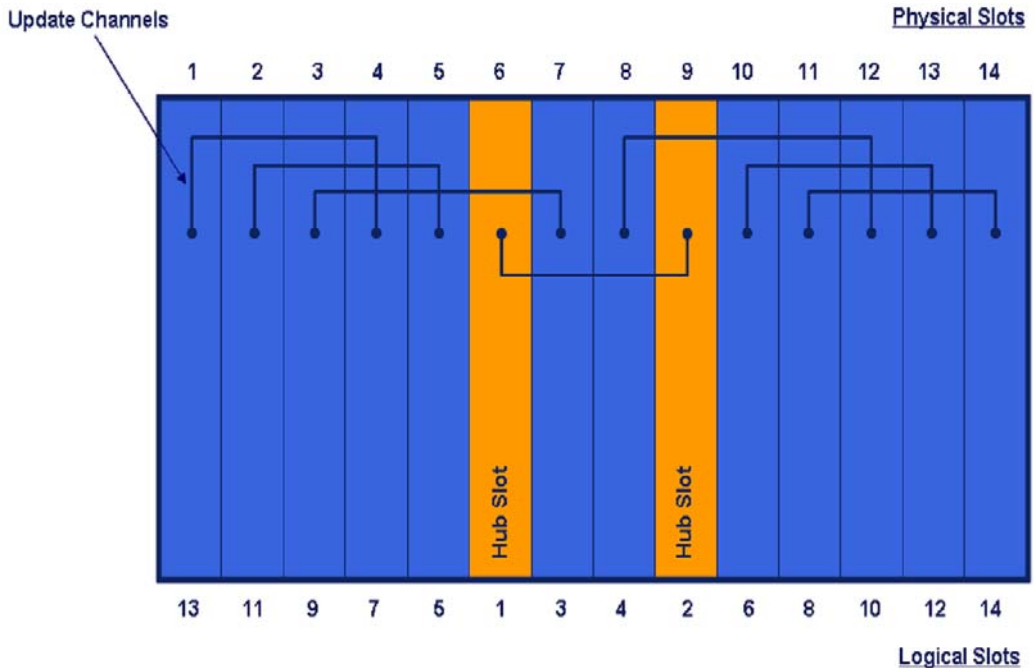

## 1.5 Backplane and Component Connectivity

The blade connectivity on the AXP1440 backplane is divided among three zones, each with the following characteristics:

- Zone 1 provides redundant, radial IPMI to all blade slots and redundant -48 VDC to all blade slots
- Zone 2, the data transport interface, provides the dual star configuration for the base interface, dual star configuration for the fabric interface, update channel routing for all blade slots, and three redundant, bussed telecom clock signals to all blade slots
- Zone 3 provides the PICMG 3.0 defined open area that is application-specific

**NOTICE**

**Rear Transition Modules connect directly with the connectors on the front-side blade and do not make the connection through the backplane.**

Figure 1-2 Location of Zones 1, 2, and 3

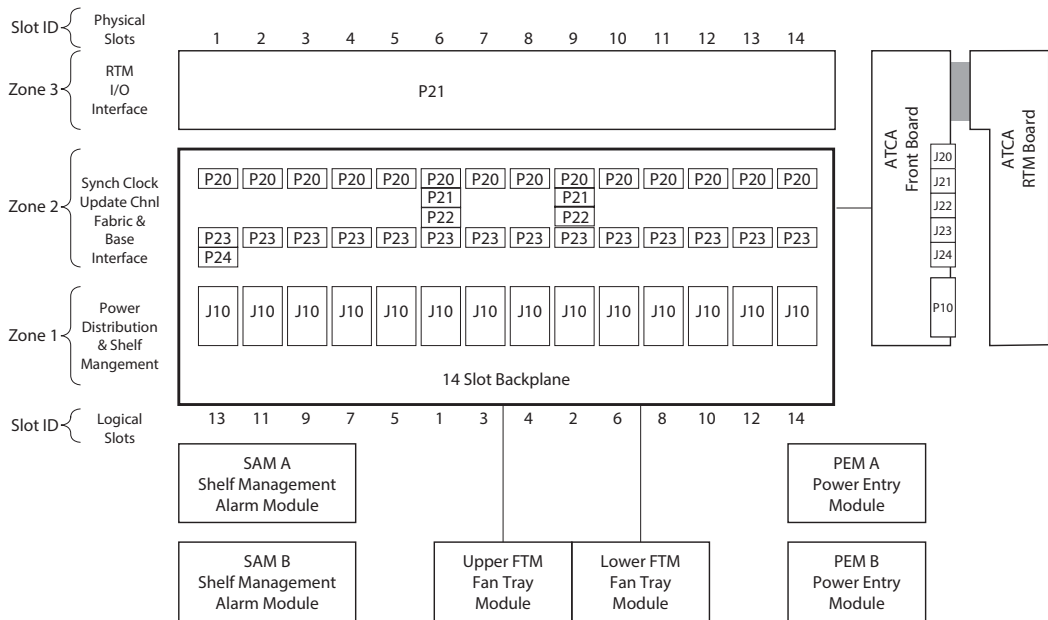

## 1.6 Operating Systems

The AXP1440 comes installed with the following software:

- Wind River PNE-LE-2.0
- Enhanced Basic Blade Services (BBS)

For more information, contact your Penguin Solutions sales representative for other software products for your configuration.

# 1.7 Remote Management and Maintenance

The AXP1440 supports remote critical management and maintenance procedures. This eliminates the need for on-site maintenance personnel to handle routine maintenance tasks. A standard Telnet connection for remote access to networked functionality provides the ability to:

- Upgrade IPMI firmware flashed on the SAMs, PEMs, FTMs, node and hub blades
- Upgrade BIOS
- Access in-service application software upgrades
- Access IPMI event logs for performance monitoring
- Access custom designed-in functionality or event logs

# AXP1440 Shelf Description

---

## 2.1 Overview

The AXP1440 Shelf supports 14 AdvancedTCA blade slots, of which 12 are I/O node slots that can be populated with task CPU processor blades, network processor blades, or any other blade designed for a specific application, and two slots for the system controller and switching blades. There are slot locations below the AdvancedTCA slots in the rear of the shelf for the two SAMs (shelf management alarm modules). All slots comply with PICMG 3.0 for power distribution and form factor and use the PICMG 3.1 for Ethernet and Dual Star interface. The shelf's other components include two Power Entry Modules (PEMs), one upper Fan Tray Module (FTM), one lower FTM, and front and rear cable management trays.

## 2.2 Platform Features

The AXP1440 includes the following features:

- 14-slot card cage with 14 rear transition module (RTM) slots
- Two Shelf Management Alarm Modules (SAMs)
- Up to two PICMG 3.0 compliant system controller and switching blades
- Two DC hot-swappable, 2N+1 redundant Power Entry Modules (PEMs)
- Fan Trays Modules (FTMs), one upper tray and one lower tray
- Front access service and installation of blades and lower fan tray
- Rear access service and installation of RTMs, SAMs, upper FTM, and PEMs
- Cable management, front and rear
- Alarm Display Panel (ADP) for telco alarms located on the front of the chassis
- Filler panels for front and rear slots

# AXP1440 Shelf Description

The following figure shows the location of each of the components in the AXP1440.

Figure 2-1 Front Shelf View

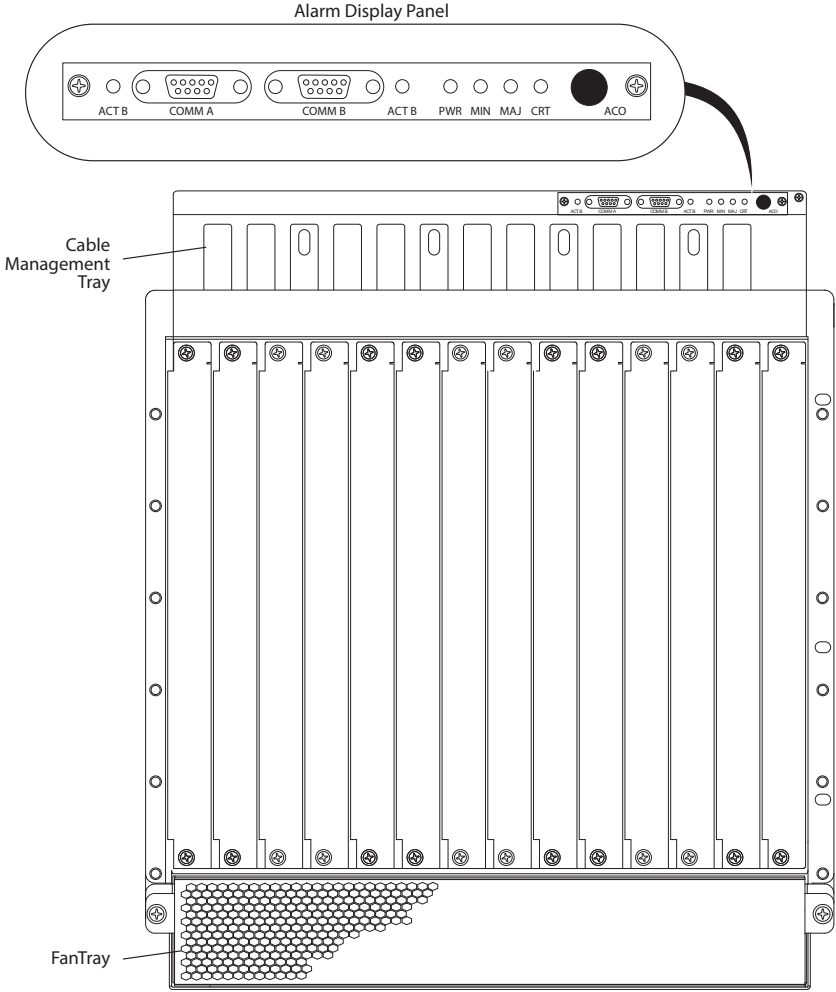
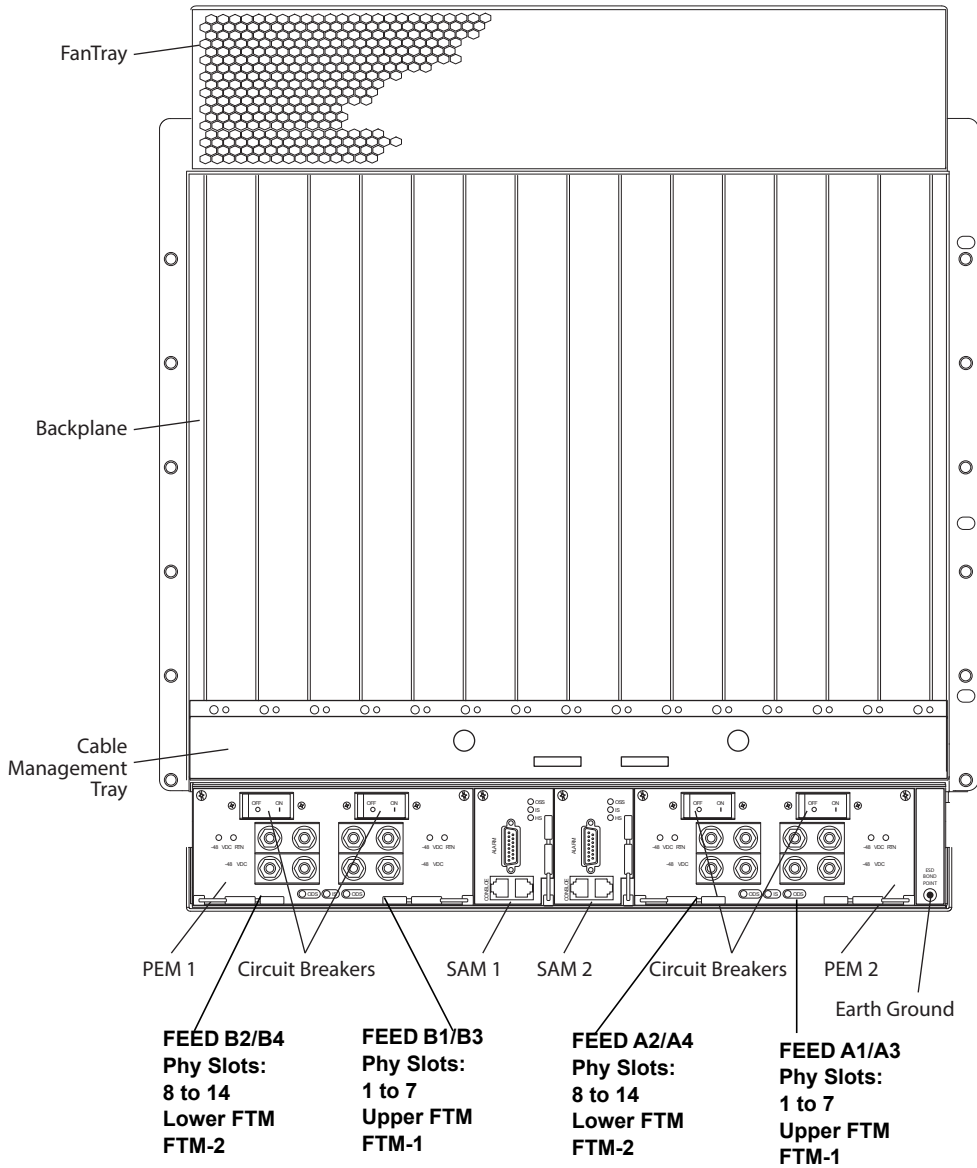



Figure 2-2 Rear Shelf View



### 2.3 Enclosure

The AXP1440 shelf consists of a formed 13U sheet metal card cage with structure and support for the backplane, PEMs, FTMs, SAMs, and 14 card slots. [Figure 2-1 on page 48](#) provides a front view of the shelf.

The enclosure mounts in a 600mm x 600mm ETSI frame relay rack or optional EIA 23" rack. Mounting holes for bezel brackets are provided, which allows the use of power supply or card cage (customer designed) bezels. See [Appendix A](#) for details on the physical characteristics of the enclosure.

### 2.4 Power Consumption

The following table shows the total power requirements for the shelf. Power consumption breakdown is also shown in the table.

Table 2-1 DC Shelf Power

FRU	Nominal Power (W) Shelf Only	Maximum Power (W) Shelf with Payload
PEM Subsystem	5	15
Fan Subsystem	100	1000
Shelf Management	6	20
ATCA Blades		4027.5
Total Shelf Power	111	5062.5

#### NOTICE

**Total maximum shelf power allocation is 5062.5W, defined in Shelf FRU Power Distribution Record. The ATCA blade Power Distribution record in shelf FRU is 350W.**

### 2.5 Shelf Ground Configuration

The AXP1440 shelf was tested in the default configuration of logic ground and shelf ground connected and does not connect -48VDC Return with Shelf Ground. The AXP1440 platform has been tested in the default configuration and complies with safety and regulatory standards.

As a compliant AdvancedTCA shelf, the AXP1440 allows system integrators, at their own discretion, to remove the mechanism which connects Logic Ground to Shelf Ground and install the mechanism that connects -48VDC Return to Shelf Ground. If the system integrator exercises the option of removing the connections from Logic Ground to Shelf Ground and or adds the connection between -48VDC Return and Shelf Ground, the responsibility for maintaining compliance to CSA (C/US)/VDE safety requirements and EMI/RFI emission limits rests entirely with the system integrator and installer.

## 2.6 Backplane

The shelf backplane supports two hub slots, 12 node slots, and two SAMs, and interfaces for clocking and metallic test bus. This AdvancedTCA backplane provides the IPMB and I<sup>2</sup>C bus interface signals from the shelf manager to all AdvancedTCA blades and the other FRUs. The backplane provides signal routing for fail-over signals between active SAM and standby SAM. The power connectors for the power entry modules are located on the backplane. The backplane is not a Field Replaceable Unit (FRU).

### 2.6.1 Functional Layout

The backplane provides dual star base interface and dual star fabric interface connections at each blade slot with segmented power (two power segments) provided by the dual Power Entry Modules (PEMs).

The blade slots are numbered physically from 1 to 14 going left to right along the front of the shelf. Numbers on slots 6 and 9 designate the hub slots. Each slot also has a logical slot number that defines it for backplane connectivity. Logical slot numbers are not shown on the shelf. The backplane functional layout is shown in the following figure.

# AXP1440 Shelf Description

Figure 2-3 Backplane Power Segments

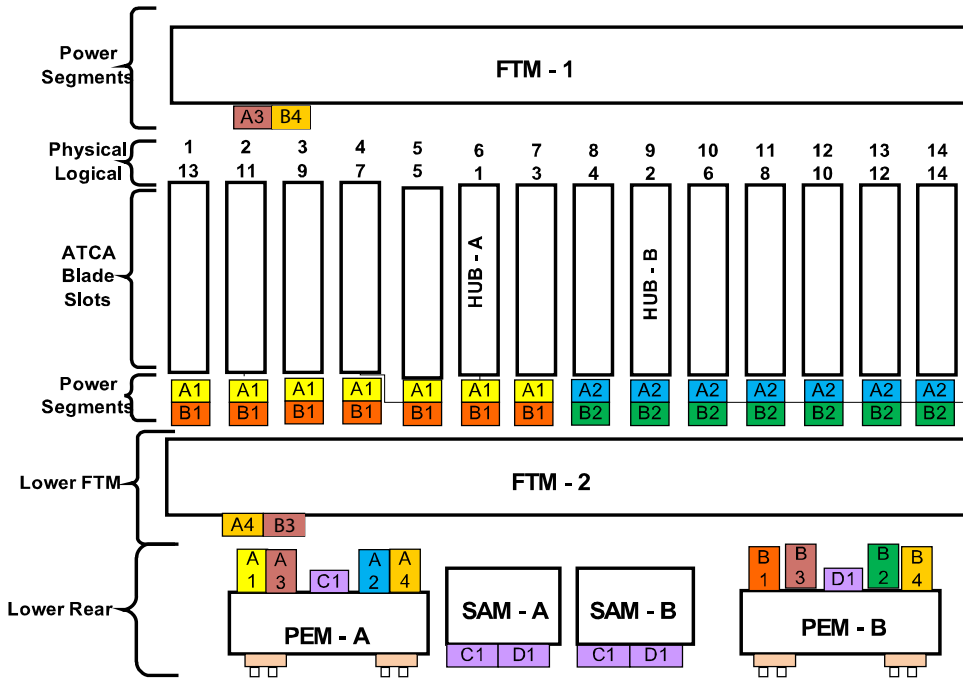

## 2.6.2 E-Keying

The AXP1440 supports the shelf management infrastructure with a process called E-Keying. E-Keying replaces the mechanical connector keying method used in earlier backplane designs. E-Keying prevents damage to blades, prevents mis-operation, and verifies fabric compatibility.

E-Keying entries are present as FRU information in the shelf FRU and all blades present in the shelf. The E-Keying entries describe the Base Interface, Fabric Interface, Update Channel Interface as well as the Synchronization Clock interfaces implemented by the shelf and blades. E-keying allows blades that support different PICMG 3 standards to be used in the same shelf.

More detailed information, such as connectivity and requirements for E-Keying can be found in PICMG 3.0 R1.0 AdvancedTCA Specification and the *AXP1440 Subsystem IPMI Programmer's Reference* listed in [Appendix A](#).

### 2.6.3 Shelf FRU Information

The SEEPROMs are located on the Alarm Display Panel (ADP); the FRU information for the PEM is contained in FRU 0. This information is accessed by using the standard IPMI FRU commands over the IPMC. Refer to the *AXP1440 Subsystem IPMI Programmer's Reference* listed in [Appendix A](#).

The SAM queries all IPMCs during system startup to determine whether they are a source of shelf FRU information and then uses that information to complete initialization. The information is cached as FRU 254 on the active ShMC (0x20). The information in the SEEPROM is only needed when the SAMs are first inserted or when the shelf is powered on for the first time. The redundancy feature provides the shelf-specific information should one SEEPROM be nonfunctional.

### 2.6.4 Backplane Slot Connectors

The following table provides a summary of what resides on each of the slot connectors.

Table 2-2 Slot Connector Description

Connector	Slots 6 and 9 (Physical) Switches	Slots 1-5, 7-8, 10-14 (Physical) Node
J10	Power, IPMB, Hardware Address	Power, IPMB, Hardware Address
P24	Base	N/A
P23	Fabric and Base	Base
P22	Fabric	N/A
P21	Fabric	N/A
P20	Update, Fabric	Update, Fabric

The following table provides connector-specific information for the backplane slots.

Table 2-3 Backplane Connectors

Zone	Connector	Where Used	Quantity
3			
2	P20	Slots 1 through 14	14
	P21	Slots 6 and 9	2
	P22	Slots 6 and 9	2
	P23	Slots 1 through 14	14

## AXP1440 Shelf Description

Table 2-3 Backplane Connectors (continued)

Zone	Connector	Where Used	Quantity
	P24	Slots 6 and 9	2
1	J10	Slots 1 through 14	14
N/A	SAM1_J1 and SAM2_J1	SAM A and B	2
	SAM1_J2 and SAM2_J2	SAM A and B	2
	PEM1_J1	PEM A and B	2
	FTM2_J1	Lower Fan	1
	FIB_J1	FTM Interconnect	1

Table 2-4 Slot Hardware Addressing for J10

Logical Slot	Physical Slot	HW Address	HA7	HA6	HA5	HA4	HA3	HA2	HA1	HA0
1	6	41h	Gnd	Open	Gnd	Gnd	Gnd	Gnd	Gnd	Open
2	9	42h	Gnd	Open	Gnd	Gnd	Gnd	Gnd	Open	Open
3	7	43h	Open	Open	Gnd	Gnd	Gnd	Gnd	Open	Gnd
4	8	44h	Gnd	Open	Gnd	Gnd	Gnd	Open	Gnd	Open
5	5	45h	Open	Open	Gnd	Gnd	Gnd	Open	Gnd	Gnd
6	10	46h	Open	Open	Gnd	Gnd	Gnd	Open	Open	Open
7	4	47h	Gnd	Open	Gnd	Gnd	Gnd	Open	Open	Gnd
8	11	48h	Gnd	Open	Gnd	Gnd	Open	Gnd	Gnd	Open
9	3	49h	Open	Open	Gnd	Gnd	Open	Gnd	Gnd	Gnd
10	12	4Ah	Open	Open	Gnd	Gnd	Open	Gnd	Open	Open
11	2	4Bh	Gnd	Open	Gnd	Gnd	Open	Gnd	Open	Gnd
12	13	4Ch	Open	Open	Gnd	Gnd	Open	Open	Gnd	Open
13	1	4Dh	Gnd	Open	Gnd	Gnd	Open	Open	Gnd	Gnd
14	14	4Eh	Gnd	Open	Gnd	Gnd	Open	Open	Open	Open

Table 2-5 Fan Tray Module Hardware Addressing

Physical Slot	HW Address	Site Type	HA7	HA6	HA5	HA4	HA3	HA2	HA1	HA0
Fan 1	1	04h					Gnd	Gnd	Gnd	Open
Fan 2	2	04h					Gnd	Gnd	Open	Gnd

Table 2-6 SAM and PEM Hardware Addressing

Physical Slot	HW Address	Site Type	HA7	HA6	HA5	HA4	HA3	HA2	HA1	HA0
PEM 1	1	01h							Gnd	Open
PEM 2	2	01h							Open	Gnd
SAM 1	1	03h							Gnd	Open
SAM 2	2	03h							Open	Gnd

## 2.6.5 Zone Locations on a Blade

The backplane provides dual star Base Interface and dual star Fabric Interface connections at each slot with segmented power (four power segments) provided by the dual PEMs.

- Zone 1 provides the system management and power interfaces, such as redundant -48VDC power and IPMB
- Zone 2, the data transport interface, provides the Base and Fabric interfaces, and Update Channels through the ZD connectors per front-side blade
- Zone 3 provides the direct interconnect for user designated I/O

### NOTICE

**Rear Transition Modules connect directly with the connectors on the front-side blade and do not make the connection through the backplane.**

# AXP1440 Shelf Description

Figure 2-4 Base and Fabric Interface Connectivity

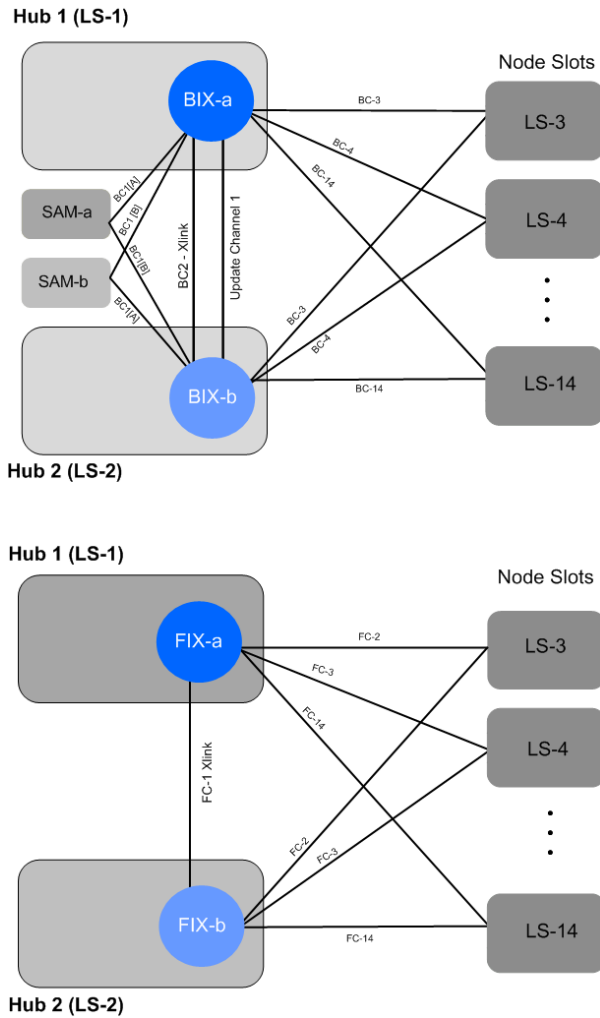

## 2.7 IEEE802.3ap/IEEE802.3ba

The AXP1440 backplane is designed to support 10 G and 40 G traffic through 10GBASE and 10GBASE-KR4.



## 2.8 Fan Tray Modules (FTMs)

The AXP1440 supports two fan trays in a push/pull configuration. Each fan tray contains six dual counter rotating fans. The lower fan tray is accessible from the front of the chassis and contains the replaceable air filter. The upper fan tray is located in the rear of the chassis.

The FTM has a ejector handle which signals the IPM Sentry software for hot swap. If your system is not running high-availability software, behavior of the LED may be indeterminate. The face plate of the upper and lower FTMs has the following indicators:

Table 2-7 FTM LED Status Indicators

FTM LED	LED Color	State/Condition
In-Service (IS)	Green	Off: no service Blink: FTM activating Glow Steady: service available
Out-of-Service (OOS) and Failure	Red (default)	Off: service available Blink: Deactivation requested Glow Steady: no service
Hot Swap (H/S)	Blue	Off: FTM is not ready to be removed Blink: Deactivation requested Glow Steady: FTM is ready to remove

Figure 2-5 Lower Fan Tray Module, Front View

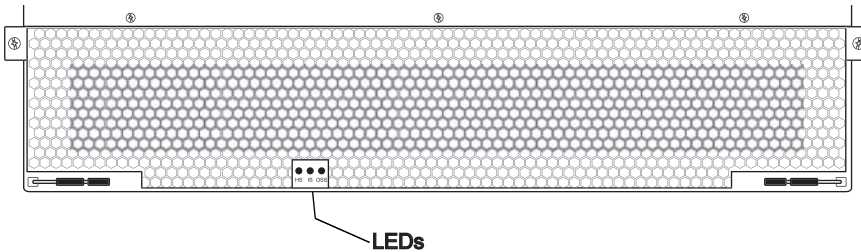
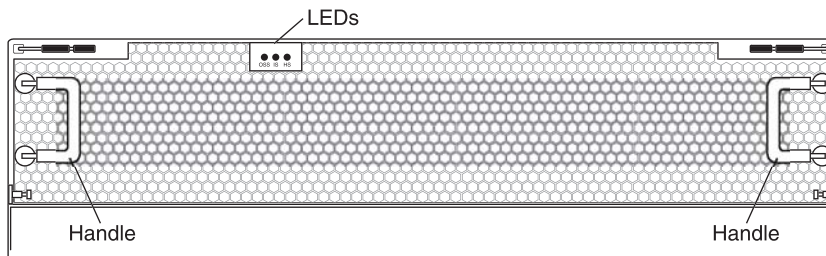

Figure 2-6 Upper Front FTM, Front View



## 2.9 Power Entry Modules (PEMs)

The PEM is a Field Replaceable Unit (FRU) and can be replaced while the system is on, but the power for the PEM being replaced (PEM A or PEM B) must be shut down at the external source. Replacement can take place in under 30 minutes by a trained service person.

For important information on removing power before replacing a PEM, refer to [Recommended Power-Off Procedures on page 75](#) and [Power Entry Module \(PEM\) on page 76](#).

The PEMs are accessible from the rear of the shelf and connect to the power entry module connectors on the backplane. A removable plastic housing covers the power feeds and returns to prevent accidental shorting. The PEM also features an injector/ejector handle that provides the hot swap mechanism for signaling the state of the PEM prior to removal.

Each PEM powers two separate power domains A and B and each domain supports two 80A power rails to supply power to the AdvancedTCA slots.

The PEMs are hot-swappable and will not cause a fault when one is removed for replacement. Two PEMs are required to support 2N+1 redundancy. If your system is configured for redundant operation using two power feeds, they operate in load sharing where the total load is equal to or less than what one power feed can provide.

Figure 2-7 PEM Backplane Connectivity

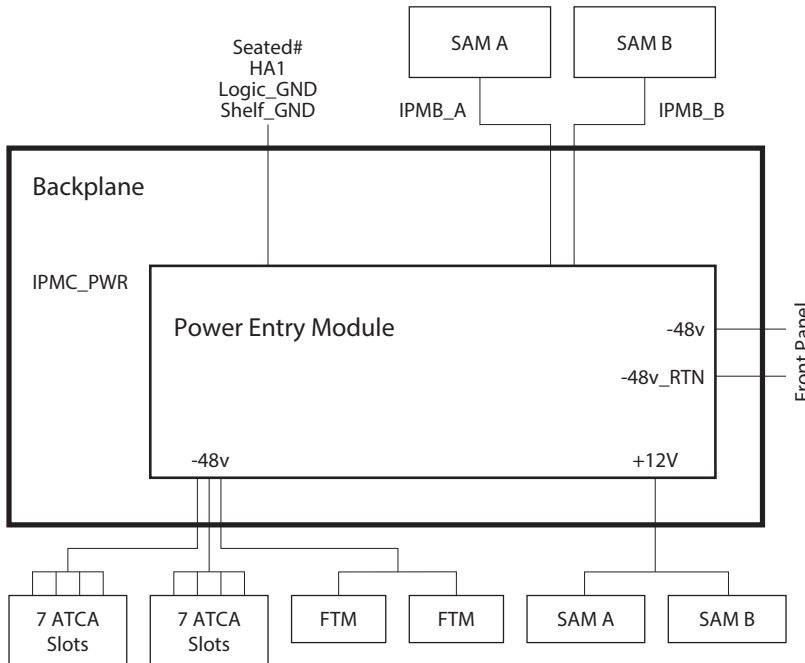

Each of the PEMS are equipped with two rocker type circuit breakers, three status LEDs, hot swap ejector handle, and a plastic cover that protects the dual stud terminal block. The rear of the PEM has two output connectors that mate with the backplane.

Figure 2-8 PEM View with Detail

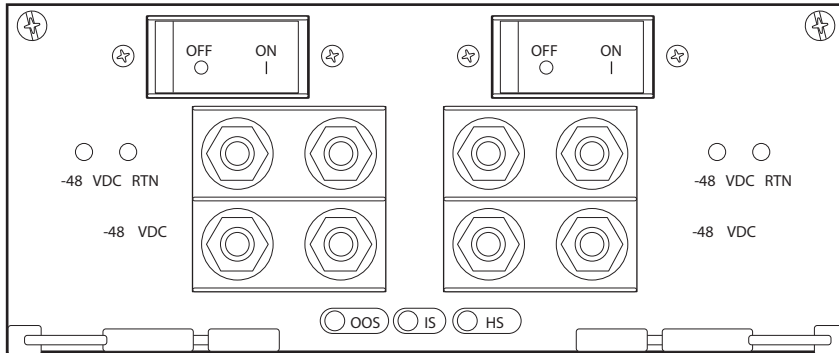

Table 2-8 PEM LED Status Indicators

Power LED	Color	State/Condition
In Service	Green	Off: no service Blink: PEM activating Glow Steady: service available
Out of Service (OOS)	Red	Off: service available Blink: Deactivation requested Glow Steady: no service
Hot Swap (HS)	Blue	Off: PEM is not ready to be removed Blink: Deactivation requested Glow Steady: PEM is ready to remove

## 2.10 Stationary Boards

There are four stationary boards in the shelf which are completely passive and are not field replaceable:

- Backplane
- Upper Fan Interconnect board, provides power and signaling from the backplane to the FTM distribution board
- FTM distribution board, provides the signal and power connections to the upper fan tray modules from the backplane

## AXP1440 Shelf Description

- Alarm Display Panel (ADP), contains the shelf FRU SEEPROMs, telco alarm indicators, and serial console ports for the SAM. The following table shows the ADP telco alarm indicators:

Table 2-9 ADP LED Status Indicators

Alarm Display Panel LED	LED Color	State	State/Condition
Critical alarm (CRT)	Red	On	Active
Major alarm (MAJ)	Red	On	Active
Minor Alarm (MIN)	Yellow	On	Active
Power (PWR)	Green	On	Power Present

## 2.11 Standard Compliances

The AXP1440 AdvancedTCA platform complies with the safety and regulatory standards as shipped from the factory. It is possible to use this product with other components that produce a system not in compliance with system guidelines. Since Penguin Solutions cannot anticipate what equipment may be used with this enclosure or how it may be used, the responsibility for designing a system that conforms overall to the safety requirements, EMI/RFI emission limits, and other applicable standards rests entirely with the system integrator and installer.

Table 2-10 Standard Compliances

Standard	Description
PICMG3.0 R1.0 PICMC1.5.1	Defines mechanics, board dimensions, power distribution, power and data connectors, and system management.
UL 62368-1, EN 62368-1 IEC 62368-1 CAN/CSA C22.2 No 62368-1	Safety Requirements (legal)
CISPR 22, CISPR 24 EN 55022, EN 300386 FCC Part 15 Industry Canada ICES-003	EMC requirements (legal) on system level (predefined Penguin Edge™ system)

Table 2-10 Standard Compliances (continued)

Standard	Description
NEBS Standard GR-63-CORE NEBS Standard GR-1089-CORE ETSI EN 300 019 series ETSI ETS 300 753	Environmental Requirements
ETSI EN 300 132-2	Power requirements
Directive 2011/65/EU	The product has been designed to meet the directive on the Restriction of the use of certain Hazardous Substances in electrical and electronic equipment (RoHS).



To fulfill the requirements of Telcordia GR-1089, R4-14, use Shielded Twisted Pair (STP) cables grounded at both ends to connect to the Ethernet ports.

## 2.12 WEEE Compliance



To satisfy the requirements for marking electrical and electronic equipment in accordance with article 11 (2) of Directive 2002/96/EC, Waste from Electrical and Electronic Equipment (WEEE), Penguin Solutions includes a crossed-out bin symbol on all standard and non custom chassis product. This marking fulfills the requirement set out by WEEE that a producer of an electrical or electronic appliance that bears their trade name and is put on the European Union market after 13 August 2005, places a clearly identifiable mark on the equipment and that this mark signifies that equipment is to be reprocessed or recycled using authorized recyclers and processes. This minimizes the disposal of unsorted municipal waste, achieves a high level of separate collection of WEEE, and ensures the environmentally sound disposal of electrical and electronic equipment placed on the market after 13 August 2005.

To dispose of equipment marked with the WEEE symbol, Penguin Solutions has contracted with certified companies that can reprocess this equipment per European Union requirements. Please visit the Penguin Solutions web site or contact your Penguin Solutions representative to find out who to contact and how to dispose of the equipment.

## AXP1440 Shelf Description

---

# Site Preparation

## 3.1 Overview

The following sections help you to prepare system installation. It provides information on unpacking and inspecting the system, requirements, technical data, and additional information you need to know before you begin system installation. At the end of the chapter there are helpful checklists for preparing your site for the installation.

## 3.2 Site Planning Considerations

This section provides information to prepare the site and the shelf for installation.

### 3.2.1 Receiving and Unpacking the System

Carefully inspect the system and all components delivered together with it.



#### Personal Injury

The system is heavy and if you carry it on your own you can hurt your back. To prevent injury, keep your back straight and have two people lift the system or use additional lifting equipment.



#### System Damage

Unstable system installation in a rack can cause the rack to topple over. Therefore, if your system is the only one in the rack, make sure to mount the system in the lowest part of the rack. If other systems are installed in one rack, start with the heaviest component at the bottom. If the rack is equipped with stabilizing devices, make sure that they are installed and extended so that the rack is secure. Then proceed to mount or service the system. Do not tilt the system forward or backward when removing it from the system package as the FRU ejector handles at the bottom could be damaged.

Use ESD protection



#### Damage of Circuits

Electrostatic discharge and incorrect RTM installation and removal can damage circuits or shorten their life. Before touching the RTM or electronic components, make sure that you are working in an ESD-safe environment.

## Site Preparation

---

### Shipment Inspection

To inspect the shipment perform the following steps:

1. Verify that you have received all items of your shipment.
2. Compare the shipment thoroughly with the delivery note.
3. Visually inspect the shelf to ensure that all of the connector pins are straight, shrouds are properly seated, screws are tight, and so on.
4. Check the rails for proper alignment.
5. Check that the air filter is properly installed.
6. Check that the cable connections are secure and properly fitted.
7. Check the EMI gaskets for damage.
8. Check the items listed above for damage and report any damage or differences to the customer service at <https://www.penguinsolutions.com/edge/support/>.
9. Tighten loose screws before proceeding.
10. Remove the desiccant bags delivered together with the system and dispose of them according to your country's legislation.
11. Do not remove shipping frame stiffeners until positioning is complete and all bolts are fully tightened. Mounting without frame stiffeners may cause warping of the chassis.



**The system is thoroughly inspected before shipment. If any damage occurred during transportation or any items are missing, please contact our customer's service immediately.**

### 3.2.2 Site and Installation Planning

Planning basic site and installation requirements you have to consider the following issues:

- Is adequate power for the AXP1440 system available?
- Can the system be positioned in a way that -48 to -60V DC power source is easy to reach?
- Are racks with sufficient space to install the system available?
- Is suitable equipment available to lift the system into the rack?
- Is there enough space to run a system console terminal? Is the cable long enough to reach the system?
- Are the inlet and outlet of the fans and therefore the airflow not blocked?



### 3.2.3 Requirements

Before and during system installation and operation, you always have to ensure that the requirements listed in the following sections are met.

#### 3.2.3.1 Environmental Requirements

To ensure proper function of the system, make sure that the environment in which the system is to be used fulfills the environmental requirements.

The environmental values must be tested and proven in the planned system configuration, that is, the delivered system and other third-party products you want to integrate.

**NOTES:** Operating temperatures refer to the temperature of the air circulating at the air intake of the system and not to component temperatures.

Some of the climatic values may exceed the specification of some system components (for example, hard disks). As Penguin Solutions cannot guarantee the functionality of third party products that are handled or operated out of their specifications, the environmental conditions may be limited to the specifications of these components.

The following table lists the environmental requirements.

Table 3-1 Environmental Conditions

Feature	Operating	Non-Operating (packed state)
Temperature	+5°C (41°F) to +40°C (104°F) (normal operation) according to NEBS standard GR-63-CORE -5°C (23°F) to +55°C (131°F) (exceptional operation) according to NEBS standard GR-63-CORE	-40°C (-40°F) to +70°C (158°F)
Temp. change	±0.25°C/min according to NEBS standard GR-63-CORE	±0.25°C/min
Relative humidity	5% to 90% non-condensing according to Penguin Edge-internal environmental requirements	5% to 95% non-condensing according to Penguin Edge-internal environmental requirements
Shock	Half-sine, 11ms, 30m/s <sup>2</sup>	Blade level packaging Half-sine, 6ms at 180m/s <sup>2</sup>

# Site Preparation

Table 3-1 Environmental Conditions (continued)

Feature	Operating	Non-Operating (packed state)
Vibration (tested in target platform)	0.1g from 5Hz to 100Hz and back to 5Hz at a rate of 0.1 octave/minute	5-20Hz at 0.01g <sup>2</sup> /Hz 20-200Hz at -3.0 dB/octave Random 5-20Hz at 1m <sup>2</sup> /s <sup>3</sup> Random 20-200Hz at -3 dB/octave
Free fall	-	300mm (11.8 in) (packaged) 25mm (1 in) (unpacked) per GR-63-CORE fully populated system
Noise	<p>ETSI ETS 300 753 (October 1997) Telecommunication equipment rooms (attended): 7.2 bel Measurement of declared A-weight sound power level All values are applicable to normal operating conditions (~23°C).</p> <p>NEBS GR-63-CORE, Issue 3 Telecommunication equipment rooms (attended): 78 dB Measurement of declared A-weight sound power level All values are applicable to normal operating conditions (~27°C).</p>	-

The ambient temperature around the shelf and the air inlet temperature must not exceed 55°C (131°F).

The AXP1440 system regulates the fan speed based on the temperature sensors present in the system. The fan speed is adjusted to the lowest speed which still keeps the evaluated temperature readings below or at their respective upper non-critical threshold. Hence, the fan speed depends on the ambient temperature, blade design, temperature threshold settings, and system configuration.

To guarantee proper blade operation, make sure that the temperatures at the locations specified in the following are not exceeded. If not stated otherwise, the temperatures should be measured by placing a sensor exactly at the given locations.

*Table 3-2 Critical Temperature Limits*

Component	Temperature Limit
Air inlet (system's front)	55°C (131°F)
Air outlet (system's rear)	70°C (158°F)
Power entry module lug-plastic washer	<p>70°C (158°F)</p> <p>&gt;70°C (158°F) and maximum 90°C (194°F): the cables must be isolated and must be approved to be used in this temperature range.</p> <p>&gt;70°C (158°F) and maximum 90° (194°F): the service personnel may touch the components: the cables must be isolated and the hot surface icon must be attached. The cables must be approved to be used in this temperature range.</p> <div style="text-align: center;">  </div>

### 3.2.3.2 Power Requirements

Make sure that a suitable -48VDC or -60VDC power source is within reach of the system. Two power entry modules (PEMs) can be installed in the system. The shelf may require up to 125 amps DC, through two 80 amp feeds. The required cable size for 80 amps is 4 AWG wire.

	<p><b>Personal or System Damage</b></p> <p><b>The system may be supplied by a TNV-2 voltage. This voltage is considered hazardous.</b></p> <p><b>Make sure that the power supply unit meets the local safety standards.</b></p>
---	---

*Table 3-3 System Power Requirements*

Feature	Value
Rated voltage Input current	<p>-40VDC to -60VDC (SELV)</p> <p>-60VDC to -72VDC (TNV-2)</p> <p>125A</p>

## Site Preparation

Table 3-3 System Power Requirements (continued)

Feature	Value
Operating voltage range	-40.0 to -72VDC



**When installing additional blades or modules, make sure that the power consumption of all installed modules does not exceed the system's maximum power dissipation.**

### 3.2.4 Dimensions and Weight

The table below lists the dimensions and weight of the shelf and system components.

Table 3-4 Dimensions and Weight of System and Components

Component	Dimensions w x h x d in mm (inches)	Weight in kg (lbs)
Shelf, including two fans, two PEMs, air filter	497 x 573 x 544 (19.6 x 22.6 x 21.4)	39.7 (87.5)
PEM	164 x 73 x 155 (6.5 x 2.9 x 6.1)	1.7 (3.7)
Upper Fan Tray Module	491 x 87 x 227 (19.3 x 3.4 x 8.9)	4 (8.8)
Lower Fan Tray Module	491 x 119 x 331 (19.3 x 4.7 x 13.0)	6.1 (13.4)
ATCA-F120	30 x 351 x 312 (1.2 x 13.8 x 12.3)	2.8 (6.16)
ATCA-F120-RTM	322 x 70 (12.7 x 2.8)	0.7 (1.54)

### 3.2.5 Mounting Options

You can operate the system on your desk or you can install it in a standard 23" rack.

During installation of the system, make sure to follow these guidelines:

- During the course of handling, shipping, and assembly, check that pins, shrouds and mounting screws, fans, and other items are not loose or damaged.
- Do not operate a damaged shelf, this can cause damage to devices that interfere with it.

- Do not remove shipping frame stiffeners until positioning is complete and all bolts are fully tightened. Mounting without frame stiffeners may cause warping of the chassis.
- Always lift the chassis from the bottom/base of the chassis.
- Do not lift chassis at the internal card cage.
- Lifting at internal card cage may cause warping of the chassis and prevent proper insertion of blades products.
- Do not lift chassis at the front upper fan tray or top front of chassis.
- Lifting at these points may cause warping of the chassis and prevent proper EMI sealing or damage to the fan tray.

### 3.2.6 Grounding

To ensure the system is properly grounded, each of the system's parts contact the EMI gasket. The system contains gaskets at the shelf and module level.

<p><b>Use ESD protection</b></p> 	<p><b>The shelf is also fitted with ESD contacts. Please use proper ESD protection.</b></p>
--	---

### 3.2.7 Rack Mount Dimensions

You have to keep in mind the following conditions when installing the system into a 600mm (23.62") deep rack. The physical dimensions in the figure below are in millimeters.

Figure 3-1 Rack Mounting Dimensions

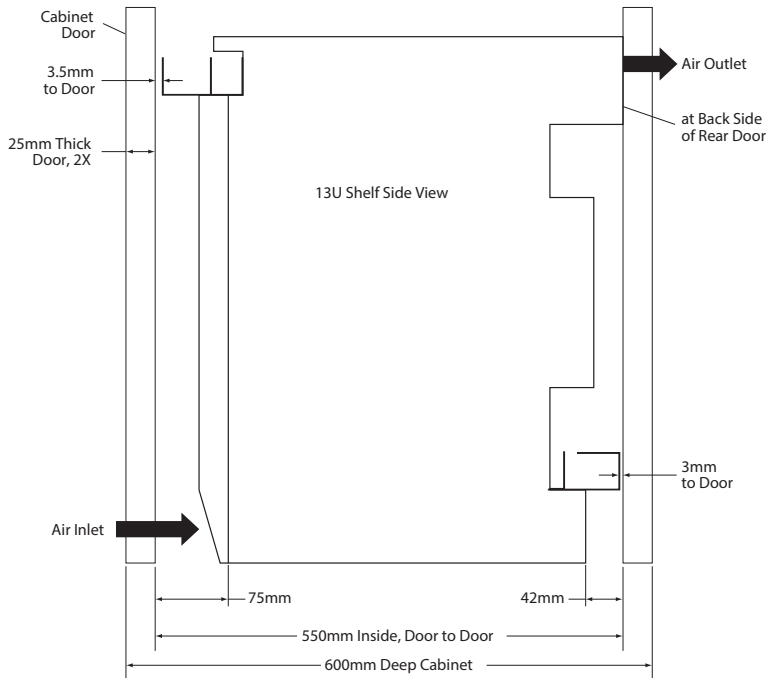

## 3.2.8 Airflow Requirements

The AXP1440 provides fault tolerant cooling to front-mounted AdvancedTCA blades and to rear transition modules based on one front and one rear maintainable intelligent fan trays with six fans per tray.

Fan trays are mounted in the shelf top and bottom. The figure below shows the general airflow for the system.

Figure 3-2 Shelf Airflow

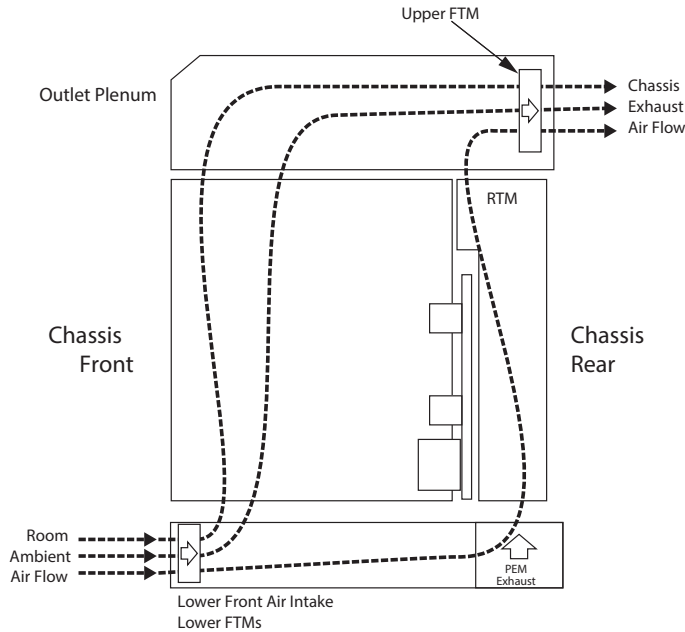

**NOTES:**The cooling subsystem is compliant to CP-TA B.4. The cooling system provides for greater than 40 CFM for the front blade and 5.0 CFM for the RTM.

The actual cooling performance depends on the slot population and the heat sink design of installed blades and should be validated based on the used configuration.

The distance to other equipment must be sufficient to avoid an overheating of the system.

The cooling subsystem is designed to provide 31.1 CFM in the front and presence of any single cooling failure.

## 3.2.9 Acoustic Noise Control

The system can generate a lot of acoustic noise. This system has a built-in noise control due to the fan speed control. If the system is installed in an environment where the noise may be harmful to personnel being exposed to the noise during extended time periods, additional protective measures should be considered.

### 3.3 Site Planning Checklists

The following table lists the tasks which you have to perform as plan the installation of the system.

*Figure 3-3 Planning Checklist 1*

- |   |                          |
|---|--------------------------|
| Determine where to install the system and ensure that the required installation tools and equipment are available | <input type="checkbox"/> |
| Control the available installation tools and equipment  | <input type="checkbox"/> |
| Ensure that enough space is available   | <input type="checkbox"/> |
| Determine the needed power  | <input type="checkbox"/> |
| Plan the cable management   | <input type="checkbox"/> |
| Ensure proper cooling   | <input type="checkbox"/> |
| Schedule the arrival of system  | <input type="checkbox"/> |
| Consider consulting of Artesyn services   | <input type="checkbox"/> |



Figure 3-4 Planning Checklist 2

Issue	Entry
General site review	
Order number	
Schedules shipping date	
Installation date	
Site address	
Company name	
Special Instructions	
Operational days	
Contact data	
Contact name	
Phone number	
Fax number	
Email Address	
Site Constructions	
What floor?	
Path to the installation area clear?	
Freight elevator available?	
How many shelves must be installed?	
Enough space available?	
DC or AC available?	
All required cables available?	



# AXP1440 Operations

---

## 4.1 Overview

This chapter provides the basic operating procedures for the AXP1440. For software-specific information, or information regarding the operation of third-party or add-on components, please refer to the software or hardware product's vendor documentation. You can refer to [Appendix A](#) for a collection of supporting manuals.

This chapter covers the following topics:

- [Recommended Power-On Procedures](#)
- [Recommended Power-Off Procedures](#)
- [Emergency Power-Off Procedures](#)
- [Power Entry Module \(PEM\)](#)
- [Fan Tray Modules](#)
- [Air Filter Maintenance](#)
- [Cleaning the Air Filter](#)

## 4.2 Recommended Power-On Procedures

### Procedure - Power-On System

Follow these steps to power-on your AXP1440.

1. Verify that all shelf modules and associated data and control cables are properly configured and installed. Make sure that all empty or unused slots contain an approved filler panel.
2. Enable DC power at each external source (branch circuit or power distribution unit).
3. Push the circuit breakers to the ON position. They are located on the front of each PEM.

## 4.3 Recommended Power-Off Procedures



**Step 2 removes the input power from the slots in the AXP1440 shelf only. It does not remove power to the PEMs. To remove power to these components, refer to the next step.**

### Procedure - Power-Off System

Follow these steps to shut down your AXP1440.

1. Shut down all software operations and the operating system. For shelves with independently running segments, each segment must be shut down.
2. Turn each circuit breaker on the front of PEM A and PEM B to the OFF position.
3. Disable the DC power at each of the external sources (branch circuit or power distribution unit) for both PEM A and PEM B.

This completely removes power from the shelf and its subassemblies.

## 4.4 Emergency Power-Off Procedures



**Following this procedure will result in a loss of data and may cause damage to chassis components in a running platform. Use this method only when normal shutdown procedures cannot be followed.**

### Procedure - Emergency Power-Off

Read the caution and follow the next steps if it is necessary to remove power during an emergency situation.

1. Turn each circuit breaker on the front of PEM A and PEM B to the OFF position.
2. Disable the DC power at the external sources (branch circuit or power distribution unit) for PEM A and PEM B).

## 4.5 Power Entry Module (PEM)

This section discusses the operations of the Power Entry Module for the AXP1440 configurations.

### 4.5.1 Description

The AXP1440 has PICMG 3.0 compliant, dual PEMs and is rated for nominal -48 VDC to -60 VDC. The PEMs plug directly into the mid plane and deliver power to the backplane. Each input is rated for 80A. The two 80A feeds each power eight AdvancedTCA slots and the upper and lower FTMs. Each PEM also generates a separate +12V for redundant powering of the SAMs. This voltage is distributed to each of these modules across the backplane.

Power conversion for the SAMs and PEMs consists of two 66W, +48VDC to +12VDC converters which distribute dual power busses of +12VDC to separate parts of the system. The +12VDC outputs are provided on the backplane connector to the rest of the shelf. Power is redundant through the secondary PEM



**Removing power to these components cannot be accomplished by turning the PEM's circuit breakers to the OFF position. The PEMs remain powered until the -48 VDC power to each PEM is removed. Make sure you disconnect the power at the external source before removing the PEM from the shelf.**

Power is introduced to the PEM using a DC power cable attached to the terminal blocks on the front of the module (power input cable and return cable). The terminal block consists of a dual stud connection which prevents the power cables from rotating and provides secure contacts for the cable lug. There is a plastic cover that protects the cable connections.

### NOTICE

**The DC power inputs must only be attached to approved Telephone Network Voltage (TNV) or Safety Extra Low Voltage (SELV) branch circuits. Branch circuits must comply with all requirements called for in these safety standards: IEC 62368-1, EN 62368-1, CAN/CSA-C22.2 No. 62368-1. Attaching inputs to non-TNV/SELV approved power sources will cause the system to fail compliance with safety regulations.**

## 4.5.2 IPMC Circuitry

Each PEM is capable of monitoring voltage and circuit breaker status. The PEMs are loaded with the AdvancedTCA IPMC firmware. Preprogrammed FRU and Sensor Data Record (SDR) information reside on the PEM and is accessible from the SAM through the IPMB ports of the PEM. In addition, the IPMC monitoring functions include digital inputs to detect circuit breaker trips, voltage sensors to detect backplane voltages, current sensors to detect current to the backplane, and on-board circuitry to detect failures on the PEM. The PEMs are managed by the Sentry Shelf Management software. Refer to the *AXP1440 Subsystem IPMI Programmer's Reference* guide listed in [Appendix A](#) for more information.

Table 4-1 PEM IPMB Addresses

Description	IPMB Address
PEM A	0x66
PEM B	0x68

*Figure 2-3 on page 52* provides a conceptual view of the connections between the PEMs, backplane, FTMs, and SAMs.

# 4.6 Fan Tray Modules

This section discusses the operation of the Fan Tray Modules (FTMs) of the AXP1440.

## 4.6.1 Description

The FTMs are loaded with AdvancedTCA IPMC firmware. The fans are controlled as a group through the IPMI-based interfaces (IPMB) to the SAM. The IPMI interface is used for reporting faults, events, and status. The shelf manager software performs management of the FTM through the IPMB bus. The IPMC circuit provides temperature sensors for monitoring the temperatures of the FTM board components and for monitoring the inlet and outlet air temperature of the shelf. For further information, refer to the *AXP1440 Subsystem IPMI Programmer's Reference* guide listed in [Appendix A](#).

The upper FTM receives its signal and power connections from the backplane through a FTM distribution board. A fan interconnect board connects the backplane to the FTM distribution board. The FTMs are powered from -48 VDC from the backplane. The lower FTM receives its signal and power connections from the AdvancedTCA backplane. Only the lower FTM has an air filter frame and filter in the module.

The FTMs have variable speed fan control, which is dependent on the temperature readings in the shelf. Airflow rates can vary depending on the fan speed and payload. Fan speed levels are controlled from the SAM through the IPM shelf management software. The fan speed levels change automatically based on temperature sensors. For more information, refer to [Fan Speed and Control on page 126](#).

The FTMs have an ejector handle that interfaces with a mechanical switch to signal the software for hot swap. The handle and captive screws lock the FTM securely into the shelf. Each FTM is equipped with three status LEDs on the face plate. For removal and installation procedures for the FTMs, refer to [Chapter 6](#).

In the event of a Fan/Filter Out-of-Service alarm, first check the fan filters (only on the lower FTMs) to make sure the airflow is not obstructed. For information on the maintenance of air filters, see [Air Filter Maintenance on page 79](#).

## 4.6.2 Cooling Budget

The shelf cooling is designed to operate with the following temperature rises across the shelf. This allows cards with these dissipations to operate with commercial grade components, 70°C ambient temperature typical.

Table 4-2 Cooling Budget

Ambient Temperature	Temperature Rise
25°C	Delta T = 20°C
40°C	Delta T = 15°C
55°C	Delta T = 10°C

The following guidelines can assist in determining the cause of the cooling failure. Also refer to [Environmental Requirements on page 65](#) for important information regarding ambient temperature requirements during servicing.

If a cooling failure occurs, the failure may be caused by a failed fan or possibly a clogged filter. Check the filter first before replacing the FTM, see [Air Filter Maintenance on page 79](#).

For further information of nonrecoverable temperature events, refer to the FRU Information chapter in the *AXP1440 Subsystem IPMI Programmer's Reference*.

### 4.6.3 IPMC Circuitry

Preprogrammed FRU and SDR information reside on the FTMs and is accessible from the SAM through the I<sup>2</sup>C bus. FRU information can be found in the *AXP1440 Subsystem IPMI Programmer's Reference*, listed in [Appendix A](#).

## 4.7 Air Filter Maintenance

Air filters should be cleaned every 90 days or sooner, depending on the conditions of the Central Office Environment. Because Central Offices vary in physical location and cleanliness, check your air filters every week after you first install your system. In a dusty environment, a filter may need cleaning more often than a filter in a cleaner environment. Check the filters frequently until you have a good idea of how often it needs cleaning. Based on your findings, establish a regular cleaning schedule and keep a log to record the date of each filter cleaning or replacement.

Air filters should also be checked occasionally to make sure they are not obstructed or damaged. Visually inspect filters for tears or rips. Do not reinstall a torn filter as it will be ineffective in trapping particulates and will interrupt air flow distribution. To maintain safety certification, use only Penguin Solutions approved fan filters. You can order replacement fan filters (part number RAF1440) by contacting your Penguin Solutions sales representative.

For replacement procedures, refer to [Replacing the Fan Filter on page 117](#).

### 4.8 Cleaning the Air Filter

To make sure the AXP1440 shelf operates properly, routine filter maintenance is required as discussed in [Air Filter Maintenance on page 79](#). Maintenance includes cleaning, replacing, and properly storing the air filters.

Filter cleaning frequency depends on the environment the system is subjected to. The shelf filter requires routine cleaning to ensure effective filtration and airflow. To prevent air contamination from polluting the air filter and possibly obstructing the air intake of the system, the air filter should be replaced according to the schedule you have established based on your Central Office Environment as discussed in [Air Filter Maintenance on page 79](#).

Remove and inspect the filter for tears or damage before cleaning it. If the filter is torn or damaged, discard the filter and replace it with a new one. Refer to [Replacing the Fan Filter on page 117](#) if you need help.

If the filter is undamaged, proceed to clean it. There are several methods for cleaning the air filter.

- Vacuum clean. A few passes of a vacuum cleaner can remove accumulated dust and dirt.
- Oil-free compressor air. Point the compressed air nozzle in the opposite direction of the filter's operating airflow (blow from the filter's exhaust side toward the intake side).
- Cold water rinse. Collected dirt is washed away using a standard hose nozzle with plain water. Ensure the filter is completely dry before returning to service.
- Immersion in warm soapy water. Dip the filter in a solution of warm water and mild detergent. Then rinse the filter in clear water and let stand until completely dry before returning to service.



**Before returning a filter to service, visually inspect it for tears or rips that may have occurred during cleaning. Do not reinstall a torn filter as it will be ineffective in trapping particulates and will interrupt air flow distribution. You may order replacement fan filters (part number RAF1440) by contacting your Penguin Solutions sales representative.**

#### 4.8.1 Storing the Filter

The ideal storage condition for the air filter is a cool, dry, dark environment. High temperature, humidity, and ultraviolet light adversely affect the filter media (foam). Foam also degrades when exposed to solvents and sulfates, such as engine exhaust.



Controlling relative humidity between 40%-80% and temperature between 4.4°C - 32.2°C (40°F - 90°F) yields an acceptable environment. Covering the filters with dark plastic keeps the foam dry and protects it from ultraviolet light. Purchase enough to keep adequate inventory for no more than a few months, filters could degrade under long term storage conditions.



# AXP1440 Shelf Installation

## 5.1 Overview

This chapter discusses mounting and installation options for the AXP1440 shelf.

The following are the topics covered in this chapter:

- [Installation Prerequisites](#)
- [Installing the Shelf](#)
- [DC Power Cable](#)
- [Connecting the Cables to the PEM](#)
- [Grounding the Shelf](#)
- [Shelf Ground Configuration](#)
- [Powering Up the System](#)
- [Accessing the System](#)
- [Upgrading Firmware](#)

## 5.2 Shelf Physical Characteristics

The following table provides the dimensions and weight of an equipped and unequipped shelf and rack mounting requirements.

Table 5-1 AXP1440 14-Slot Shelf Physical Characteristics

Characteristics	Specifications
Size	22.56 inches (57.3 cm) high, 13U 17.67 inches (44.88 cm) wide 21.06 inches (53.5 cm) with mounting flanges 21.51 inches (54.64 cm) deep with cable trays
Weight	Approximately 87.5 lbs (31.5 kg) base integrated platform Base platform: 2 shelf managers, 2 PEMs, 1 upper FTM, 1 lower FTM (no payload blades)

## AXP1440 Shelf Installation

---

Table 5-1 AXP1440 14-Slot Shelf Physical Characteristics (continued)

Characteristics	Specifications
Rack Mounting	<p>Per ETSI 600 mm x 600 mm ETSI frame on integrated front frame mounting ears.</p> <p>Frame mounting brackets are required for a 23" EIA frame. Rear mounting brackets are recommended in both instances for Central Office Environment.</p> <p>Each shelf requires 13 U of space and effectively takes up 13 U when mounted in a rack. Three shelves can fit in a 40U telecom rack, which leaves 1U remaining.</p> <p>Cable management trays are available for the front and the rear of the shelf.</p>

## 5.3 Installation Prerequisites

This section describes the prerequisites required for installation.

### 5.3.1 Equipment You Will Need

You need the following to install the AXP1440 14-slot shelf into an approved EIA 23" or 600mm x 600mm ETSI frame:

- Torque wrench
- Nut driver with 7/16 mm socket
- Multimeter
- Phillips head screwdriver, #1
- Front mounting brackets for an EIA 23" frame (shipped with your AXP1440)
- AdvancedTCA PEM Service Kit, PN 6706808A01 (shipped with your AXP1440)
- Right-angle Cable Lug Kit, PN 6706808A01 (shipped with your AXP1440)

### 5.3.2 Rack/Cabinet Cooling Guidelines

It is important to have sufficient open space at the front and rear of the shelf when installed in a rack or cabinet. Depending on whether the enclosure has solid or vented doors will determine the recommended open space required. Follow these guidelines for positioning the shelf to allow for the optimal open space for the shelf air inlet and shelf air exhaust.

Do not obstruct the ventilation openings at the top, sides and back of the shelf.

Figure 5-1 Rack Mounting Dimensions

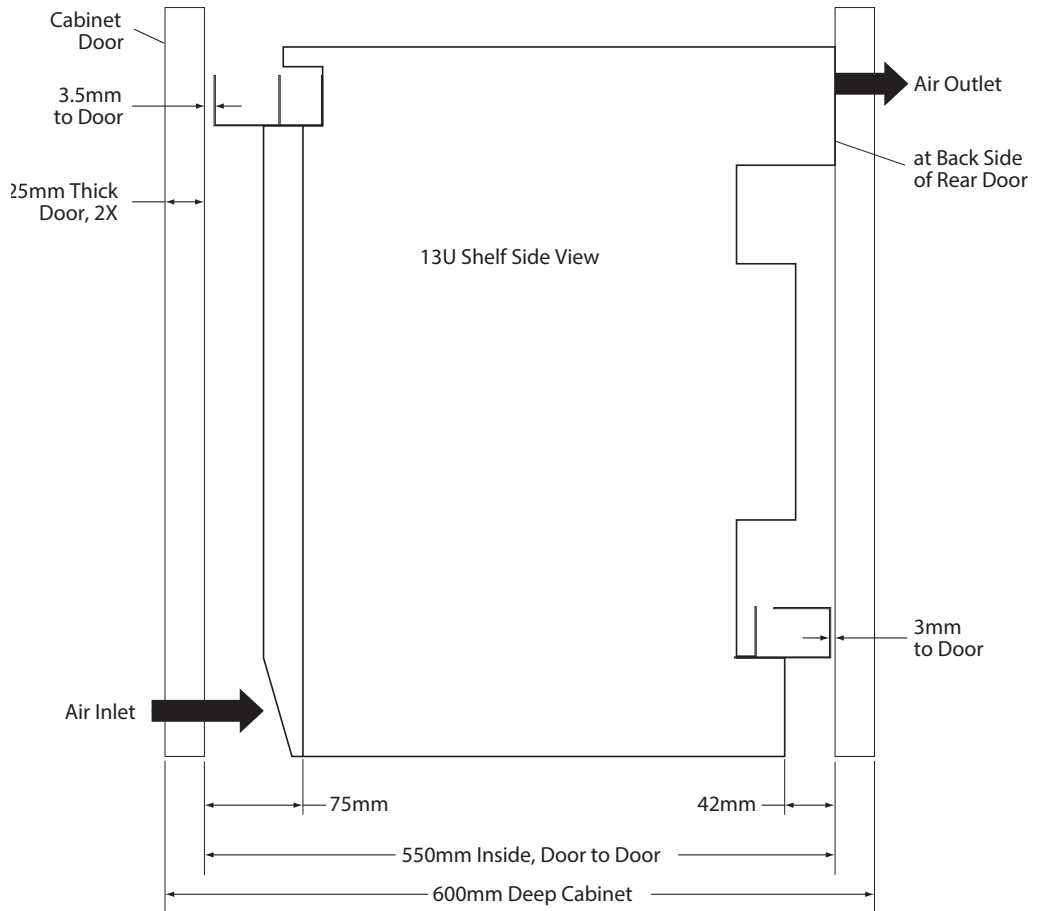

## AXP1440 Shelf Installation

Figure 5-2 Shelf Airflow Diagram

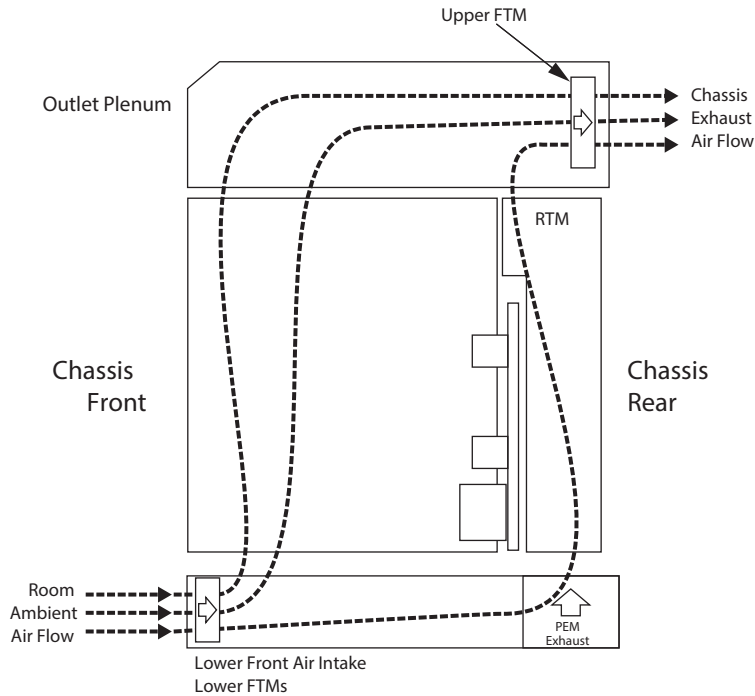

### 5.3.3 Mounting Options and Stabilization

The AXP1440 is designed to be mounted in an equipment rack while maintaining conformance to the NEBS 24" deep lineup and the ETSI 600mm deep lineup standards for telecommunication equipment. For increased stability, we recommend that the rack is securely mounted to the floor, or if using stabilizing devices make sure they are installed and extended.

### 5.3.4 Weight Distribution Within a Rack

	<p><b>To avoid personal injury or damage to the equipment, plan your installation so that (within the limitations of equipment and cabling):</b></p> <ul style="list-style-type: none"> <li><b>The weight of the equipment is evenly distributed in the rack.</b></li> <li><b>The heaviest units are mounted nearer the bottom of the rack.</b></li> </ul> <p><b>Uneven mechanical loading of the rack may cause tipping.</b></p>
---	---

### 5.3.5 Electrostatic Discharge (ESD) and Safety Procedures

Penguin Solutions™ strongly recommends that you use an antistatic wrist strap and a conductive foam pad when installing or upgrading a shelf. Electronic components, such as disk drives, computer boards, and memory modules, can be extremely sensitive to electrostatic discharge (ESD). After removing the component from its protective wrapper or from the shelf, place the component flat on a grounded, static-free surface (and, in the case of a blade, component side up). Do not slide the component over any surface.

If an ESD station is not available, you can avoid damage resulting from ESD by wearing an antistatic wrist strap (available at electronics stores) that is attached to an active electrical ground. Note that a shelf may not be grounded if it is unplugged.

<p><b>Use ESD protection</b></p> 	<ul style="list-style-type: none"> <li><b>There is one earth ground located at the back of the shelf.</b></li> <li><b>There are three ESD bonding points, two on the front and one on the back of the shelf.</b></li> </ul>
---	---

## 5.4 Installing the Shelf

The AXP1440 can be mounted in a 23" EIA or 600mm ETSI frame using front mounting brackets. Using rear mounting brackets is recommended for all frame types when installed in a Central Office Environment. Front or rear mounting brackets are not shipped with this product. For assistance with the acquisition or design of mounting brackets for your particular application, please contact your Penguin Solutions representative.

	<ul style="list-style-type: none"> <li><b>Do not mount a single shelf at the top of the rack. A top-heavy rack can tip, causing damage to equipment and injury to personnel.</b></li> <li><b>Do not use the FTM handles or PEM handles for lifting the shelf.</b></li> <li><b>Make sure you have the appropriate equipment to safely lift and mount the shelf securely. To avoid personal injury or damage to the equipment, use two persons for the installation procedure.</b></li> </ul>
---	---

### 5.4.1 23" EIA Rack/Cabinet

#### Procedure - Install in EIA Rack

Front mounting brackets are required to attach the shelf to an EIA 23" frame.

1. Locate the standard mounting hole and slot locations on the front mounting flanges on the AXP1440 shelf.
2. Fasten the mounting brackets to the back side of the front chassis flanges using M6 screws x 12mm at each of the 5 locations.
3. Be sure to mount the shelf with metal screws or bolts that give a good electrical connection between the screws or bolts and the mounting surface.
4. Tighten all screws using a torque setting of 4.01 to 4.35 N-m.

**NOTE:** Failure to observe proper grounding practices may cause a variety of noise, electrostatic discharge, and RFI (Radio Frequency Interference) problems.

### 5.4.2 600mm ETSI Rack/Cabinet

#### Procedure - Install in 600mm ETSI Rack

The shelf mounts directly from the integrated flange on the front of the shelf.

1. Locate the standard mounting hole and slot locations on the front integrated mounting flanges on the AXP1440 shelf.
2. Fasten the mounting brackets to the back side of the front chassis flanges using M6 screws x 12mm at each of the 5 locations.
3. Be sure to mount the shelf with metal screws or bolts that give a good electrical connection between the screws or bolts and the mounting surface.
4. Tighten all screws using a torque setting of 4.01 to 4.35 N-m.

**NOTE:** Failure to observe proper grounding practices may cause a variety of noise, electrostatic discharge, and RFI (Radio Frequency Interference) problems.



## 5.5 Grounding the Shelf

Use a 2 AWG wire with a 2-hole copper lug and connect directly to the earth ground point located on the right side of the back of the shelf; connect the other end of the wire to a reliable earth ground. Use the torque setting required by the connector supplier. The 2-hole lug prevents rotation of the lug and ensures a permanent bonding of ground to the shelf. The dual hole mount accepts 1/4 #20 screws. Use Panduit LCC2-14AW-Q 2-hole lug or equivalent.

Figure 5-3 Placement of Grounding Lug

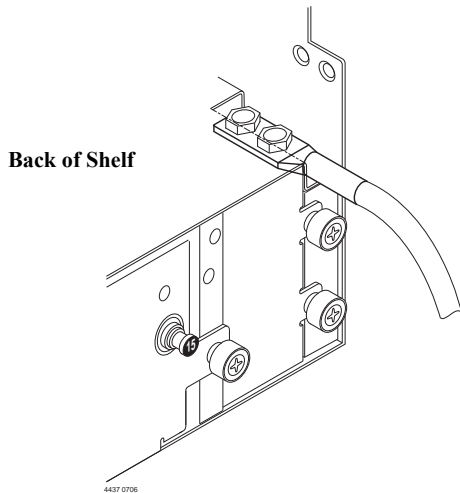

## 5.6 Shelf Ground Configuration

The AXP1440 shelf was tested in the default configuration of logic ground and shelf ground connected and does not connect -48VDC Return with Shelf Ground. The system has been tested in the default configuration and complies with safety and regulatory standards. As a compliant AdvancedTCA shelf, the AXP1440 allows system integrator at their own discretion to remove the mechanism which connects Logic Ground to Shelf Ground and install the mechanism that connects -48VDC Return to Shelf Ground. If the system integrator exercises the option of removing the connections from Logic Ground to Shelf Ground and or adds the connection between -48VDC Return and Shelf Ground, the responsibility for maintaining compliance to CSA (C/US)/VDE safety requirements and EMI/RFI emission limits rests entirely with the system integrator and installer.

### 5.7 DC Power Cable

Power is introduced to the shelf through redundant DC PEMs. The recommended power cable is an 4 AWG that meets the specifications for this shelf. There are four lugs for each PEM. Two are straight and the other two are custom offset lugs. The end that connects to the external DC power source should be equipped with an 8 mm terminal.

#### NOTICE

**Always check with your local building authorities for wire sizing requirements for your environment.**

**The installation must comply with the 1993 National Electric Code (NEC) and other applicable codes.**

**The DC power inputs must only be attached to approved Telephone Network Voltage (TNV) or SELV (Safety Extra Low Voltage) branch circuits. Branch circuits must comply with all requirements called for in these safety standards: IEC 62368-1, EN 62368-1, CAN/CSA-C22.2 No. 62368-1. Attaching inputs to non-TNV/SELV approved power sources will cause the system to fail compliance with safety regulations.**

**The ground wire must be connected to a reliable earth ground connection to comply with Class 1 Equipment requirements.**



**Multiple power sources are present.  
Service only by qualified service personnel.**

**Mehrfache Energiequellen.  
Handhabung nur durch geschultes Personal.**

**Des sources multiples de pouvoir sont présentes.**

**L'entretien de cet équipement doit être effectué par du personnel de service qualifié.**

Wire	Signal
Earth Ground	PE GND (Primary Earth Ground)
Input power	-48VDC nominal to -60VDC
Return	-48VDC RETURN

Figure 5-4 DC Power Connection Detail

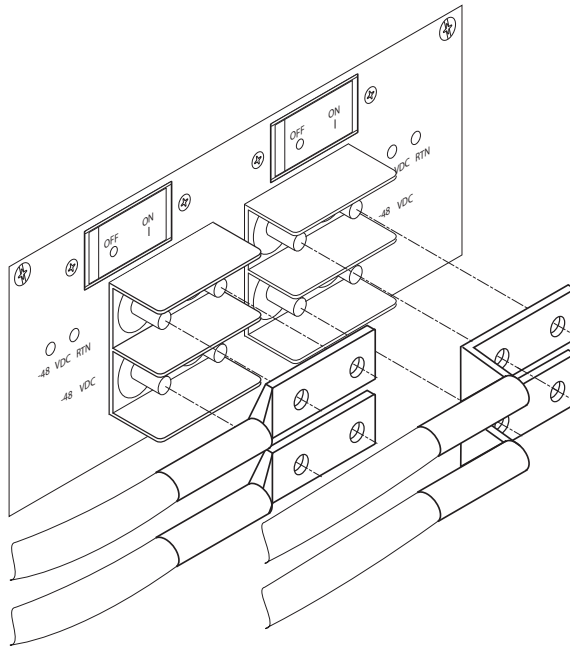

## 5.8 Power Cable Termination

Custom lugs are used with large gauge wires for up to 80 Amps DC (4 AWG) when connecting to the PEM. These are shipped with the product. The lugs are angled to allow the cables to be dressed below the cable management tray, thus protecting the circuit breakers from accidental tripping.

Terminating this lug is identical to terminating standard lugs. To minimize shorting of the terminals, the lugs must be insulated according to [Figure 5-4](#).



**Insulation should be placed as close to the hole as possible (0.15") apart. The insulation tube should be cut approximately at a 30° angle.**

### 5.9 Connecting the Cables to the PEM

In a redundant configuration, each PEM must be connected to a separate DC power source. The 2 separate inputs on a single PEM should be connected to the DC same source. Power is introduced to each PEM's terminal block on the front of the module (power input cable and return cable). The lugs provide secure contact for the cable and prevent the power cables from rotating. A plastic housing covers the power feeds and returns and is attached with one screw. Refer to [Figure 5-4 on page 91](#) for detail

#### NOTICE

To cable a dual breaker DC system, read all cautions and warnings, properly ground the equipment by following the procedure in [Grounding the Shelf on page 89](#), and follow these steps. This procedure assumes that the PEMs are preinstalled in the shelf.

#### Procedure – Connect Cables to PEM



Cables may or may not be preinstalled at the branch circuit or power distribution unit.

If the DC power cables are not connected to the branch circuit or power distribution unit, connect the power cables to the PEMs before connecting the DC power cables to the external power source.

If the DC power cables are connected to the branch circuit or power distribution unit, a qualified service person must confirm that the power to the cables is terminated (off) before continuing the steps to attach the cables to the PEMs.

In either case, use a multimeter to check the PEM end of the terminals to confirm there is no power present.

Have the following tools on hand before you begin these steps: standard Phillips screwdriver, nut driver, torque wrench, multimeter, and lug kit.

1. Locate the target power input cable's terminals at the branch circuit or power distribution unit. Open the external circuit breakers that provide DC feed power to the PEM.
2. Lock and tag out the circuit breakers on the branch circuit or power distribution unit.
3. Using the appropriate tool, carefully remove the plastic covering over the terminal blocks.
4. Confirm that there is no power to the PEM lug bolts. Using a multimeter, measure between the two lugs and then measure between the chassis ground and each lug. If the DC potential is 3.0VDC or less, then power is not present.
5. Attach the DC power cables (input and return) to the dual lug bolts on each PEM.

- Using a torque wrench, tighten the nuts with a recommended torque setting of 4.01 N-m to 4.35 N-m. Make sure all DC leads are fastened securely.
- Replace the plastic cover over the terminal blocks.
- Verify that the circuit breakers are in the ON position.
- Break the ragout or lockout seals on the branch circuit or power distribution unit.
- Apply power by closing the branch circuit or power distribution unit.

The OOS indicator LED glows solid red and the other LEDs will go dark.  
The OOS will not go dark and the IS indicator LED will not illuminate until the external power circuit breakers are closed.
- Verify that all FRU LEDs illuminate and the PEM's IS LED is green, and the OOS LED is dark.

## 5.10 Powering Up the System



**Cover all open module slots and put all approved filler panels in place before turning on power. This is necessary to properly cool the chassis and to avoid electrical shock and other possible hazards. Slot covers and panels must remain in place during system operation.**

With the installation cabled up, you are ready to apply power to the system.

### Procedure – Power Up the System

Follow these steps to power up the system:

- Push the PEM circuit breakers to the ON position.
- Verify that all FRU LEDs illuminate and the PEM's In Service LED is green.

The system executes its normal start-up routine and is then ready to use.

## 5.11 Accessing the System

You can access your system using the SAM shelf manager. The SAM-1500 direct serial console connector (back of chassis) is an RJ-45 connector on the SAM face plate. This connector is configured as DTE. The indirect serial console connector (front of chassis, located on the ADP) is a 9-pin micro-D subconnector. For default user name and password, contact your Penguin Solutions sales representative.

Custom cables are required for these connectors. Refer to [RS-232 Serial Interface on page 123](#) for pin assignments.

# 5.12 Upgrading Firmware

Upgrading firmware on the AXP1440 shelf involves the following components:

- IPMC firmware on the two Fan Tray Modules (FTMs)
- IPMC firmware on the two Power Entry Modules (PEMs)
- Shelf Manager firmware (including an FPGA image) on the two SAMs

## 5.12.1 FTM IPMC Firmware Upgrade

**NOTE:** The upgrade process described here uses a script named `upgradeftm`, which is supplied on shelf managers starting with build 4.1.0-3.

There is a single IPMC firmware image common to the two FTMs in the AXP1440. The FTM IPMCs are assigned IPMB addresses 0x56 and 0x58.

Different upgrade image variants are generated as part of the release, but only one file is required for the normal field upgrade process. This file is `ftm14x0_hpm1fw.img`. As upgrades are released, Penguin Edge will supply the current version of this file.

### Procedure – Upgrade the FTM Firmware

Follow these steps to upgrade the FTM firmware:

1. Copy the `ftm14x0_hpm1fw.img` file to the `/tmp` directory on the active Shelf Manager.

**NOTE:** The `/tmp` directory on the shelf manager is mounted to ram; this copy of the file will be deleted on the next reset of the shelf manager. If you want to save the file to flash, copy it to the `/var/nvdata` directories on both shelf managers.

2. Execute the following command to upgrade the upper FTM:

```
upgradeftm upper /tmp/ftm14x0_hpm1fw.img
```

3. Repeat the command to upgrade the lower FTM:

```
upgradeftm lower /tmp/ftm14x0_hpm1fw.img
```

After a successful upgrade, the `upgradeftm` script displays the current firmware level reported by the device as shown in [FTM Upgrade Sample Output on page 94](#).

4. If necessary, it is possible to revert to the previous firmware version using a command of the form:

```
upgradeftm upper | lower rollback
```

### 5.12.1.1 FTM Upgrade Sample Output

The sample output for these commands for one FTM is shown below.

```
# upgradeftm upper /tmp/ftm14x0_hpmlfw.img
Upgrading...
ipmitool_v0.9 -H 192.168.24.11 -t 0x58 -U openhpi -P openhpi hpm \
    upgrade /var/nvdata/ftm14x0_hpmlfw.img
PICMG HPM.1 Upgrade Agent 0.4:
Validating firmware image integrity...OK
Performing preparation stage...OK
    Target Product ID      : 95
    Target Manufacturer ID: 161
Performing upgrade stage:
    Upgrading H8S-ATCA F/W
    with Version: Major: 1
                    Minor: 8
                    Aux  : 000 000 000 000
Firmware size : 171840
    Writing firmware: 100% completed
Firmware upgrade procedure successful
ipmitool returned 0.
Activating...
ipmitool_v0.9 -H 192.168.24.11 -t0x56 -U openhpi -P openhpi hpm
activate
PICMG HPM.1 Upgrade Agent 0.4:
ipmitool returned 0.
/bin/upgradeftm: Upgrade and activate complete.
Verify firmware version:
clia ipmc -v 0x56
Pigeon Point Shelf Manager Command Line Interpreter
58: Entity: (0x1e, 0x60) Maximum FRU device ID: 0x00
    Hot Swap State: M4 (Active), Previous: M3 (Activation In
Process), Last
State Change Cause: Normal State Change (0.0)
    Device ID: 0x00, Revision: 0, Firmware: 0.00 (ver 0.0.0), IPMI
ver 0.0
    Manufacturer ID: 000000, Product ID: 0000, Auxiliary Rev:
00000000
    Device ID String: "FTM14x0"
    Global Initialization: 0xc, Power State Notification: 0xc,
Device Capabilities: 0x29
    Controller does not provide Device SDRs
    Supported features: 0x00
```

### 5.12.2 PEM IPMC Firmware Upgrade

**NOTE:** The upgrade process described here uses a script named `upgradepem`, which is supplied on shelf managers starting with build 4.1.0-3.

There is a single IPMC firmware image common to the two PEMs in the AXP1440. The PEM IPMCs are assigned IPMB addresses 0x66 and 0x68.

The file containing the firmware image is `pem1620.img`. As upgrades are released, Penguin Edge will supply the current version of this file.

#### Procedure – Upgrade the PEM Firmware

Follow these steps to upgrade the PEM firmware:

1. Copy the `pem1620.img` file to the `/tmp` directory on the active Shelf Manager.

**NOTE:** The `/tmp` directory on the shelf manager is mounted to ram; this copy of the file will be deleted on the next reset of the shelf manager. If you want to save the file to flash, copy it to the `/var/nvdata` directories on both shelf managers.

2. Execute the following command to upgrade one PEM:

```
upgradepem pem1 /tmp/pem1620.img
```

After a successful upgrade, the `upgradepem` script displays the current firmware level reported by the device as shown in [PEM Upgrade Sample Output on page 96](#).

3. Repeat this command to upgrade the other PEM:

```
upgradepem pem2 /tmp/pem1620.img
```

#### 5.12.2.1 PEM Upgrade Sample Output

The sample output for this command for one PEM is shown below.

```
# upgradepem pem1 /tmp/pem1620.img
Upgrading...
upgradefw -I /dev/i2c5:0x66 /tmp/pem1620.img
BMR-AVR firmware upgrade utility. Pigeon Point Systems (c) 2004.
Upgrade interface: IPMB, device: /dev/i2c5, options: 0x66
Firmware upgrade image: /tmp/pem1620.img
Preparing Master AVR for programming ..... OK
Programming 39703 bytes to Master AVR at 000000 ... 100%
Preparing Slave AVR for programming ... OK
Programming 7008 bytes to Slave AVR at 000000 ... 100%
upgradefw returned 0.
/bin/upgradepem: Upgrade complete.
```



```
Verify firmware version:
# clia ipmc -v 0x66
Pigeon Point Shelf Manager Command Line Interpreter
66: Entity: (0xa, 0x60) Maximum FRU device ID: 0x01
    PICMG Version 2.1
    Hot Swap State: M4 (Active), Previous: M3 (Activation In
Process), Last State Change Cause): Normal State Change (0x0)
    Device ID: 0x01, Revision: 0, Firmware: 1.03 (ver. 1.0.3), IPMI
ver 1.5
    Manufacturer ID: 0000a1, Product ID: 005e, Auxiliary Rev:
00000018
    Device ID String: "PEM1620"
    Global Initialization: 0xc, Power State Notification: 0xc,
Device Capabilities (0x29)
    Controller provides Device SDRs
    Supported features: 0x29
    "Sensor Device" "FRU Inventory Device" "IPMB Event Generator"
```

### 5.12.3 Shelf Manager Firmware Upgrade

There are three files which contain the ShM firmware: **sentry.shmm1500.kernel**, **sentry.shmm1500.rfs**, and **sentry.shmm1500.u-boot.bin**. All files should be loaded onto both ShMs using the procedures described here. These files also contain firmware to be loaded into the SAM1500 FPGA. The SAM1500 FPGA will be programmed automatically (if necessary) by the process.

As upgrades are released, Penguin Edge will supply the current version of these files.

#### Procedure – Upgrade the Shelf Manager

**NOTE:** If you are starting from an earlier version of shelfman (prior to PPS 2.5.2), your configuration files will not be preserved across an upgrade, and you will need to restore any special configuration settings by editing the .conf files after the upgrade.

The upgrade process involves the following steps.

1. Preserving and restoring configuration settings.

Normally, any configuration settings saved in **/etc/shelfman.conf** and **/etc/shelfman.conf.sam1500** are preserved during the upgrade procedure (if starting with a version of shelfman that is at revision PPS 2.5.2 or higher), so you do not need to save and restore unique settings saved in these files. Occasionally,

## AXP1440 Shelf Installation

---

a firmware upgrade presents a change in the options presented in these configuration files. If this is the case, you can note any changes to settings you have made to these files and perform the upgrade so it overwrites these configuration files. You then must edit these text files to reapply your changes.

2. Upgrading the U-boot, kernel, and root file system images.  
This is the normal upgrade sequence.
3. Upgrading the FPGA firmware on the SAM.  
The startup logic (following the root file system upgrade) automatically detects the need to upgrade the FPGA. If an upgrade is necessary, the startup logic loads the FPGA and automatically reboots the ShM again. If this occurs, you should note a delay of approximately 5-8 minutes while this download occurs.
4. Updating the default U-boot environment variable configuration.  
The upgrade procedure preserves all U-boot environment variables. No special procedures are necessary.  
Start the following sequence of operations with the backup Shelf Manager.

### 5.12.3.1 Establishing Network Connectivity to the SAM

The list below outlines the different actions required to enable and use the front panel Ethernet interface on a SAM. If the upgrade is being performed over the backplane Ethernet interfaces from one of the hub boards, skip these steps.

1. Login to the SAM front panel serial console using the id `root` and password `root`. Earlier firmware versions use the password `motorola`.
2. Set the environment variable that defines the IP address allocated for the SAM's front panel Ethernet interface.  

```
# setenv ip1addr W.X.Y.Z (substituting your address)
# ifconfig eth1 W.X.Y.Z
```
3. If your file server (for Penguin Edge files) is on a different subnet:  

```
# route add default gw W.X.Y.Z (you will need to do this each time you reboot).
```

 If you use the Uboot environment variable `gatewayip`, the route is set automatically at reboot (`setenv gatewayip W.X.Y.Z`).
4. If the local subnet is not a class 'C' subnet, you may need to also execute the command:  

```
# ifconfig eth1 netmask ...
```

 to alter the netmask used by the ethernet interface.  
If you use the Uboot environment variable `netmask1`, this subnet mask is set automatically at boot up (`setenv netmask1 netmask`)

5. Ping the file server containing the Penguin Edge files. You should get a response if the Ethernet cable is connected.
6. Set the environment variable that keeps the front panel Ethernet interface enabled following a reboot.

```
# setenv enable_front_panel_ethernet y
```

### 5.12.3.2 Update ShM Firmware on the SAM

This step involves programming of the U-boot, Linux kernel, and root file system into flash on the ShMM1500 on the SAM.

1. Copy the three required firmware image files listed below to the `/tmp` directory on the ShM:

- `sentry.shmm1500.u-boot.bin`
- `sentry.shmm1500.kernel`
- `sentry.shmm1500.rts`

One way of doing this is:

```
# scp acctname@filesaver_ip:dirname/sentry.shmm1500.* /tmp
```

where:

`acctname` is the login account for the user on the (linux) file server

`filesaver_ip` is the IP address of the file server

`dirname` is the relative directory name (from the login home) for the location of the images

Verify that the files were copied to `/tmp`.

2. Execute the command to program these images into flash and then reset to execute the new images:

```
# rupgrade_tool -s -v -d -a [--hook=erase]
```

The `--hook=erase` argument is optional, and is normally not used. This directs the upgrade procedure to avoid preserving the customer-specific configuration files, `/etc/shelfman.conf` and `/etc/shelfman.conf.sam1500`. Normally, these files should be preserved across an upgrade, but on occasion, when Penguin Edge makes a change to the format of the configuration options, you may be instructed to use this option. In this case, you need to re-enter the configuration by editing these files following the upgrade.

3. The files are copied to flash memory and the system should reboot in a couple of minutes. When the system is restarted, the boot up logic automatically determines if the SAM1500 FPGA needs to be loaded to a new firmware revision. If so, an additional upgrade and reboot takes place and takes an additional 5-8 minutes. The SAM should now be running the new firmware.

## **AXP1440 Shelf Installation**

---

The process can now be repeated with the other Shelf Manager.

# FRU Installation

## 6.1 Overview

The following sections help you to start up and maintain the system:

- [Installing RTMs, Blades and SAMs on page 101](#), describes the steps needed to install and remove RTMs, AdvancedTCA blades, and shelf management alarm modules.
- [Unused Slots on page 111](#), provides information how to cover empty slots.
- [Installing Power Entry Modules on page 111](#), describes the steps needed to install and remove Power Entry Modules.
- [Upper and Lower Fan Tray Modules on page 114](#), provides information about how to install and remove upper and lower fan trays.
- [Replacing the Fan Filter on page 117](#), provides information about how to install and remove an air filter.

## 6.2 Installing RTMs, Blades and SAMs

The following sections provide the information needed to install RTMs, AdvancedTCA blades, and SAMs.

### 6.2.1 Module Installation and Removal

The RTM can be installed into a powered or non-powered system providing its front blade is powered down.

	<p><b>Product Damage</b></p> <p>Installing the RTM with other blades than the ones designed for it may damage the RTM and the front blade.</p> <p>Only install the RTM with the correct front blade.</p>
---	--

<p>Use ESD protection</p> 	<p><b>Damage of Circuits</b></p> <p>Electrostatic discharge and incorrect RTM installation and removal can damage circuits or shorten their life.</p> <p>Before touching the RTM or electronic components, make sure that you are working in an ESD-safe environment.</p>
---	---

#### 6.2.1.1 Installing the RTM

You can install the RTM into a system if the front blade is already installed or if it is not installed. If the front blade is already installed, its payload has to be powered down first.

### Procedure – RTM with Installed Front Blade

The following procedure describes the installation of the RTM. It assumes that your system is powered. If your system is non-powered, you can disregard the blue LED and thus skip the respective step. In this case it is a purely mechanical installation.

1. Locate the slot the RTM is to be installed into the shelf's rear which must be the same as that of the front blade.
2. Open the lower handle of the front blade in order to power down its payload.  
The blue LED on the front blade starts to flash. This indicates that the front blade is informing the shelf manager about its desire to power down its payload.
3. Wait until the blue LED on the front blade is ON.  
This indicates that the front blade's payload is powered down.
4. Make sure that the top and the bottom handles of the RTM are in an outward position by squeezing the lever and the latch together.

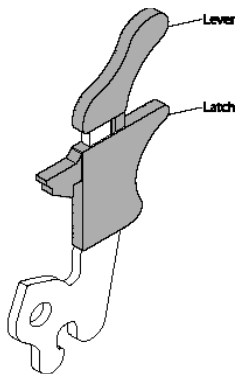

5. Insert the RTM into the shelf by placing the top and bottom edges in the card guides of the slot.
6. Slide the RTM into the slot.
7. Apply equal and steady pressure to the RTM to carefully slide the RTM into the shelf until you feel resistance. Continue to gently push the RTM until the RTM connectors engage.
8. Squeeze the lever and the latch together and hook the lower and the upper handle into the shelf rail recesses.

9. Fully insert the RTM and lock it to the shelf by pressing the two components of the lower and the upper handles together and turning the handles toward the face plate.

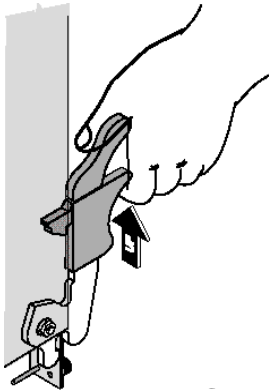

If your shelf is powered, as soon as the RTM is connected to the front blade, the blue LED is illuminated, and will remain illuminated until both the lower handle of the RTM and the lower handle of the front blade are closed.

10. Close the lower handle of the front blade in order to power up the payload of both the front blade and the RTM.

The blue LEDs of both the front blade and the RTM start to flash. This indicates that the front blade is informing the shelf manager about its desire to power up the payload of both the front blade and the RTM.

11. Tighten both face plate screws on the RTM.
12. Wait until the blue LEDs of both the front blade and the RTM are OFF.  
A switched OFF blue LED indicates that the payload of the respective blade or RTM has been powered up and is active.
13. Plug interface cable into face plate connectors, if applicable.

### **Procedure – No Installed Front Blade**

The following procedure describes the installation of the RTM without a front blade installed.

1. Locate the slot the RTM is to be installed into the shelf's rear which must be the same as that of the front blade.

## FRU Installation

---

2. Ensure that the top and the bottom handles of the RTM are in an outward position by squeezing the lever and the latch together.

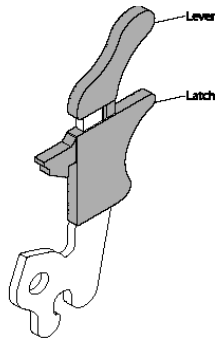

3. Insert the RTM into the shelf by placing the top and bottom edges in the card guides of the slot.
4. Slide the RTM into the slot.
5. Apply equal and steady pressure to the RTM to carefully slide the RTM into the shelf until you feel resistance. Continue to gently push the RTM until the RTM connectors engage.
6. Squeeze the lever and the latch together and hook the lower and the upper handle into the shelf rail recesses.
7. Fully insert the RTM and lock it to the shelf by pressing the two components of the lower and the upper handles together and turning the handles toward the face plate.

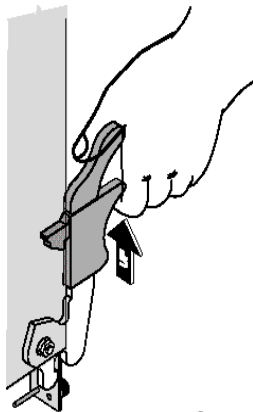

8. Tighten both face plate screws on the RTM.
9. Insert the front blade from the system's front into the same slot as the RTM.



As soon as the front blade is connected to the backplane, the blue hot swap LEDs of both the front blade and the RTM are illuminated permanently. This indicates that the IPMC of the front blade and the MMC of the RTM are powered up.

10. Close the handles of the front blade.

The blue LEDs on both the front blade and the RTM start flashing. This indicates that the front blade is informing the shelf manager about its desire to power up the payload of both the front blade and the RTM.

11. Tighten the two face plate screws on the front blade.

12. Wait until the blue LEDs on both the front blade and the RTM are OFF.

Switched off blue LEDs indicate that the payload of the respective blade or RTM has become active.

13. Plug interface cable into face plate connectors, if applicable.

### 6.2.1.2 Removing the RTM

	<p><b>Product Damage</b></p> <p><b>Removing the RTM from the system while the payload of the front blade is powered up may damage the front blade and RTM.</b></p> <p><b>Whenever removing the RTM from the system, you must first power down the payload of the front blade.</b></p>
---	---

	<p><b>Data Loss</b></p> <p><b>Removing the RTM with the system power on and the blue LED on the front blade still flashing causes data loss.</b></p> <p><b>Before removing the RTM from a powered system, power down the slot by opening the lower handle of the front blade and wait until the blue LED is permanently ON.</b></p>
---	---

#### Procedure – Remove RTM

The following procedure describes the removal of the RTM. It assumes that your system is powered. If your system is non-powered, you can disregard the blue LED and skip the respective step. In this case it is a purely mechanical procedure.

1. Unlatch the lower handle outward by squeezing the lever and the latch together and turning the handle outward only enough to unlatch the handle from the face plate, that means until you feel a resistance. Do not rotate the handle fully outwards.

The blue LED blinks indicating that the shelf manager is informed about the desire of the blade to power down the payload of both the front blade and the RTM and the power-down process is ongoing.

2. Wait until the blue LEDs on both the front blade and the RTM are permanently ON.

## FRU Installation

---

A permanently switched ON LED indicates that the payload of respective blade or RTM has been powered down.

3. Unlatch the upper handle and rotate both handles fully outward.
4. Remove interface cables from face plate connectors, if applicable.
5. Loosen the two RTM face plate screws.
6. Remove the RTM from the slot.

### 6.2.2 Node Blade Installation and Removal

The blade is fully compatible to the AdvancedTCA standard and is designed to be used in AdvancedTCA shelves. The blade can be installed in any AdvancedTCA node slot. The following cautions apply to both the installation and remove procedures.

<p><b>Use ESD protection</b></p> 	<p><b>Damage of Circuits</b></p> <p>Electrostatic discharge and incorrect blade installation and removal can damage circuits or shorten their life.</p> <p><b>Before touching the blade or electronic components, make sure that you are working in an ESD-safe environment.</b></p>
--	--

	<p><b>Blade Malfunctioning</b></p> <p>Incorrect blade installation and removal can result in blade malfunctioning.</p> <p><b>When inserting or removing the blade, use the handle - do not press on the face plate.</b></p>
--	---

#### 6.2.2.1 Installing the Node Blade

To install the blade into an AdvancedTCA shelf, proceed as follows.

##### Procedure – Install the Blade

The following procedure describes the installation of the blade. It assumes that your system is powered. If your system is non-powered, you can disregard the blue LED and thus skip the respective step. In this case it is a purely mechanical installation.

1. Make sure that the top and bottom ejector handles are in the outward position by squeezing the lever and the latch together.

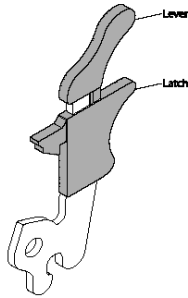

2. Insert blade into the shelf by placing the top and bottom edges of the blade in the card guides of the shelf. Ensure that the guiding module of shelf and blade are aligned properly.
3. Apply equal and steady pressure to the blade to carefully slide the blade into the shelf until you feel resistance. Continue to gently push the blade until the blade connectors engage.
4. Squeeze the lever and the latch together and hook the lower and the upper handle into the shelf rail recesses.
5. Fully insert the blade and lock it to the shelf by squeezing the lever and the latch together and turning the handles towards the face plate.

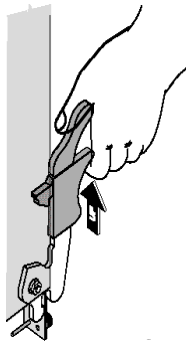

If your shelf is powered, as soon as the blade is connected to the backplane power pins, the blue LED is illuminated.

When the blade is completely installed, the blue LED starts to blink. This indicates that the blade announces its presence to the shelf management controller.

**NOTE:** If an RTM is connected to the front blade, make sure that the handles of **both** the RTM and the front blade are closed in order to power up the blade's payload.

## FRU Installation

---

6. Wait until the blue LED is switched off, then tighten the face plate screws which secure the blade to the shelf.  
The switched off blue LED indicates that the blade's payload has been powered up and that the blade is active.
7. Connect cables to the face plate, if applicable.



**After the blade has been inserted, make sure that a boot image is present on the ATCA-F120 or on the blade's hard disk.**

### 6.2.2.2 Removing the Node Blade

This section describes how to remove the blade from an AdvancedTCA system.

#### Procedure – Remove Blade

The following procedure describes how to remove the blade from a system. It assumes that the system is powered. If the system is non-powered, you can disregard the blue LED and thus skip the respective step. In that case it is a purely mechanical procedure.

A yellow triangular warning icon with a black exclamation mark in the center.	<p><b>Data Loss</b> <b>Removing the blade with the blue LED still blinking causes data loss.</b> <b>Wait until the blue LED is permanently illuminated, before removing the blade.</b></p>
---	--

1. Unlatch the lower handle by squeezing the lever and the latch together and turning the handle outward only enough to unlatch the handle from the face plate. Do not rotate the handle fully outward.

The blue LED blinks indicating that the blade power-down process is ongoing.

2. Wait until the blue LED is illuminated permanently, then unlatch the upper handle and rotate both handles fully outward.

**NOTE:** If the LED continues to blink, a possible reason may be that upper layer software rejects the blade extraction request.

3. Remove face plate cables, if applicable.
4. Unfasten the screws of face plate until the blade is detached from shelf.
5. Remove the blade from the shelf.

## 6.2.3 Installing and Removing the Shelf Management Alarm Module

The following sections describe the installation and removal procedures for the shelf management alarm module (SAM-1500R). For a detailed description of the SAM, refer to [Chapter 7, Shelf Management Alarm Module on page 119](#).

The following figure shows the face plate of the SAM-1500R shelf management alarm module.

Figure 6-1 SAM-1500R

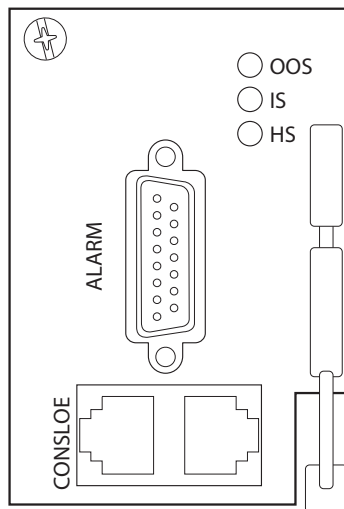

### 6.2.3.1 Non-powered System

This section describes the installation procedure for the SAM in non-powered systems.

<p><b>Use ESD protection</b></p> 	<p><b>Damage of Circuits</b></p> <p><b>Electrostatic discharge and incorrect blade installation and removal can damage circuits or shorten their life.</b></p> <p><b>Before touching the blade or electronic components, make sure that you are working in an ESD-safe environment.</b></p>
--	---

#### Procedure – Install SAM in Non-powered System

To install a SAM in a non-powered shelf, proceed as follows:

1. Put on an ESD wrist strap.
2. Connect the strap to the shelf by attaching the front or rear ESD jack.

## FRU Installation

---

3. Insert the module into the shelf by placing the top and bottom edges of the module in the card guides of the shelf. Ensure that the guiding module of shelf and board are aligned properly. The alignment pin facilitates the insertion and prevents bent pins.
4. Slide the module into the shelf and rotate the ejector handle upward until it snaps into place.
5. Screw in the captive screw hand tight.

### **Procedure – Remove SAM from Non-powered System**

To remove a SAM from a non-powered shelf, proceed as follows:

1. Put on an ESD wrist strap.
2. Connect the strap to the shelf by attaching the front or rear ESD jack.
3. Unfasten the captive screw at the upper left hand corner of the face plate until the board is detached from the shelf.
4. Unlock ejector handle by pressing the handle and pull down. The SAM should start to move out of the chassis. Do not force it. If the SAM does not move, it means the captive screw is not fully unscrewed. Unscrew until loose and rotate the ejector handle down.
5. Remove the module from the shelf.

### **6.2.3.2 Powered System**

This section describes the installation and removal procedures for a SAM in powered systems.

### **Procedure – Install SAM in Powered System**

To install a SAM in a powered shelf, proceed as follows:

1. Put on an ESD wrist strap.
2. Connect the strap to the shelf by attaching the front or rear ESD jack.
3. Insert the module into the shelf by placing the top and bottom edges of the board in the card guides of the shelf. Ensure that the guiding module of shelf and board are aligned properly. The alignment pin facilitates the insertion and prevents bent pins.
4. Slide the module into the shelf and rotate the ejector handle upward until it snaps into place.
5. Wait until the blue LED is illuminated.
6. Screw in the captive screw hand tight. The blue LED blinks.
7. Wait until the blue LED is switched OFF. The switched off blue LED indicates that the board is activated.

### Procedure – Remove SAM from powered System

To remove a SAM from a powered system, proceed as follows:

1. Put on an ESD wrist strap.
2. Connect the strap to the shelf by attaching the front or rear ESD jack.
3. Unfasten the captive screw at the upper left hand corner of the face plate until the module is detached from the shelf.
4. The blue LED blinks indicating that the module power down process is ongoing.
5. Wait until the blue LED is illuminated permanently.



#### Data Loss

**Removing the module with the blue LED still blinking causes data loss. Wait until the blue LED is permanently illuminated, before removing the module.**

6. Unlock ejector handle by pressing the handle and pull down.  
The SAM should start to move out of the chassis. Do not force it. If the SAM does not move, check the captive screw to make sure it is fully unscrewed. Unscrew until loose and rotate the ejector handle down.
7. Remove the module from the shelf.

## 6.3 Unused Slots

All unused node or hub slots must be covered with filler blades. These filler blades ensure a consistent airflow per slot whether or not the neighboring slot contains an AdvancedTCA blade. There are filler blades sized for the front and for the RTM slots. An unused slot cannot contain a front filler when an AdvancedTCA RTM is installed. When fillers are used, both the front and RTM filler must be in place. Filler blades are available from Penguin Edge.

## 6.4 Installing Power Entry Modules

The AXP1440 shelf supports two Power Entry Modules (PEMs). Since the shelf is equipped with a redundant power distribution system, the removal of a single PEM does not interrupt system operation. PEMs are accessible from the rear of the shelf. Each PEM has EMI gaskets on all sides of the module that provide EMI shielding.

## FRU Installation

The following instructions describe how to replace a power entry module. For further information on power entry modules, refer to [Power Entry Modules \(PEMs\) on page 58](#).

	<p>Read all cautions and warnings, and make sure the equipment is properly grounded by reviewing the procedure in <a href="#">Grounding the Shelf on page 89</a>. The PEM has multiple power sources. This procedure should be followed precisely to ensure the PEM is isolated from all power sources before removing the PEM from the shelf, or removing the plastic terminal block lug cover.</p> <p>This procedure assumes that the redundant PEMs are powered on in the shelf.</p>
---	---

### 6.4.1 Tools You Will Need

- Multimeter
- Standard #2 Phillips-head screwdriver
- 7/16" torque wrench
- Nut driver (torque nut to 5.65 N-m)
- AXP1440 DC Power Installation Kit, PN 6706822A01 (shipped with AXP1440)

### 6.4.2 Replacing the PEM

When replacing a PEM, make sure you have a replacement PEM available. Replacement can take place in under 30 minutes by a qualified service person. PEMs are accessible from the rear of the shelf.

Replacing one PEM is done while the other PEM is in operation. Having the PEM located in the shelf is critical to maintaining proper airflow and cooling of the shelf. Steps in which a PEM is removed from a slot and reinserted should be completed within 3 minutes to maintain the shelf within safe operating temperatures.

#### Procedure – Remove the PEM

To remove a PEM, refer to this figure and follow the steps.

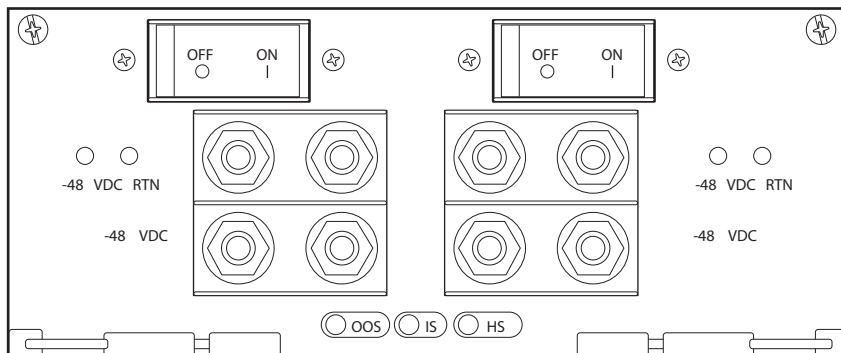



1. Turn off both breakers located on the PEM.

**NOTE:** To turn off the breakers, you need to use a tool (small screwdriver) which can be inserted into the opening of the protective covers which are assembled over top of these breakers. When the breaker is turned to the **OFF** position, the red part of the breaker switch will be exposed.

2. Locate the target power input cable's terminals at the branch circuit or power distribution unit. Open the external circuit breakers that provide DC feed power to the PEM you are replacing.
3. Lock and tag out the circuit breakers on the branch circuit or power distribution unit.
4. Open the ejector latches. This signals the switch to deactivate the hot swap signal. Watch for the blue LED to go solid and steady, signaling that it is ready to remove.
5. Using the appropriate tool, carefully remove the terminal block cover (plastic covering) over the terminal block. The terminal block cover is attached to the terminal block by two tabs with slots in the cover that insert into embossments in the terminal block wall.
  - Remove the cover, by pressing the upper wall of the terminal block wall downward and slip a flat-bladed screwdriver between the cover and the terminal block wall.
  - Pry the cover tab up to relieve it from the embossment in the terminal block wall. Once the upper cover tab is free from the terminal block embossment, the cover should rotate downward and free itself from the lower embossment.



**If the multimeter indicates there is still power present and power cannot be removed from the terminals, the entire shelf must be powered down to perform the PEM replacement.**

6. Confirm that there is no power to the PEM lug bolts. Using a multimeter, measure between the two lugs and then measure between the chassis ground and each lug. If the DC potential is 3.0 VDC or less, then power is not present.
7. Remove the DC power cables from the dual lug bolts on the PEM you are replacing, being careful to place the two cables so they cannot short to each other or to other conductors. Using the appropriate tool, loosen the chassis retention screws on each side of the PEM.
8. Open the ejector handles completely. You will see the PEM disconnect from the backplane.
9. Pull the module straight out from the rail guides.

### Procedure – Install the PEM

To install a PEM, follow these steps:

1. Make sure that the PEM breakers are in the off position.

## FRU Installation

---

2. Insert the new PEM, closing the ejector handles.
3. Using the appropriate tool, tighten the chassis retention screws on each side of the PEM.
4. Using the appropriate tool, carefully remove the terminal block cover (plastic covering) over the terminal block. The terminal block cover is attached to the terminal block by two tabs with slots in the cover that insert into embossments in the terminal block wall.
  - Remove the cover by pressing the upper wall of the terminal block wall downward and slip a flat-bladed screwdriver between the cover and the terminal block wall.
  - Pry the cover tab up to relieve it from the embossment in the terminal block wall. Once the upper cover tab is free from the terminal block embossment, the cover should rotate downward and free itself from the lower embossment.
5. Install the DC power cables to the dual lug bolts on the PEM.
6. Locate the target power input cable's terminals at the branch circuit or power distribution unit. Close the external circuit breakers that provide DC feed power to the PEM you are replacing.
7. Confirm whether the power to the PEM lug bolts is correct. Using a multimeter, measure between the two lugs. Ensure that the voltage is of the correct polarity.
8. Close the breakers on the PEM. Make sure that the IS LED turns green.

## 6.5 Upper and Lower Fan Tray Modules

To prevent system damage, the operator must replace the fans within the recommended service interval shown in the following table to prevent a decline in shelf operability. Make sure the replacement FTM is available for exchange and ready to install.

Service Interval for 1 FTM	Temperature Range
Not recommended	40-55°C
Four hours	40°C maximum

When an FTM is taken out of operation, the system manager will compensate for the loss by increasing the speed of the remaining fans, as needed. Please read the following caution before replacing any of the FTMs

## 6.5.1 Removing the Upper FTM



Fans may continue to rotate after power is removed. Keep fingers away from the bottom of the FTM enclosure.

### Procedure – Remove Upper FTM

Follow these steps and refer to the figures to remove the upper fan tray module from the shelf.

1. Loosen the retention screw to the chassis before loosening the ejector handle screw.

Figure 6-2 Upper Rear FTM Ejector Handles and LEDs

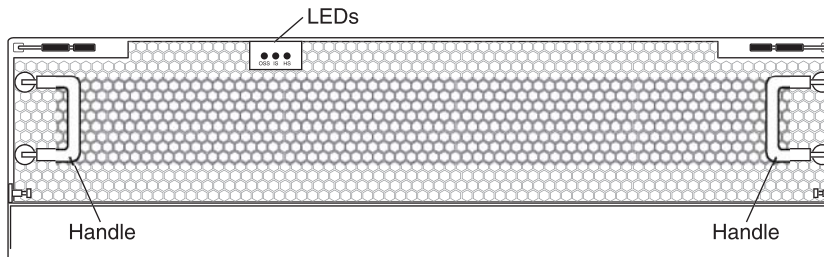

2. Pull the ejector handle outward to a slightly open position to disengage the hot swap switch.
3. Watch for the blue LED to blink. When the blinking stops and the LED remains a solid blue, the FTM is ready to be removed.
4. Open the ejector handle to a full open position.
5. Using the handle on the front of the FTM, slowly pull the FTM out of the shelf, while supporting the bottom of the module with the palm of your hand.

**NOTE:** The module is heavy. Hold it securely.

## 6.5.2 Installing the Upper FTM

### Procedure – Install Upper FTM

Have the correct FTM available and follow these steps to install the upper fan tray module.

1. While supporting the FTM, align the FTM carefully into the fan slot in the shelf and slowly slide the FTM until the ejector handles engage; fully close the handles.

## FRU Installation

---

The FTM is connected when the assembly is firmly seated in the upper backplane connector and the hot swap handle moves to the closed position.

2. Hand tighten both chassis retention screws **at the same time** to secure the FTM.
3. Hand tool tighten both chassis retention screws, alternating back and forth until hand tight. The recommended torque settings is 0.56 N-m.

When the blue LED turns off, the fan is operating.

### 6.5.3 Removing the Lower FTM

#### Removal Procedure

Follow these steps and refer to the figure to remove the lower front fan tray module from the shelf.

Using a Phillips screwdriver, loosen the two chassis retention screws.

*Figure 6-3 Lower Front FTM Ejector Handles and LEDs*

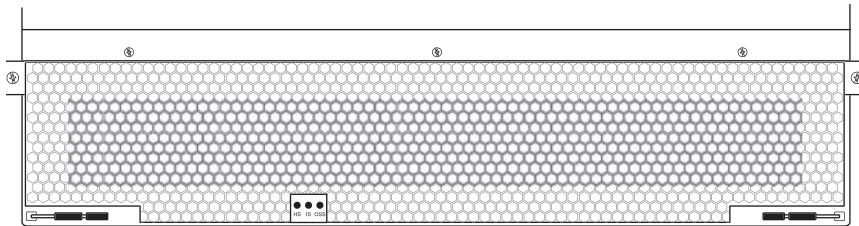

4. Open the ejector handle and wait for the Blue LED to go solid and steady. This indicates that the FTM is ready to be removed.
5. Open the ejector handle to a full open position.
6. Using the ejector handle on the front of the FTM, slowly pull the FTM out of the shelf, while supporting the bottom of the module with the palm of your hand.

**NOTE:** The module is heavy. Hold it securely.

### 6.5.4 Installing the Lower FTM

#### Installation Procedure

Have the correct FTM available and follow these steps to install the upper fan tray module.

1. While supporting the FTM, align the FTM carefully into the fan slot in the shelf and slowly slide the FTM until the ejector handles engage; fully close the handles.

The FTM is connected when the assembly is firmly seated in the upper backplane connector and the hot swap handle moves to the closed position.

2. Hand tighten both chassis retention screws **at the same time** to secure the FTM.
3. Hand tool tighten both chassis retention screws, alternating back and forth until hand tight. The recommended torque settings is 0.56 N-m.

When the blue LED turns off, the fan is operating.

## 6.6 Replacing the Fan Filter

Your replacement fan filter consists of a filter media for the lower fan tray module. The fan filter housing is kept in place by two tabs located on the inner left-side in front of the stationary metal frame.

- Air filters should be checked occasionally to make sure they are not obstructed or damaged
- Visually inspect filters for tears or rips
- Do not reinstall a torn filter as it will be ineffective in trapping particulates and will interrupt air flow distribution
- To maintain safety certification, use only Penguin Edge approved fan filters

You can order replacement fan filters (part number RAF1620) by contacting your Penguin Solutions sales representative. For detailed information on filter maintenance and cleaning, see [Air Filter Maintenance on page 79](#).

### Procedure – Replace Lower FTM

To replace the fan filter for a lower FTM, refer to [Removing the Lower FTM on page 116](#) and follow these steps to replace a fan filter. Please have your replacement fan filter available before starting this procedure.

1. With the FTM removed and placed on a solid surface, position the FTM with the front facing you.
2. Using your fingers, rotate the filter frame away from the housing using the two tabs on the right and left sides of the filter frame.
3. Rotate the vane assembly out of the way to expose the lower portion of the air filter.

## FRU Installation

---

4. Insert the replacement fan filter by positioning the filter onto the Velcro edges and form into place.



**Any particulates that fall into the fan tray module during the air filter replacement must be cleaned out (vacuumed) from the fan tray prior to reinstalling the fan tray into the chassis.**

5. Lower the vane assembly and rotate the filter bracket into place.
6. Reinstall the lower FTM using the procedure described in [Installing the Lower FTM on page 116](#).

# Shelf Management Alarm Module

---

## 7.1 Overview

This chapter describes the AdvancedTCA Shelf Management Alarm Module, hereafter known as the SAM, which consists of the Shelf Management Controller (ShMC) and the Shelf Management Mezzanine Module (ShMM) which installs on the carrier blade. Two SAMs are installed into two dedicated shelf manager slots located at the bottom-rear of the AXP1440 shelf. The SAM is hot swappable and the connectors are accessible through the face plate.

You can find the following information in this chapter:

- [Features](#)
- [SAM Diagram and Face Plate Layout](#)
- [Functional Description](#)
- [Management and Control](#)
- [Telco Alarm Functionality](#)
- [Hot Swap Interface](#)
- [Power](#)
- [SAM Software](#)

The SAM supports redundant operation by automatic switchover between two SAMs. When two SAMs are present in a shelf, one acts as the Active SAM and the other acts as a Standby SAM. They share signals across the AdvancedTCA backplane that allow them to coordinate their redundant operations. The SAM provides access to the IPMCs for the Power Entry Module (PEM) and the two fan trays through the IPMB. The SAMs use IPM Sentry Shelf Manager software for system management. Refer to [SAM Software on page 136](#) for further information.

The SAM also provides these operations for the AXP1440 shelf:

- Control for the activation/deactivation of AdvancedTCA blades
- Handles E-Keying
- Control of Power Management
- Monitoring of overall system and blade level health
- Logging for critical system events
- Support for the Command Line Interface (CLI) to access shelf information for:
  - Shelf blade population
  - List of sensors and sensor values
  - Sensor threshold settings

## Shelf Management Alarm Module

---

- System events
- Shelf health
- Control of chassis cooling management (fan levels)

For additional information on the above operations and the Command Line Interface, refer to the *AXP1440/AXP1620 Subsystem IPMI Programmer's Reference* guide and the *Pigeon Point Shelf Manager External Interface Reference* respectively.

## 7.2 Features

The SAM is based on the Pigeon Point Systems ShMM-1500R and Freescale MPC8343 System On a Chip (SOC).

The following lists the features of the SAM.

- High density, small (92 mm x 50.8 mm) form-factor
- Fully compliant with the Restriction of Hazardous Substances (RoHS) directive
- I/O interfaces available on a Tyco 220-pin 0.5 mm Free Height receptacle
- 64, or 128 MBytes of DDR SDRAM with Error Correcting Code (ECC) support
- 266 or 400 MHz PowerPC superscalar RISC core with MMU and caches (32K/32K with parity)
- 32 or 64 MBytes of flash
- Hardware support for a reliable upgrade of software images in flash
- Dual IPMB with IPMB buffer controls for hot insertion and removal onto a live backplane
- Dual serial interface at RS-232 or CMOS levels (one port with modem control)
- Dual 10/100Mbit Ethernet using the integrated 802.3 controllers buffered by external on-board PHY layer devices
- FPGA device on the PCI bus used to implement IPMB-0, the Shelf Manager-oriented interfaces for hardware redundancy, hot swap and carrier ID, plus the ATCA Watchdog and a high-speed serial interface for an alternate software redundancy interface between peer ShMM-1500Rs.
- Three general-purpose I<sup>2</sup>C interfaces (one with limitations) for access to on-carrier devices, such as hardware monitors and the Telco Alarm interface
- RTC, backed by on-carrier battery
- User SEEPROM
- External interrupt inputs



- User GPIO
- SPI interface as an extension interface for on-carrier devices
- PCI interface as an extension interface for on-carrier devices
- On-carrier PLD interface
- JTAG interface for software debug and manufacturing

## 7.3 SAM Diagram and Face Plate Layout

The following figure shows a block diagram of the overall SAM architecture and [Figure 7-2 on page 122](#) shows the face plate layout.

Figure 7-1 Block Diagram of SAM

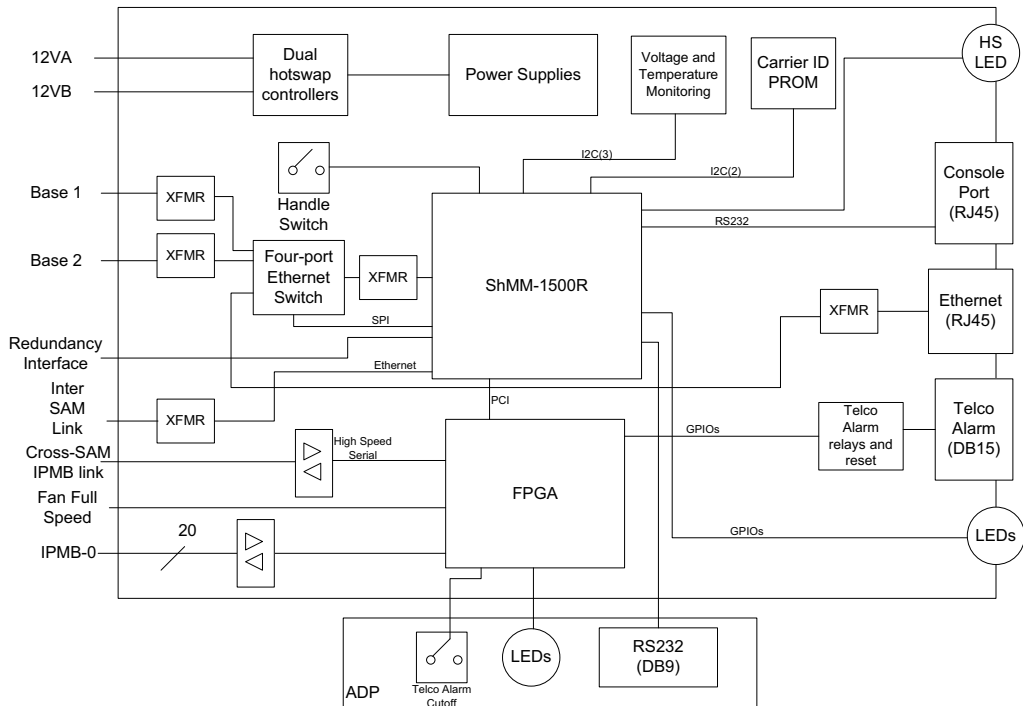

The SAM has these interfaces:

- Four 10/100Base-T Ethernet links
  - One link to each system controller and switching blade (2)
  - One link to the redundant SAM
  - One link to the face plate

## Shelf Management Alarm Module

- One Ethernet link, failover management status signals, and one IPMB branch or segment to the other SAM
- Radial IPMB links for up to 20 modules (16 blades, 2 fan trays, and 2 PEMs)
- Face plate interfaces that include 10/100Base-T Ethernet, RS-232 serial console, and Telco alarm interface with connector
- Interface to ADP panel for Telco Alarm indicators and serial console port

The SAM provides the face plate LEDs listed in the following table. More detail on the LEDs is provided in the following sections.

Figure 7-2 SAM Face Plate

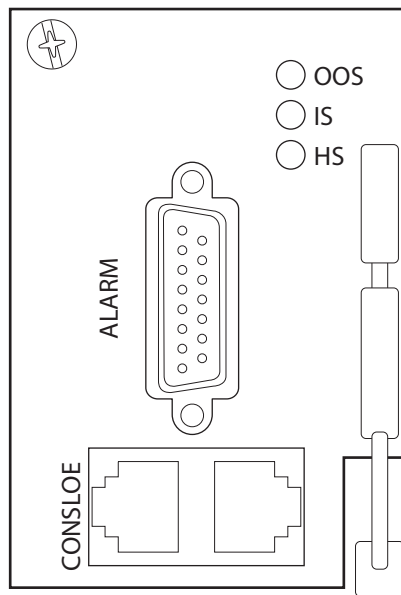

## 7.4 Functional Description

The SAM has a high-density 220 pin socket for the shelf management mezzanine (ShMM) device and front-panel connectors for the serial console, Ethernet, and Telco alarm signals of the mezzanine. The dual-IPMB interface from the mezzanine is connected to the dual IPMBs in the backplane.

The SAM includes several on-board devices that enable different aspects of shelf management based on the shelf management mezzanine. These facilities include I<sup>2</sup>C-based hardware monitoring/control and GPIO expander devices.

## 7.4.1 IPMB Connectivity

The IPMB is a dual radial topology. Each IPMC in the shelf connects to both SAMs for a redundant IPMB.

## 7.4.2 RS-232 Serial Interface

The SAM provides an RS-232 interface on the face plate connector using an RJ-45 connector. The connector is routed to the serial port of the shelf manager mezzanine. The default baud rate is 9600, 8, N, 1. Pin assignments for this connector are:

*Table 7-1 RJ-45 Serial Port Connector*

Pin	Signal	Direction
1	DSR	Input
2	DCD	Input
3	DTR	Output
4	GND	
5	RXD	Input
6	TXD	Output
7	CTS	Input
8	RTS	Output

The SAM provides an RS-232 interface on the alarm display panel at the front of the chassis utilizing a mini-D 9pin connector. The connector is routed to the second serial port of the shelf manager. The baud rate is 115200, 8, N, 1 and cannot be changed. Pin assignments for this connector are:

*Table 7-2 Alarm Display Panel (ADP) Serial Port Connector*

Pin	Signal	Direction
1	No Connect	
2	RXD	Input
3	TXD	Output
4	No Connect	
5	SigGnd	

## Shelf Management Alarm Module

Table 7-2 Alarm Display Panel (ADP) Serial Port Connector (continued)

Pin	Signal	Direction
6	No Connect	
7	No Connect	
8	No Connect	
9	No Connect	

### 7.4.3 Master-Only I<sup>2</sup>C Bus

The SAM provides a number of I<sup>2</sup>C devices using the master-only I<sup>2</sup>C bus of the shelf manager mezzanine. The master-only I<sup>2</sup>C bus is used internally on the mezzanine for the real-time clock and EEPROM devices. Additional I<sup>2</sup>C devices connected to the bus on the SAM are used for the following functions:

- System hardware monitoring and control
- GPIO extension, for various purposes

### 7.4.4 Shelf FRU SEEPROM

The SAM provides access to the SEEPROMS on the Alarm Display Panel (ADP) through the master-only I<sup>2</sup>C. Information stored on the ADP contains Penguin Edge OEM records that enable the SAM to self-configure for the AXP1440 shelf.

### 7.4.5 SAM LEDs

The SAM provides the LEDs listed in the following table. More detail on the LEDs is provided in the following sections. Also refer to [Figure 7-2 on page 122](#) for SAM face plate LED locations and to [Figure 2-1 on page 48](#) for the ADP telco LED locations.

Table 7-3 SAM LEDs

LED	Type	Location
Telco	Critical alarm (CRIT) Major alarm (MAJ) Minor alarm (MIN)	Alarm Display Panel
Power	Power indicator	Alarm Display Panel
In Service	In Service (IS)	SAM face plate

Table 7-3 SAM LEDs (continued)

LED	Type	Location
Out of Service	Out of Service (OOS)	SAM face plate
Hot Swap	Hot swap ready (HS)	SAM face plate

### 7.4.5.1 Hot Swap LED

The SAM provides a blue hot swap LED. This LED indicates when it is safe to remove the SAM from a live shelf.

Table 7-4 Hot Swap LED States

State	Condition
Off	The SAM is not ready to be removed/disconnected from the shelf
Blue	The SAM is ready to be removed/disconnected from the shelf
Long-blink	The SAM is activating itself
Short-blink	Deactivation has been requested

The software running on the shelf manager mezzanine is responsible for turning the LED on/off using the GPIOs on the ShMC.

### 7.4.5.2 SAM/ADP Status LEDs

Status is shown using an LED on the SAM face plate and ADP. The illumination state of the LED is normally controlled by the GPIO on the SAM. The following tables describe the LED states.

Table 7-5 SAM LED Status Indicators

SAM Face Plate LED	LED Color	State	State/Condition
IS (In Service)	Green	On	Active, power good
OOS (Out of Service)	Red	On	Failed
HS (How Swap)	Blue	On	Remove OK

Table 7-6 ADP LED Status Indicators

Alarm Display Panel LED	LED Color	State	State/Condition
Critical alarm (CRT)	Red	On	Active

## Shelf Management Alarm Module

---

Table 7-6 ADP LED Status Indicators (continued)

Alarm Display Panel LED	LED Color	State	State/Condition
Major alarm (MAJ)	Red	On	Active
Minor Alarm (MIN)	Yellow	On	Active
Power (PWR)	Green	On	Power Present

## 7.5 Management and Control

This section gives a general description of the role of the on-board I<sup>2</sup>C devices and how management, control, and redundancy is handled by the SAM. Detailed information on sensors can be found in the *AXP1440/AXP1620 Subsystem IPMI Programmer's Reference*.

### 7.5.1 Hardware Monitoring and Control

The hardware monitoring and control functions implemented by the AXP1440 are provided by the on-board I<sup>2</sup>C-based devices.

#### 7.5.1.1 Voltage Sensors

On-board sensors provide the following power supply voltages. All voltage sensors are implemented using the ADM1024 device on the master-only I<sup>2</sup>C bus. System management software running on the SAM is responsible for reacting to an event when an interrupt is triggered by the ADM1024 device.

#### 7.5.1.2 Temperature Monitoring

An on-board temperature sensor is available on the SAM. This sensor is implemented through the ADM1024.

#### 7.5.1.3 Fan Speed and Control

All fan speed and fan voltage sensors are exposed on the active SAM.

The FTMs have 110 fan speed settings. The SAM uses a proprietary cooling algorithm to automatically adjust the fan speed to cool the chassis based on sensor data from the blades as well as inlet and outlet sensors on the FTMs. The minimum fan speed is 1.

## Shelf Management Alarm Module

In normal operating conditions, the cooling algorithm adjusts the fan speed based on the ambient air temperature as measured at the inlet fans to maintain a **deltaT** value (calculated to be the rise in air temperature measured at the inlet and outlet fan sensors) based on the inlet air temperature value. The lower the ambient temperature, the higher the rise in temperature allowed.



**At least one shelf manager must be in the shelf for proper operation of the cooling algorithm. Removal of both shelf managers results in the fan speed remaining the same and uncontrolled.**

The **deltaT** set point is calculated as follows:

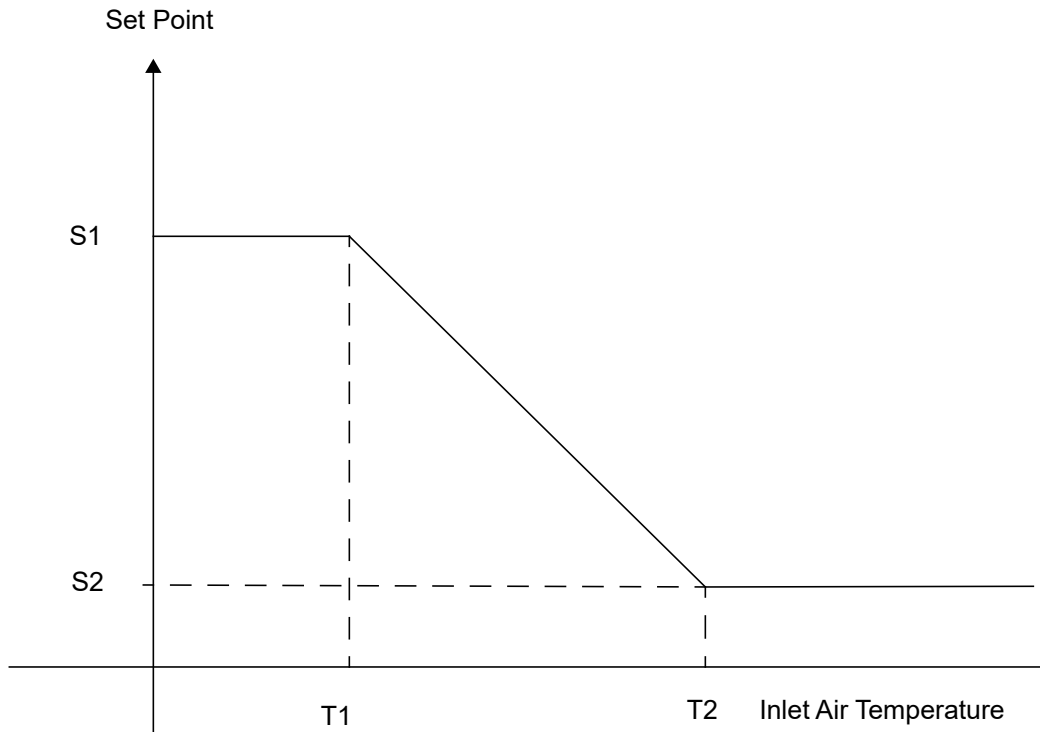

For ambient air temperatures at or below 25°C (default T1), the deltaT set point is set to 20°C (default S1). For ambient air temperatures at or above 55°C (default T2), the deltaT set point is set to 10°C (default S2). For ambient air temperatures between T1 and T2, the deltaT set point is calculated using the following algorithm:

$$S1 + \frac{S2 - S1}{T2 - T1} (T_{inlet} - T1)$$

## Shelf Management Alarm Module

---

Using the above algorithm, at 40°C ambient, the cooling algorithm adjusts the fan speeds to maintain a deltaT rise in temperature at 15°C.

Table 7-7 Cooling Budget

Ambient Temperature	Temperature Rise
25°C	Delta T = 20°C
40°C	Delta T = 15°C
55°C	Delta T = 10°C

The values for S1, S2, T1, and T2 are configurable.

In abnormal operating conditions; that is, when a blade thermal sensor is approaching or crossed its upper non-critical threshold, the SAM automatically adjusts the fan speeds to a point where all the blade thermal sensors are just below their upper non-critical threshold (minus a user configurable offset).

The dynamic minimum fan level is not used.

Each fan tray has six fan units and each fan unit has an inlet and outlet fan. Fan speeds for all level settings are summarized in the next table.

Fan Level	Speed in RPMs
1	1800 Inlet, 1100 Outlet ±10%
10	2600 Inlet, 1500 Outlet ±10%
20	3200 Inlet, 2000 Outlet ±8%
30	3900 Inlet, 2400 Outlet ±8%
40	4500 Inlet, 2900 Outlet ±5%
50	5100 Inlet, 3300 Outlet ±5%
60	5800 Inlet, 3700 Outlet ±5%
70	6400 Inlet, 4200 Outlet ±5%
80	7000 Inlet, 4500 Outlet ±5%
90	7600 Inlet, 5000 Outlet ±5%
100	8000 Inlet, 5200 Outlet ±5%



### 7.5.2 Redundancy Control

The ShMM-1500R supports redundant operation with automatic switchover using a redundant ShMM-1500R. In a configuration where two ShMM-1500Rs are present, one acts as the active shelf manager and the other as a standby. Both ShMM-1500Rs monitor each other, and either can trigger a switchover if necessary.

The ShMM-1500R provides a number of hardware redundancy signals on the CN1 connector. The HRI is implemented using the FPGA device.

## Shelf Management Alarm Module

---

### 7.5.2.1 Hardware Redundancy Interface

The hardware redundancy signals of the ShMM-1500R are implemented as follows:

- Cross connected ShMM-1500R present input (PRES\_R#) and output (PRES\_L#)
- Cross connected ShMM-1500R status 0 input (SHMM\_STATUS0\_R) and output (SHMM\_STATUS0\_L)
- Cross connected redundant ShMM-1500R status 1 input (SHMM\_STATUS1\_R) and output (SHMM\_STATUS1\_L)
- Active output (ACTIVE#) that can be used on the ShMM-1500R carrier to enable interfaces that must be exclusively driven by the active ShMM-1500R
- Bi-color status LED

The ACTIVE# signal is intended for use on a carrier and is not connected directly to the peer-ShMM through the backplane. The cross-connected ShMM-1500R status signals are asynchronous serial bit streams that are transmitted to the peer-ShMM by the FPGA and communicate the following information: Health status, Switchover Requests, PRES\_R state, Active state, watchdog timer status, parity and other TBD data. An identical copy of the bit stream is also sent on the redundant ShMM-1500R status signal. This information is used by the FPGA to ensure that only one of the two connected ShMM-1500Rs goes into active mode at a time. *Figure 7-3 on page 131* shows the HRI of the ShMM-1500R.

As shown in the figure, the ShMM-1500R HRI incorporates a hot-swap buffer (IDT QuickSwitch), which isolates the interface from the peer ShMM prior to FPGA configuration or when the ShMM-1500R is powered down. The QuickSwitch device is guaranteed to be disabled (open) when non-powered and does not have a low impedance path from any of the signal pins to the power or ground rails. Hence, the device prevents a non-powered ShMM-1500R from loading down the HRI of the peer ShMM-1500R. It also prevents a carrier from detecting the ACTIVE# output as a zero; that is, active, during a ShMM-1500R power cycle or a ShMM-1500R power supply failure.

The FPGA device contains a built-in CRC error checker for detecting soft errors in the configuration data. When a CRC error is detected the signal LATCH\_CRC\_ERROR is set active by the ShMM-1500R CRC error detection circuit, which immediately sets the ShMM\_STATUS[0:1]\_L and ACTIVE# signals high. The peer ShMM-1500R, if it is not already active upon detecting the loss of the status serial bit streams, becomes the active ShMM-1500R.

Figure 7-3 SAM HRI Interconnection

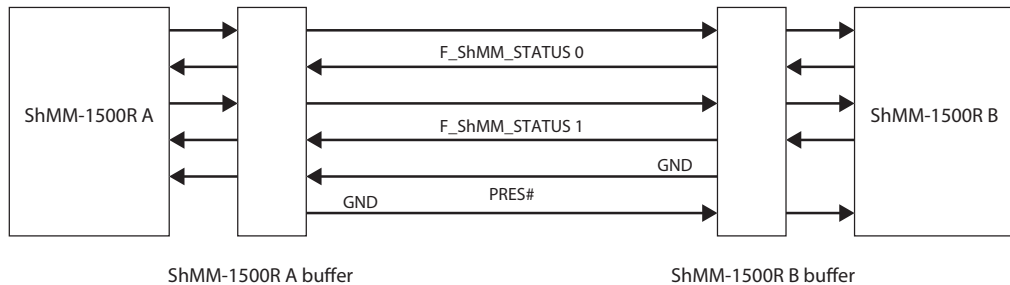

The HRI also includes 13 test points for in-service monitoring of the hardware redundancy signals and for out-of-service diagnostics, enabling the ShMM-1500R to isolate failures on the HRI to a single carrier +ShMM-1500R pair.

### 7.5.2.2 HRI Protocol

In the redundant configuration, the two ShMM-1500R boards communicate through the HRI by exchanging data packets. The HRI continues to be operational in case of a single interconnection failure and is able to detect a double failure. The HRI has a redundant communication path, using four signals. In the case of a single wire permanent failure (the signal gets stuck high, low or breaks), data packets continue to be transmitted through the redundant communication path. A short between two of these four signals is considered a double failure.

### 7.5.2.3 Ethernet Signals

The ShMM1500R provides two 100BaseT Ethernet ports, identified within the Linux environment as eth0 and eth1. The eth0 port is cross-connected to the eth0 port on the other SAM to provide a dedicated high-speed inter-SAM link for the exchange of status and configuration details. The eth1 port is connected to an Ethernet switch (a Broadcom BCM5325E), which in turn connects to the base ports of the two hub slots and to the front-panel RJ-45 Ethernet connector.

## Shelf Management Alarm Module

The port utilization of the switch is:

- TP port 1 to Local hub slot
- TP port 2 to Remote hub slot
- TP port 3 to Front panel RJ-45)
- TP port 4 to ShMM1500R
- TP port 5 is not used
- MII port is not used

The default state of the Ethernet switch is not to forward packets between ports. The correct switch configuration for normal operation is to allow ingress from ports 1, 2 and 3 to port 4 and to allow egress from port 4 to ports 1, 2 and 3. With the exception of routing a port to itself, all other routes are blocked.

Figure 7-4 Interhub Slot and Shelf Manager Connectivity

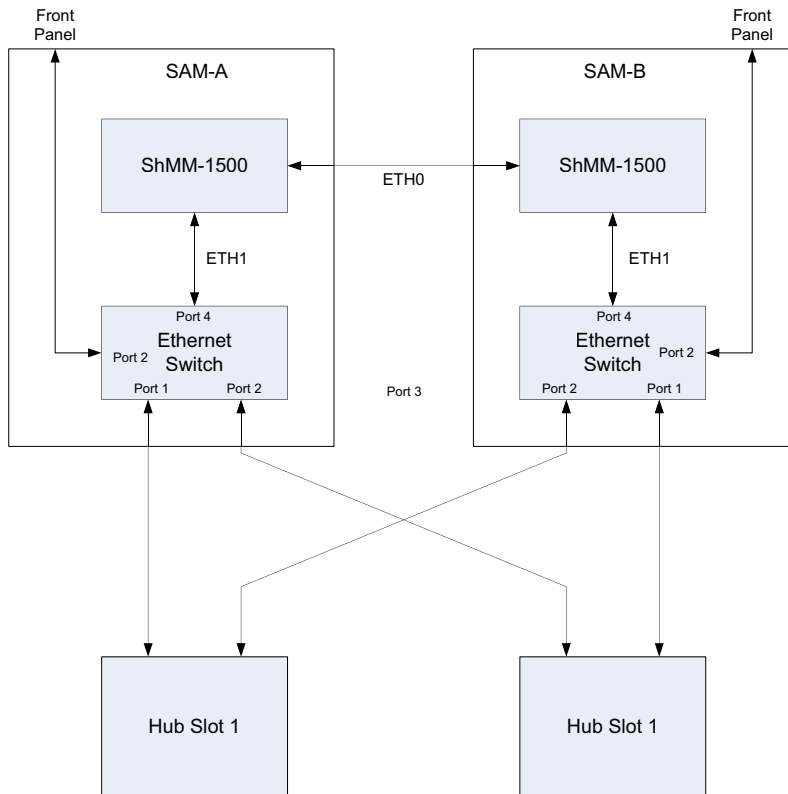

The default configuration of Ethernet channels is depicted in [Table 7-8](#) and [Table 7-9](#).

*Table 7-8 Shelf Manager Static Network IP Interfaces*

Function	IP Active SAM	IP Backup SAM	Ethernet Device	Default State
SAM - SAM	192.168.25.101	192.168.25.100	ETH0	Enabled
Front Panel RJ-45	0.0.0.0	0.0.0.0	ETH1	Disabled
SAM to Hub	192.168.24.101	192.168.24.100	ETH1.24	Enabled

*Table 7-9 Shelf Manager Dynamic Network IP Interfaces*

Function	IP Active SAM	IP Backup SAM	Ethernet Device	Default State
RMCP	192.168.24.11	192.168.24.10	ETH1.24:1	Enabled

### NOTICE

The IP addresses defined in [Table 7-9](#) are relative to active/standby SAM. When active/standby switchover takes place the addresses are re-assigned to the appropriate physical SAMs. Addresses ending in '1' are always associated with the active SAM. Addresses ending in '0' are always associated with the standby.

#### 7.5.2.4 Configuring Front Panel Network Interface

To set front panel Ethernet and make it permanent over power cycle set the following U-boot environment variables. This may be done in Linux or U-Boot. If done in U-Boot, `saveenv` must be executed to save the environment variables.

```
setenv ip1addr <IP address>
setenv gatewayip <gateway IP>
setenv enable_front_panel_ethernet y
saveenv
```

#### 7.5.2.5 Configuring RMCP Network Interface

To change the RMCP network address that is associated with the Active and Standby Shelf managers from the default values, use the following `cli` command on the Active Shelf Manager, where `xxx.xxx.xxx.xxx` indicates a sample IP address.

```
cli setlanconfig 1 3 xxx.xxx.xxx.xxx
```

## Shelf Management Alarm Module

---

This sets the floating RCMP IP address associated with the Active Shelf Manager specified by the IP address supplied in the command. The Standby Shelf Manager floating RCMP address will be the exclusive-OR of the least significant bit of that address. If the IP address assigned with the setlanconfig is odd, the Standby Shelf Manager floating RCMP IP address will be 1 less than the active. If the RCMP IP address for the Active Shelf Manager is even, then the RCMP IP address for the Standby Shelf Manager will be greater by 1. For information on configuration of additional characteristics of the RCMP interface, like subnet address and so on, refer to *Pigeon Point Shelf Manager External Interface Reference*.

### 7.5.3 Switchover Signals

A switchover takes place when the Standby SAM determines that the Active SAM is no longer operational. The signs of this are:

**The REMOTE\_HEALTHY or REMOTE\_PRESENT changes to FALSE.**

This indicates that the peer SAM is no longer healthy or present

**The TCP connection between the Active and the Standby SAMS closes.**

The keep alive time-out parameter for this connection is set to 1 second to recognize a malfunction of the Active SAM as quickly as possible. In this case the Standby SAM waits for 3 seconds and then checks the state of the REMOTE\_HEALTHY to make sure the connection is broken due to a failure of the Active SAM and not due to a communication failure.

If the Standby SAM detects that the Active SAM is still healthy it doesn't perform the switchover but instead reboots itself. After the reboot it makes a second attempt to initialize as a backup and will continue until it succeeds in establishing the connection with the Active SAM or it detects that the Active SAM is no longer healthy. If it detects that it isn't healthy it will initialize as the Active SAM.

**When the Active SAM receives a switchover command from the Standby SAM and agrees to switchover.**

The Active SAM closes the TCP connection, clears the LOCAL\_HEALTHY bit and exits the program which indicates the switchover to the Standby SAM.

If the Standby SAM decides that a switchover should take place it closes the TCP connection and exits this function. Activate callbacks are called for all facilities and the SAM starts to work in active mode, with no backup. At this moment the SAM sets the LOCAL\_SWITCHOVER bit, requesting the hardware to recognize it as the Active SAM. In response, the hardware must set the ACTIVE bit. When the formerly active SAM restarts it successfully establishes the connection with the current SAM and starts to operate in the backup mode.

## 7.6 Telco Alarm Functionality

The SAM provides Telco alarm functionality with the following components:

- Telco alarm cutoff push button
- DB15 Telco alarm contacts
- Telco alarm LEDs

### 7.6.1 Telco Alarm Cutoff Push Button

The SAM provides a Telco alarm cutoff function with the front-panel push button switch located on the ADP. This push button activates the alarm cutoff (ACO) state. When ACO is activated, the active alarm LED blinks and all of the alarm relays are deactivated. This button does not clear alarms. Refer to [Figure 7-2 on page 122](#) for the location of the alarm cutoff push button switch.

### 7.6.2 Telco Alarm LEDs

These LEDs are used to indicate the presence of the critical, major, and minor alarms. When a LED is lit, the respective alarm is active. A blinking LED signals an alarm cut-off state which is initiated by pressing the alarm cut-off button when an alarm is active.

### 7.6.3 Telco Alarm Interface

The SAM provides a front-panel alarm connector, which is a standard DB-15 connector with the following pin assignments:

*Table 7-10 Hot Swap Interface Pin Out*

Pin	Description
1	Minor Alarm Reset +
2	Minor Alarm Reset -
3	Major Alarm Reset +
4	Major Alarm Reset -
5	Critical Alarm - NO
6	Critical Alarm - NC
7	Critical Alarm - COM

## Shelf Management Alarm Module

---

Table 7-10 Hot Swap Interface Pin Out (continued)

Pin	Description
8	Minor Alarm - NO
9	Minor Alarm - NC
10	Minor Alarm - COM
11	Major Alarm - NO
12	Major Alarm - NC
13	Major Alarm - COM
14	Pwr Alarm - NO
15	Pwr Alarm - COM

### 7.7 Hot Swap Interface

The SAM provides a hot swap interface allowing the SAM to be replaced without powering down the shelf. The hot swap interface is implemented using the shelf manager mezzanine CPLD device. The interface is composed of three components:

- Injector/ejector handle switch
- Presence signal indicating that the SAM is fully seated in its backplane connector
- HS LED to indicate safe to remove state

### 7.8 Power

The SAM uses dual +12V power feeds, one from each PEM. Hot swap circuitry ensures correct operation when a SAM is inserted into or removed from a live system.

### 7.9 SAM Software

The software that runs on the shelf manager is described in detail in the *Pigeon Point Systems IPM Sentry Shelf Manager User Guide*, which provides an introduction to shelf management, the shelf manager, and the shelf management mezzanine. Also available is the *Pigeon Point Systems IPM Sentry Shelf-External Interface Reference* which describes the command line, web, SNMP (Simple Network Management Protocol), and RMCP



(Remote Management Control Protocol) interfaces. Refer to [Appendix A](#) for more information on these publications.

### 7.9.1 imls Utility

A utility called `imls` is available on the SAM. It can be used to list all firmware images present in flash. Note that the Shelf Manager flash is divided into two banks. Each bank contains a set of three separate firmware images:

- U-Boot
- RFS
- Kernel images

When the `rupgrade_tool` utility is used to perform a reliable firmware upgrade operation on the Shelf Manager, the flash bank that is currently not active is programmed with the new images, the processor is reset, and the newly programmed flash bank is selected.

If the new firmware fails to load or execute properly, the Shelf Manager automatically resets and reverts to the previous flash bank. Selection of the bank to be used for booting is not a configurable option at run-time.

The following text shows sample output obtained by running `imls` at the Shelf Manager Linux prompt. Note that the first three images listed reflect the currently active flash bank contents, and the next set of three images is contained within the other flash bank.

```
# imls
/dev/mtdblock3:
Image Name:   U-Boot 1.1.4 for shmm1500 board
Created:      Fri Jun  6 14:51:44 2008
Image Type:   PowerPC Linux Firmware (uncompressed)
Data Size:    212992 Bytes = 208.00 kB = 0.20 MB
Load Address: 0xF0000000
Entry Point:  0x00000000

/dev/mtdblock2:
Image Name:   Linux-2.4.25
Created:      Fri Jun  6 14:59:00 2008
Image Type:   PowerPC Linux Kernel Image (gzip compressed)
Data Size:    793193 Bytes = 774.60 kB = 0.76 MB
Load Address: 0x00000000
Entry Point:  0x00000000
```

## Shelf Management Alarm Module

---

```
/dev/mtdblock4:
Image Name:  shelfman 4.0.0 build 21
Created:    Fri Jun  6 15:07:27 2008
Image Type: PowerPC Linux RAMDisk Image (gzip compressed)
Data Size:  5398657 Bytes = 5272.13 kB = 5.15 MB
Load Address: 0x00000000
Entry Point: 0x00000000

/dev/mtdblock8:
Image Name:  U-Boot 1.1.4 for shmm1500 board
Created:    Thu Mar 27 21:27:47 2008
Image Type: PowerPC Linux Firmware (uncompressed)
Data Size:  212992 Bytes = 208.00 kB = 0.20 MB
Load Address: 0xF0000000
Entry Point: 0x00000000

/dev/mtdblock7:
Image Name:  Linux-2.4.25
Created:    Thu Mar 27 21:33:51 2008
Image Type: PowerPC Linux Kernel Image (gzip compressed)
Data Size:  793096 Bytes = 774.51 kB = 0.76 MB
Load Address: 0x00000000
Entry Point: 0x00000000

/dev/mtdblock9:
Image Name:  sentry.shmm1500 RFS Ramdisk Imag
Created:    Thu Mar 27 21:41:21 2008
Image Type: PowerPC Linux RAMDisk Image (gzip compressed)
Data Size:  5429028 Bytes = 5301.79 kB = 5.18 MB
Load Address: 0x00000000
Entry Point: 0x00000000
#
```

From the sample output, it is possible to see the compilation dates of the U-Boot, RFS, and Kernel images for both the active and nonactive firmware banks. Compilation times are never identical for all three images, but should be relatively close to each other.

# Related Documentation

## A.1 Penguin Solutions Documentation

Technical documentation can be found by using the Documentation Search at <https://www.penguinsolutions.com/edge/support/> or you can obtain electronic copies of documentation by contacting your local Penguin Solutions sales representative.

*Table A-1 Penguin Solutions Documentation*

Document Title	Document Number
AXP1440 Data Sheet	AXP1440-DS
AXP1440 Release 1.0 Document Collection	6806800H24
AXP1440/AXP1620 Subsystem IPMI Programmer's Reference	6806800G38
AXP1440 Release Notes	6806800H23
AXP1440-C06 Installation and Use	6806800U21
AXP1440-C07 Installation and Use	6806800V18
ATCA-F140 Installation and Use	6806800M67
ATCA-F140: Control through IPMI Programmer's Reference	6806800R08
System Management Interface Based on HPI-B (AXP1620/1440) User's Guide	6806800D85

## A.2 Related Specifications

For additional information, refer to the following table for related specifications. As an additional help, a source for the listed document is provided. Please note that, while these sources have been verified, the information is subject to change without notice.

*Table A-2 Related Specifications*

Document Title and Source	Publication Number
IEEE <a href="http://standards.ieee.org/catalog/">http://standards.ieee.org/catalog/</a>	
IEEE Standard for Local Area Networks: Carrier Sense Multiple Access with Collision Detection (CSMA/CD) Access Method and Physical Layer Specifications Institute of Electrical and Electronics Engineers, Inc.	IEEE 802.3 March 2002

## Related Documentation

---

*Table A-2 Related Specifications (continued)*

<b>Document Title and Source</b>	<b>Publication Number</b>
Pigeon Point Shelf Manager User Guide <a href="http://www.pigeonpoint.com/library.html">http://www.pigeonpoint.com/library.html</a>	
Pigeon Point Shelf Manager External Interface Reference <a href="http://www.pigeonpoint.com/library.html">http://www.pigeonpoint.com/library.html</a>	
IEEE Amendment 1: Media Access Control parameters, Physical Layers, and Management Parameters for 10Gb/s Operation	IEEE 802.3ae August 2002
PCI Industrial Manufacturers Group (PICMG) <a href="http://www.picmg.com/">http://www.picmg.com/</a>	
PICMG 3.0 AdvancedTCA Base Specification, Revision 1.0	PICMG 3.0 R 1.0 December 30, 2002
PICMG 3.0 AdvancedTCA Serial Interconnect Specification R2.0	PICMG 3.0, R2.0
PICMG 3.1 AdvancedTCA Ethernet/Fibre Channel, Revision 1.0	PICMG 3.1 R1.0 January 22, 2003
PICMG 3.0 ECN 3.0-1.0-001	January 21, 2004 ECN 3.0, 1.0-001



# PENGUIN<sup>™</sup>

SOLUTIONS 

Penguin Solutions is a trade name used by SMART Embedded Computing, Inc., a wholly owned subsidiary of SMART Global Holdings, Inc. Penguin Edge is a trademark owned by Penguin Computing, Inc., a wholly owned subsidiary of SMART Global Holdings, Inc. PICMG, ATCA and AdvancedTCA are trademarks of PICMG. All other logos, trade names, and trademarks are the property of their respective owners.  
©2022 SMART Embedded Computing, Inc.