



Penguin Edge™ XMCspan

Installation and Use

P/N: 6806800H03E

July 2022



Legal Disclaimer*

SMART Embedded Computing, Inc. (SMART EC), dba Penguin Solutions™, assumes no responsibility for errors or omissions in these materials. **These materials are provided "AS IS" without warranty of any kind, either expressed or implied, including but not limited to, the implied warranties of merchantability, fitness for a particular purpose, or non-infringement.** SMART EC further does not warrant the accuracy or completeness of the information, text, graphics, links, or other items contained within these materials. SMART EC shall not be liable for any special, indirect, incidental, or consequential damages, including without limitation, lost revenues or lost profits, which may result from the use of these materials. SMART EC may make changes to these materials, or to the products described therein, at any time without notice. SMART EC makes no commitment to update the information contained within these materials.

Electronic versions of this material may be read online, downloaded for personal use, or referenced in another document as a URL to a SMART EC website. The text itself may not be published commercially in print or electronic form, edited, translated, or otherwise altered without the permission of SMART EC.

It is possible that this publication may contain reference to or information about SMART EC products, programming, or services that are not available in your country. Such references or information must not be construed to mean that SMART EC intends to announce such SMART EC products, programming, or services in your country.

Limited and Restricted Rights Legend

If the documentation contained herein is supplied, directly or indirectly, to the U.S. Government, the following notice shall apply unless otherwise agreed to in writing by SMART EC.

Use, duplication, or disclosure by the Government is subject to restrictions as set forth in subparagraph (b)(3) of the Rights in Technical Data clause at DFARS 252.227-7013 (Nov. 1995) and of the Rights in Noncommercial Computer Software and Documentation clause at DFARS 252.227-7014 (Jun. 1995).

SMART Embedded Computing, Inc., dba Penguin Solutions

2900 S. Diablo Way, Suite 190

Tempe, Arizona 85282

USA

*For full legal terms and conditions, visit <https://www.penguinsolutions.com/edge/legal/>

Table of Contents

About this Manual	9
Safety Notes	13
Sicherheitshinweise	17
1 Introduction	21
1.1 Overview	21
1.2 Features	21
1.3 Standard Compliances	22
1.4 Ordering and Support Information	23
2 Hardware Preparation and Installation	25
2.1 Overview	25
2.1.1 Environmental Considerations	25
2.2 Power Requirements	26
2.2.1 Backplane Power Requirements	27
2.3 Checking the Box Contents	27
2.4 Installing a Mezzanine Card	28
2.5 Installing the Primary XMCspan	30
2.6 Installing the Secondary XMCspan	32
2.7 Removing the XMCspan	34
3 Resetting the XMCspan	35
3.1 Reset Sources	35
4 Controls, LEDs, and Connectors	37
4.1 Overview	37
4.2 Board Layout	37
4.3 Face Plate	38
4.4 Connectors	40
4.4.1 VME Connectors	40
4.4.2 LED Information	42

Table of Contents

5	Functional Description	45
5.1	Overview	45
5.2	Block Diagram	45
5.3	PEX8533 PCI Express Switch	46
5.4	PEX8533 Station and Port Configuration	46
5.5	XMCspan Stacking	46
5.6	Mezzanine Card Sites	46
5.7	Mezzanine Card Identification	47
5.8	XMC.3 Support	47
5.9	PMC AND PRPMC Support	47
5.10	PCI Buses	47
5.11	TSI384 PCI EXPRESS-TO-PCI/PCI-X Bridge	48
5.12	Serial EEPROM For VPD	48
5.13	Clocking Scheme	49
5.14	Debugging Support	49
A	Related Documentation	51
A.1	Penguin Solutions Documentation	51
A.2	Manufacturers' Documents	51
A.3	Related Specifications	52

List of Figures

Figure 4-1	Board Layout	37
Figure 4-2	XMCspan with SCANBE Handles	38
Figure 4-3	XMCspan with IEEE Handles	39
Figure 5-1	XMCspan Block Diagram	45

List of Figures

List of Tables

Table 1-1	Standard Compliances	22
Table 2-1	Environmental	26
Table 2-2	Power Requirements	26
Table 2-3	Backplane Power Requirements	27
Table 4-1	Connector Pin-outs	40
Table 4-2	Pin definition for VME connector P2	40
Table 4-3	PEX 8533 PCIE Switch	42
Table 4-4	Tsi384 PCIE-PCIX PMC2	43
Table 5-1	I2C Bus Address Map	48
Table 5-2	Clocking Scheme	49
Table 5-3	Debugging Support	49
Table A-1	Penguin Edge Documentation	51
Table A-2	Manufacturers' Documentation	51
Table A-3	Related Specifications	52

List of Tables

About this Manual

Overview of Contents

This manual describes how to install the mezzanine cards supported by the XMCspan, and how to install the XMCspan on the VME base board.



Abbreviations





This document uses the following abbreviations:

Abbreviation	Definition
CPLD	Complex Programmable Logic Device
EEPROM	Electrically Erasable Programmable Read-Only Memory
IEEE	Institute of Electrical and Electronics Engineers
JTAG	Joint Test Access Group
PCI	Peripheral Component Interconnect
PCIE	PCI Express
PCI-X	Peripheral Component Interconnect-X
PMC	PCI Mezzanine Card
PrPMC	Processor PMC
RFU	Reserved for future use
SerDes	Serializer/Deserializer
VITA	VMEbus International Trade Association
VME	Versa Module Eurocard
VPD	Vital Product Data
XMC	Switched Mezzanine Card

Conventions

The following table describes the conventions used throughout this manual.

Notation	Description
0x00000000	Typical notation for hexadecimal numbers (digits are 0 through F), for example used for addresses and offsets
0b0000	Same for binary numbers (digits are 0 and 1)
bold	Used to emphasize a word
Screen	Used for on-screen output and code related elements or commands. Sample of Programming used in a table (9pt)
Courier + Bold	Used to characterize user input and to separate it from system output
<i>Reference</i>	Used for references and for table and figure descriptions
File > Exit	Notation for selecting a submenu
<text>	Notation for variables and keys
[text]	Notation for software buttons to click on the screen and parameter description
...	Repeated item for example node 1, node 2, ..., node 12
.	Omission of information from example/command that is not necessary at the time
..	Ranges, for example: 0..4 means one of the integers 0,1,2,3, and 4 (used in registers)
	Logical OR
	Indicates a hazardous situation which, if not avoided, could result in death or serious injury
	Indicates a hazardous situation which, if not avoided, may result in minor or moderate injury

Notation	Description
	Indicates a property damage message
	Indicates a hot surface that could result in moderate or serious injury
	Indicates an electrical situation that could result in moderate injury or death
<p>Use ESD protection</p> 	Indicates that when working in an ESD environment care should be taken to use proper ESD practices
	No danger encountered, pay attention to important information

Summary of Changes

This manual has been revised and replaces all prior editions.

Part Number	Publication Date	Description
6806800H03A	September 2008	First Edition
6806800H03B	November 2013	Added section 4.4 LED Information in Chapter 4.
6806800H03C	June 2014	Rebrandeto Artesyn template.
6806800H03D	December 2019	Rebrand to SMART Embedded Computing template.Declaration of Conformity removed.Updated Ordering Information and Documentation.
6806800H03E	July 2022	Rebrand to Penguin Solutions.

Safety Notes

This section provides warnings that precede potentially dangerous procedures throughout this manual. Instructions contained in the warnings must be followed during all phases of operation, service, and repair of this equipment. You should also employ all other safety precautions necessary for the operation of the equipment in your operating environment. Failure to comply with these precautions or with specific warnings elsewhere in this manual could result in personal injury or damage to the equipment.

Penguin Solutions™ intends to provide all necessary information to install and handle the product in this manual. Because of the complexity of this product and its various uses, we do not guarantee that the given information is complete. If you need additional information, ask your Penguin Solutions representative.

This product is a Safety Extra Low Voltage (SELV) device designed to meet the EN60950-1 requirements for Information Technology Equipment. The use of the product in any other application may require safety evaluation specific to that application.

Only personnel trained by Penguin Solutions or persons qualified in electronics or electrical engineering are authorized to install, remove or maintain the product.

The information given in this manual is meant to complete the knowledge of a specialist and must not be used as replacement for qualified personnel.

Keep away from live circuits inside the equipment. Operating personnel must not remove equipment covers. Only Factory Authorized Service Personnel or other qualified service personnel may remove equipment covers for internal subassembly or component replacement or any internal adjustment.

Do not install substitute parts or perform any unauthorized modification of the equipment or the warranty may be voided. Contact your local Penguin Solutions representative for service and repair to make sure that all safety features are maintained.

EMC

This equipment has been tested and found to comply with the limits for a Class A digital device, pursuant to Part 15 of the FCC Rules. These limits are designed to provide reasonable protection against harmful interference when the equipment is operated in a commercial environment. This equipment generates, uses, and can radiate radio frequency energy and, if not installed and used in accordance with the instruction manual, may cause harmful interference to radio communications.

Operation of this equipment in a residential area is likely to cause harmful interference in which case the user will be required to correct the interference at his own expense. Changes or modifications not expressly approved by Penguin Solutions could void the user's authority to operate the equipment.

Safety Notes

Board products are tested in a representative system to show compliance with the above mentioned requirements. A proper installation in a compliant system will maintain the required performance. Use only shielded cables when connecting peripherals to assure that appropriate radio frequency emissions compliance is maintained.

Operation

Product Damage

High humidity and condensation on the board surface causes short circuits.

Do not operate the board outside the specified environmental limits.

Make sure the board is completely dry and there is no moisture on any surface before applying power.

Damage of Circuits

Electrostatic discharge and incorrect installation and removal can damage circuits or shorten their life.

Before touching the board or electronic components, make sure that you are working in an ESD-safe environment.

Installation

Data Loss

Powering down or removing a board before the operating system or other software running on the board has been properly shut down may cause corruption of data or file systems.

Make sure all software is completely shut down before removing power from the board or removing the board from the chassis.

Product Damage

Only use injector handles for board insertion to avoid damage to the front panel and/or PCB. Deformation of the front panel can cause an electrical short or other board malfunction.

Product Damage

Inserting or removing modules with power applied may result in damage to module components.

Before installing or removing additional devices or modules, read the documentation that came with the product.

Environment

Improper disposal of used products may harm the environment. Always dispose of used products according to your country's legislation and manufacturer's instructions.

Safety Notes

Sicherheitshinweise

Dieses Kapitel enthält Hinweise, die potentiell gefährlichen Prozeduren innerhalb dieses Handbuchs vorrangestellt sind. Beachten Sie unbedingt in allen Phasen des Betriebs, der Wartung und der Reparatur des Systems die Anweisungen, die diesen Hinweisen enthalten sind. Sie sollten außerdem alle anderen Vorsichtsmaßnahmen treffen, die für den Betrieb des Produktes innerhalb Ihrer Betriebsumgebung notwendig sind. Wenn Sie diese Vorsichtsmaßnahmen oder Sicherheitshinweise, die an anderer Stelle dieses Handbuchs enthalten sind, nicht beachten, kann das Verletzungen oder Schäden am Produkt zur Folge haben.

Penguin Solutions™ ist darauf bedacht, alle notwendigen Informationen zum Einbau und zum Umgang mit dem Produkt in diesem Handbuch bereit zu stellen. Da es sich jedoch um ein komplexes Produkt mit vielfältigen Einsatzmöglichkeiten handelt, können wir die Vollständigkeit der im Handbuch enthaltenen Informationen nicht garantieren. Falls Sie weitere Informationen benötigen sollten, wenden Sie sich bitte an die für Sie zuständige Geschäftsstelle von Penguin Solutions.

Das Produkt wurde entwickelt, um die Sicherheitsanforderungen für SELV Geräte nach der Norm EN 60950-1 für informationstechnische Einrichtungen zu erfüllen. Die Verwendung des Produkts in einer anderen Anwendung erfordert eine Sicherheitsüberprüfung für diese spezifische Anwendung.

Einbau, Wartung und Betrieb dürfen nur von durch Penguin Solutions ausgebildetem oder im Bereich Elektronik oder Elektrotechnik qualifiziertem Personal durchgeführt werden. Die in diesem Handbuch enthaltenen Informationen dienen ausschließlich dazu, das Wissen von Fachpersonal zu ergänzen, können dieses jedoch nicht ersetzen.

Halten Sie sich von stromführenden Leitungen innerhalb des Produktes fern. Entfernen Sie auf keinen Fall Abdeckungen am Produkt. Nur werksseitig zugelassenes Wartungspersonal oder anderweitig qualifiziertes Wartungspersonal darf Abdeckungen entfernen, um Komponenten zu ersetzen oder andere Anpassungen vorzunehmen.

Installieren Sie keine Ersatzteile oder führen Sie keine unerlaubten Veränderungen am Produkt durch, sonst verfällt die Garantie. Wenden Sie sich für Wartung oder Reparatur bitte an die für Sie zuständige Geschäftsstelle von Penguin Solutions. So stellen Sie sicher, dass alle sicherheitsrelevanten Aspekte beachtet werden.

EMV

Das Produkt wurde in einem Penguin Edge™ Standardsystem getestet. Es erfüllt die für digitale Geräte der Klasse A gültigen Grenzwerte in einem solchen System gemäß den FCC-Richtlinien Abschnitt 15 bzw. EN 55022 Klasse A. Diese Grenzwerte sollen einen angemessenen Schutz vor Störstrahlung beim Betrieb des Produktes in Gewerbe- sowie Industriegebieten gewährleisten.

Sicherheitshinweise

Das Produkt arbeitet im Hochfrequenzbereich und erzeugt Störstrahlung. Bei unsachgemäßem Einbau und anderem als in diesem Handbuch beschriebenen Betrieb können Störungen im Hochfrequenzbereich auftreten.

Wird das Produkt in einem Wohngebiet betrieben, so kann dies mit grosser Wahrscheinlichkeit zu starken Störungen führen, welche dann auf Kosten des Produktanwenders beseitigt werden müssen. Änderungen oder Modifikationen am Produkt, welche ohne ausdrückliche Genehmigung von Penguin Solutions durchgeführt werden, können dazu führen, dass der Anwender die Genehmigung zum Betrieb des Produktes verliert. Boardprodukte werden in einem repräsentativen System getestet, um zu zeigen, dass das Board den oben aufgeführten EMV-Richtlinien entspricht. Eine ordnungsgemässe Installation in einem System, welches die EMV-Richtlinien erfüllt, stellt sicher, dass das Produkt gemäss den EMV-Richtlinien betrieben wird. Verwenden Sie nur abgeschirmte Kabel zum Anschluss von Zusatzmodulen. So ist sichergestellt, dass sich die Aussendung von Hochfrequenzstrahlung im Rahmen der erlaubten Grenzwerte bewegt.

Warnung! Dies ist eine Einrichtung der Klasse A. Diese Einrichtung kann im Wohnbereich Funkstörungen verursachen. In diesem Fall kann vom Betreiber verlangt werden, angemessene Massnahmen durchzuführen.

Betrieb

Beschädigung des Produktes

Hohe Luftfeuchtigkeit und Kondensat auf der Oberfläche des Produktes können zu Kurzschlüssen führen.

Betreiben Sie das Produkt nur innerhalb der angegebenen Grenzwerte für die relative Luftfeuchtigkeit und Temperatur. Stellen Sie vor dem Einschalten des Stroms sicher, dass sich auf dem Produkt kein Kondensat befindet.

Beschädigung von Schaltkreisen

Elektrostatische Entladung und unsachgemäßer Ein- und Ausbau des Produktes kann Schaltkreise beschädigen oder ihre Lebensdauer verkürzen.

Bevor Sie das Produkt oder elektronische Komponenten berühren, vergewissern Sie sich, daß Sie in einem ESD-geschützten Bereich arbeiten.

Installation

Datenverlust

Das Herunterfahren oder die Deinstallation eines Boards bevor das Betriebssystem oder andere auf dem Board laufende Software ordnungsmässig beendet wurde, kann zu partiellem Datenverlust sowie zu Schäden am Filesystem führen.

Stellen Sie sicher, dass sämtliche Software auf dem Board ordnungsgemäss beendet wurde, bevor Sie das Board herunterfahren oder das Board aus dem Chassis entfernen.

Beschädigung des Produktes

Fehlerhafte Installation des Produktes kann zu einer Beschädigung des Produktes führen.

Verwenden Sie die Handles, um das Produkt zu installieren/deinstallieren. Auf diese Weise vermeiden Sie, dass das Face Plate oder die Platine deformiert oder zerstört wird.

Beschädigung des Produktes und von Zusatzmodulen

Fehlerhafte Installation von Zusatzmodulen, kann zur Beschädigung des Produktes und der Zusatzmodule führen.

Lesen Sie daher vor der Installation von Zusatzmodulen die zugehörige Dokumentation.

Umweltschutz

Unsachgemäße Entsorgung von gebrauchten Produkten kann die Umwelt schädigen. Entsorgen Sie gebrauchte Produkte stets gemäß der in Ihrem Land gültigen Gesetzgebung und den Empfehlungen des Herstellers.

Introduction

1.1 Overview

This chapter gives an overview of the features of the XMCspan, lists the standard compliances, and details the ordering information for the board.

1.2 Features

The XMCspan is a carrier module that provides PCI Express expansion capability to the VME base board.

The XMCspan has the following features:

- Provides access to XMC/PMC I/O through the front panel or rear transition module
- Provides stacking capability for up to two XMCspan modules
- Compatibility with the MVME7100 board
- Compatibility with the MVME7100 board
- Support for two single-wide XMC/PMC/PrPMC modules, or one double-width XMC/PMC/PrPMC module
- +3.3V PCI signaling voltage (VIO)
- PEX8533 PCI Express switch with the following features:
 - Six highly flexible and configurable PCI Express ports
 - 32 full duplex PCI Express lanes with integrated SerDes
 - 2.5Gbps bandwidth per lane
 - Fully non-blocking switch architecture
 - Signal support for INTA and FATAL ERROR
 - Support for QoS (Quality of Service)
 - Support for port performance monitoring
- Tsi384 PCI Express-to-PCI/PCI-X bridge with the following features:
 - Four full duplex PCI Express lanes with integrated SerDes
 - 2.5 Gbps bandwidth per lane
 - Conventional PCI data rates: 33 and 66MHz
 - PCI-X data rates: 50, 66, 100, and 133MHz

1.3 Standard Compliances

This product meets the following standards compliances:

Table 1-1 Standard Compliances

Standard	Description
UL 60950-1 UL 94V-011 EN 60950-1 IEC 60950-1 CAN/CSA C22.2 No. 60950-1	Safety requirements
SN29500/8 MIL-HDBK-217F	Reliability requirements
IEC 68-2-1/2/3/13/14	Climatic environmental requirements. The XMCspan can only be used in a restricted temperature range.
IEC 68-2-6/27/32	Mechanical environmental requirements.
EN 50081-1 EN 50082-2 FCC Part 15 Class B EN 300 386 EN 55022 EN 55024 NEBS Standard GR-1089-CORE	EMC requirements on system level.
ANSI/IPC-A-610 Rev.B Class 2 ANSI/IPC-R-700B ANSI-J-001 ANSI-J-002 ANSI-J-003	Manufacturing requirements
ISO 8601	Y2K compliance
NEBS Standard GR-63-CORE ETSI EN 300019 series	Environmental requirements

1.4 Ordering and Support Information

Refer to the data sheet for the XMCspan for a complete list of available variants and accessories. Refer to [Appendix A, Related Documentation](#) or consult your local SPenguin Solutions™ sales representative for the availability of other variants.

For technical assistance, documentation, or to report product damage or shortages, contact your local Penguin Solutions sales representative or visit <https://www.penguinsolutions.com/edge/support/>.

Hardware Preparation and Installation

2.1 Overview

This chapter discusses the installation of a mezzanine card and XMCspan module.

The following procedures are detailed:

- [Installing a Mezzanine Card on page 28](#)
- [Installing the Primary XMCspan on page 30](#)
- [Installing the Secondary XMCspan on page 32](#)
- [Removing the XMCspan on page 34](#)

2.1.1 Environmental Considerations

The following environmental conditions must be tested and proven in the used system configuration. These conditions refer to the surroundings of the board within the user environment.

NOTES:

- Operating temperatures refer to the temperature of the air circulating around the module and not to the component temperature.
- Forced air cooling within the system is required to make sure that the operating conditions are met.
- The environmental values listed in the table only apply to the board without any accessories. If you install accessories, you must consider their environmental requirements.

NOTICE

High humidity and condensation on the surface of the board causes short circuits. Do not operate the board outside the specified environmental limits. Make sure the board is completely dry and there is no moisture on any surface before applying power.

Hardware Preparation and Installation

Table 2-1 Environmental

Requirement	Operating	Non-Operating
Temperature	0°C (32°F) to +55°C (+131°F) This may be limited by the type of hard disk used.	-40°C (-40°F) to +85°C (+185°F)
Temperature Change	±0.5°C/min	±1°C/min
Forced Air Flow	-	-
Relative Humidity	5% to 95% non-condensing at +40°C (+104°F)	5% to 95% non-condensing at +40°C (+104°F)
Altitude	-300m to 3,000m	-300m to 13000m
Vibration	0.1g from 5 to 100 Hz and back to 5Hz at a rate of 0.1 octave/minute	5-20 Hz at 0.01 g2/Hz 20-200 Hz at -3.0 dB/octave Random 5-20 Hz at 1 m2/Sec3 Random 20-200 Hz at -3 m/Sec2
Shock	Half-sine, 5g/11ms	Half-sine, 15g/11ms
Free Fall	100 mm/3 axis	1,200 mm/all edges and corners (packaged)

2.2 Power Requirements

The XMCspan uses only +5.0V from the VMEbus backplane. On-board power supplies generate the required voltages for the various ICs. The XMCspan connects the +12V and -12V supplies from the backplane to the PMC sites while the +3.3V power supplied to the PMC sites comes from the +5.0V backplane power. A maximum of 15A of +3.3V power is available to the PMC sites, however the 90W +5.0V limit must be observed as well as any cooling limitations.

The following table provides an estimate of the typical and maximum power required.

Table 2-2 Power Requirements

Board Variant	Measured Power	Notes
XMCspan	7.5W	1.5A at 5V
XMCspan with 2x MEN P601	13W	2.6A at 5V

Table 2-2 Power Requirements (continued)

Board Variant	Measured Power	Notes
XMCspan with 2x PMC Test Adapter	38W	7.6A at 5V
XMCspan with 2x PrPMC-280S	39.5W	7.9A at 5V

The following table shows the power available when the XMCspan is installed in either a 3-row or 5-row chassis and when PMCs are present.

1 Keep below power limit. Cooling limitations must be considered.

2.2.1 Backplane Power Requirements

The following table lists the backplane power requirements.

Table 2-3 Backplane Power Requirements

Voltage	Maximum Current	Available Power
+5V	9 pins at 2A	90W
+12V	1 pin at 2A	24W
-12V	1 pin at 2A	24W

2.3 Checking the Box Contents

NOTICE

Static discharge can damage circuits.

Avoid touching areas of integrated circuitry or take antistatic precautions (ESD wrist strap or shoes).

1. Make sure that you have received the following items: printed Getting Started manual or Quick Start guide, XMCspan board, any optional items ordered.
2. Check the items for damages, and report any damage or difference to customer service.
3. If applicable, remove the desiccant bag that shipped together with the board, and dispose of it according to your country's legislation.

2.4 Installing a Mezzanine Card

The XMCspan supports the following mezzanine cards: XMC, PMC, and PrPMC. These mezzanine cards mount on the XMCspan. Install the mezzanine cards on the XMCspan before installing the XMCspan on the VME base board.

For more information on installing a supported mezzanine card, see the installation instructions that came with it.

NOTICE

Inserting or removing modules with power applied may result in damage to module components. Avoid touching areas of integrated circuitry as static discharge can damage these circuits.

NOTE: This procedure assumes that you have read the Installation and Use manual of the VME base board, and that you have properly configured the board according to the information found in the manual. For more information about the manual, see [Appendix A, Related Documentation](#).

To install any one of the supported mezzanine cards on your XMCspan, do the following:

1. Attach an ESD strap to your wrist.
2. Attach the other end of the ESD strap to an electrical ground.
The ESD strap must be secured to your wrist and to ground throughout this procedure.
3. If the XMCspan is already mounted on your VME base board, do the following:
 - Perform an operating system shutdown.
 - Turn off the AC or DC power and remove the AC cord or DC power lines from the system.
 - Remove chassis or system cover(s) as necessary for access to the VME base board.
 - If the VME base board has already been installed in a VMEbus card slot, carefully remove it and place it with connectors P1 and P2 facing you.
4. Position the XMCspan with the P1 and P2 connectors facing you.

- Remove the slot filler panel from the XMCspan front panel.

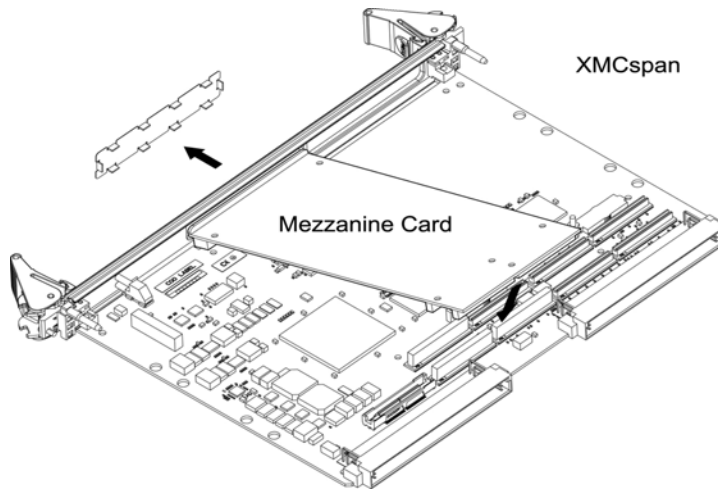

- Slide the module port connector into the slot opening on the XMCspan front panel.
- Align the module over the XMCspan.
- Align the connectors on the underside of the module with the corresponding connectors on the XMCspan.

Mezzanine Card Slot	Connectors
Mezzanine Card Slot 1	When installing a PMC/PrPMC module, use the following connectors: J11, J12, J13, and J14. When installing an XMC module, use J15.
Mezzanine Card Slot 2	When installing a PMC/PrPMC module, use the following connectors: J21, J22, J23, and J24. When installing an XMC module, use J25.

- Align the keying hole on the module with the keying pin on the XMCspan.
- Gently press the module onto the XMCspan.
- Turn the XMCspan component-side down.
- Insert the four short Phillips screws supplied with the XMCspan through the holes on the underside of the module, into the standoffs at the corners of the base board, and then tighten the screws.

NOTE: Some PMCs use a screw at each corner; others require only two screws at the forward corners.

2.5 Installing the Primary XMCspan

The XMCspan mounts on the VME base board. To upgrade or install an XMCspan, refer to the figure shown below and proceed as follows.

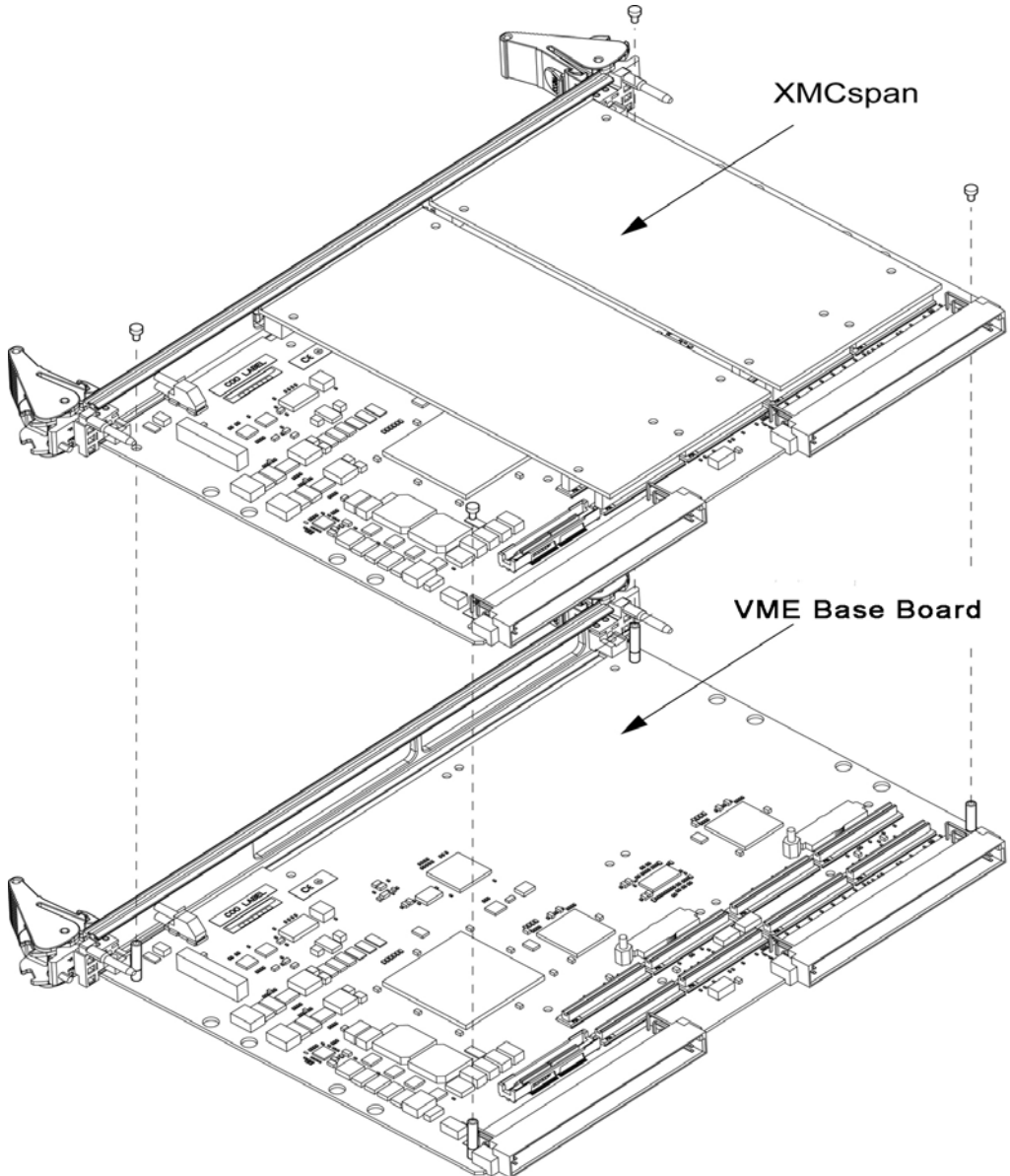

This procedure assumes that you have read the *Installation and Use* manual of the VME base board, and that you have properly configured the board according to the information found in the manual. For more information about the manual, see [Appendix A, Related Documentation, on page 47](#).



Dangerous voltages, capable of causing death, are present in this equipment. Use extreme caution when handling, testing, and adjusting.

NOTICE

Inserting or removing modules with power applied may result in damage to module components. Avoid touching areas of integrated circuitry as static discharge can damage these circuits.

1. Attach an ESD strap to your wrist.
2. Attach the other end of the ESD strap to an electrical ground.
The ESD strap must be secured to your wrist and to ground throughout this procedure.
Note: The system chassis may not be grounded if it is unplugged.
3. Perform an operating system shutdown.
4. Turn off the AC or DC power and remove the AC cord or DC power lines from the system.
5. Remove chassis or system cover(s) as necessary for access to the VME base board.
6. If the VME base board has already been installed in a VMEbus card slot, carefully remove it and place it with connectors P1 and P2 facing you.
7. Attach the four standoffs to the VME base board. For each standoff:
 - Insert the threaded end into the standoff hole at each corner of the VME base board.
 - Thread the locking nuts into the standoff tips and tighten.
8. Place the XMCspan on top of the VME base board.
9. Align the mounting holes in each corner to the standoffs and align XMCspan connector P3 with VME connector J6.
10. Gently press the XMCspan and VME base board together, and then verify that the connectors are fully seated.
11. Insert four short screws (Phillips type) through the holes at the corners of the XMCspan and into the standoffs on the VME base board.
12. Tighten the screws securely.

2.6 Installing the Secondary XMCspan

The secondary XMCspan mounts on top of a primary XMCspan module. To install on your VME base board, do the following steps while referring to the figure shown below..

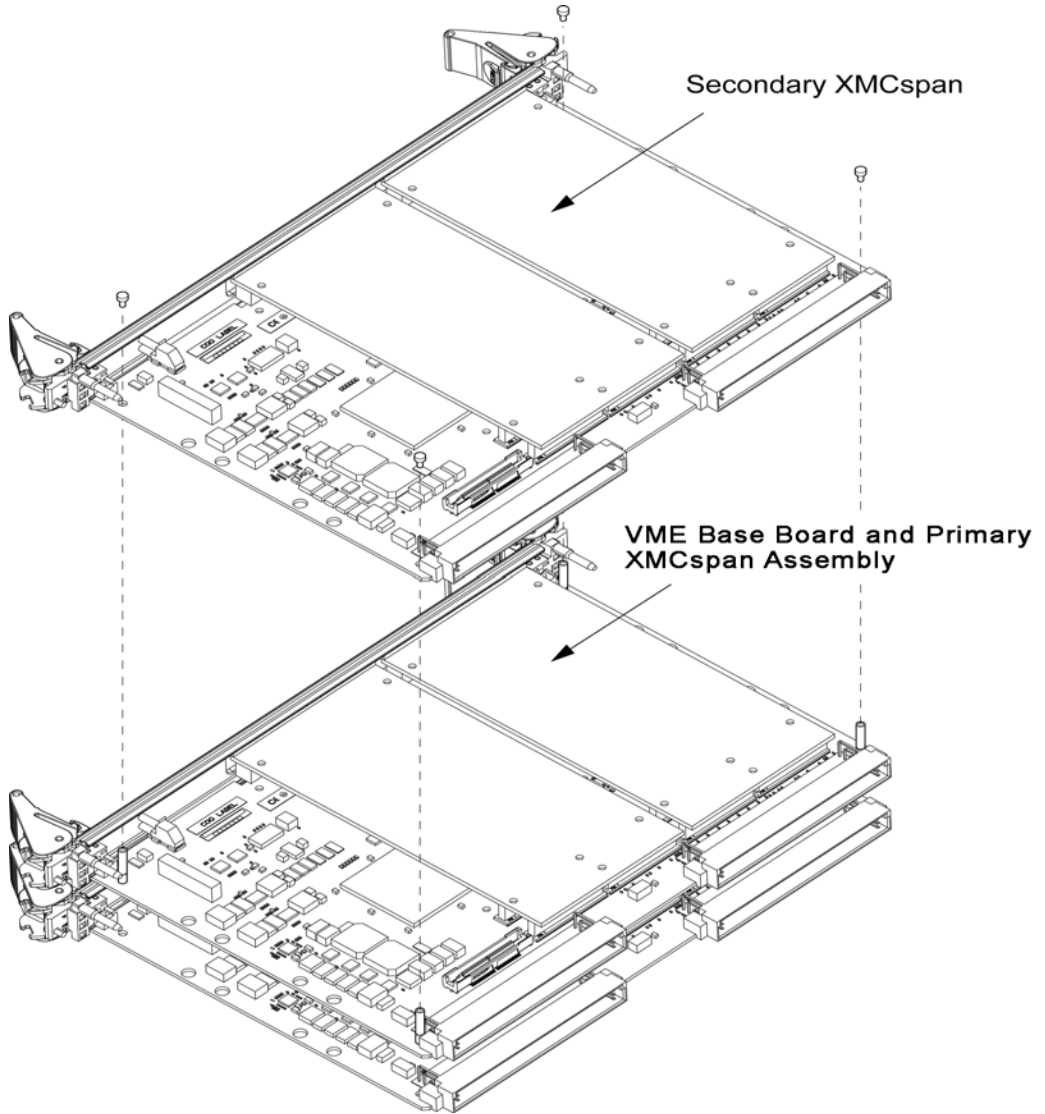



Dangerous voltages, capable of causing death, are present in this equipment. Use extreme caution when handling, testing, and adjusting.

NOTICE

Inserting or removing modules with power applied may result in damage to module components. Avoid touching areas of integrated circuitry as static discharge can damage these circuits.

1. Attach an ESD strap to your wrist.
2. Attach the other end of the ESD strap to an electrical ground.
The ESD strap must be secured to your wrist and to ground throughout this procedure.
Note: The system chassis may not be grounded if it is unplugged.
3. Perform an operating system shutdown.
4. Turn off the AC or DC power and remove the AC cord or DC power lines from the system.
5. Remove chassis or system cover(s) as necessary for access to the VME base board.
6. If the primary XMCspan and VME base board is already installed in the VME chassis, carefully remove it and place it with connectors P1 and P2 facing you.
7. Remove four screws (Phillips type) from the standoffs in each corner of the primary XMCspan.
8. Attach the four standoffs from the secondary XMCspan mounting kit to the primary XMCspan by screwing the threaded male portion of the standoffs in each corner of the primary XMCspan.
9. Place the secondary XMCspan on top of the primary XMCspan.
10. Align the mounting holes in each corner to the standoffs, and then align the secondary XMCspan connector P3 with primary XMCspan connector J3.
11. Gently press the two XMCspan modules together and verify that P3 is fully seated in J3.
12. Insert the four screws (Phillips type) through the holes at the corners of the secondary XMCspan, and into the standoffs on the primary XMCspan.
13. Tighten the screws securely.
Note: The screws have two different head diameters. Use the screws with the smaller heads on the standoffs next to the VMEbus connectors P1 and P2.

2.7 Removing the XMCspan

This procedure is applicable to the primary and secondary XMCspan.



Dangerous voltages, capable of causing death, are present in this equipment. Use extreme caution when handling, testing, and adjusting.

NOTICE

Inserting or removing modules with power applied may result in damage to module components. Avoid touching areas of integrated circuitry as static discharge can damage these circuits.

1. Attach an ESD strap to your wrist.
2. Attach the other end of the ESD strap to an electrical ground.
The ESD strap must be secured to your wrist and to ground throughout this procedure.
Note: The system chassis may not be grounded if it is unplugged.
3. Perform an operating system shutdown.
4. Turn off the AC or DC power and remove the AC cord or DC power lines from the system.
5. Remove chassis or system cover(s) as necessary for access to the VME base board.
6. If the VME base board has already been installed in a VMEbus card slot, carefully remove it.
7. Remove the four screws (Phillips type) from each corner of the XMCspan.
8. Gently remove the XMCspan, and then remove the standoffs from the VME base board.

Resetting the XMCspan

3.1 Reset Sources

There are many ways to reset the XMCspan. The following sources will generate a board level hardware reset for the whole XMCspan, including the PEX8533 and other devices connected to one of the PCI/PCI-X buses:

- Power-up reset
This reset occurs when the XMCspan is powered on.
- VME hardware reset
The VME base board has a single push button switch that provides abort and reset functions. When the switch is pressed for more than 3 seconds, a board-level hardware reset is generated.
- VMEbus reset
When the VME base board receives a VMEbus reset, it combines this signal with any local reset signal. This resets all devices on the base board, including the XMCspan.

Reset Switch

The standard reset/abort switch has been omitted on the XMCspan.

Reset Controller

The on-board CPLD is used to handle power-up and reset. The LC4128V-27TN100C from Lattice, which is a 100-pin TSSOP package, is used.

Resetting the XMCspan

Controls, LEDs, and Connectors

4.1 Overview

This chapter summarizes the LEDs and connectors used in the XMCspan.

4.2 Board Layout

The following figures shows the components, LEDs, and connectors on the XMCspan.

Figure 4-1 Board Layout

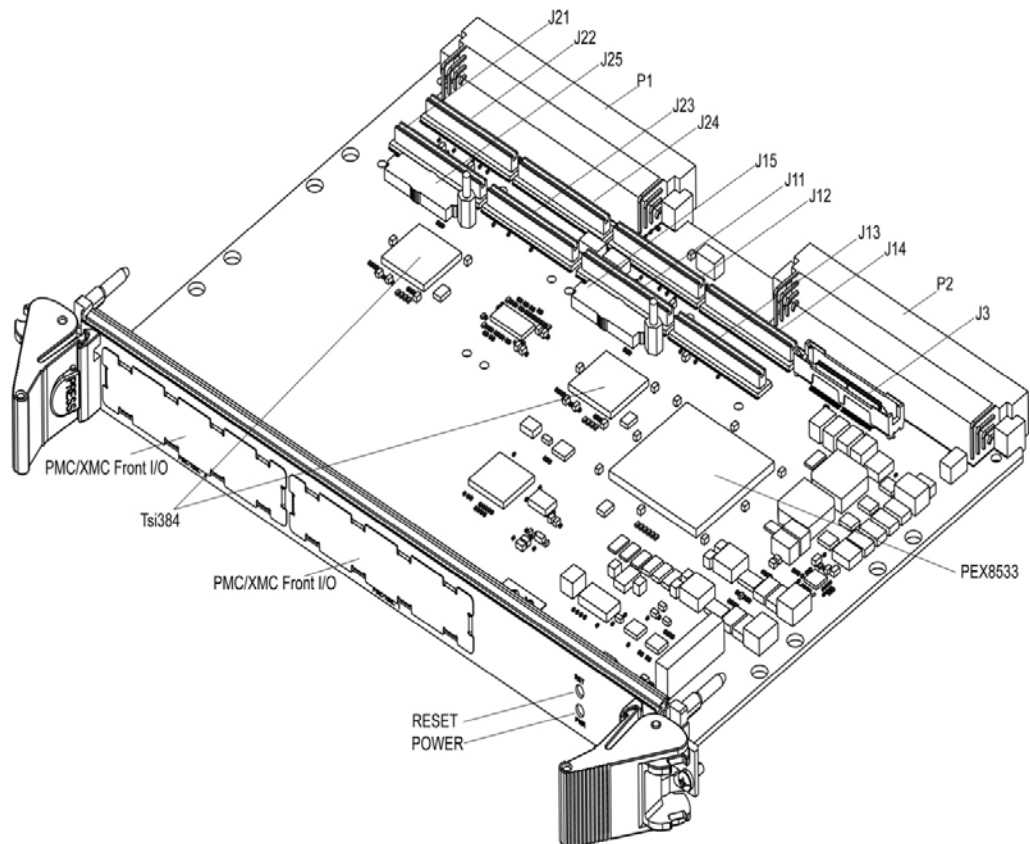

4.3 Face Plate

The following shows the face plate and the two variants of the handles for the XMCspan.

Figure 4-2 XMCspan with SCANBE Handles

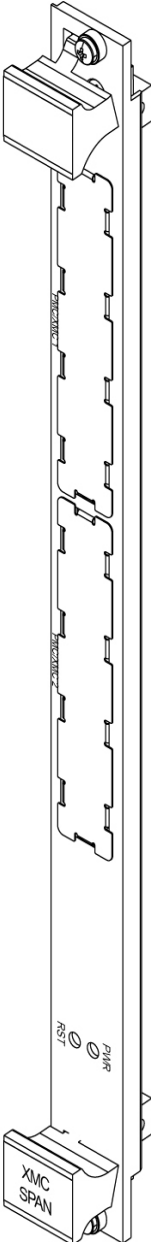
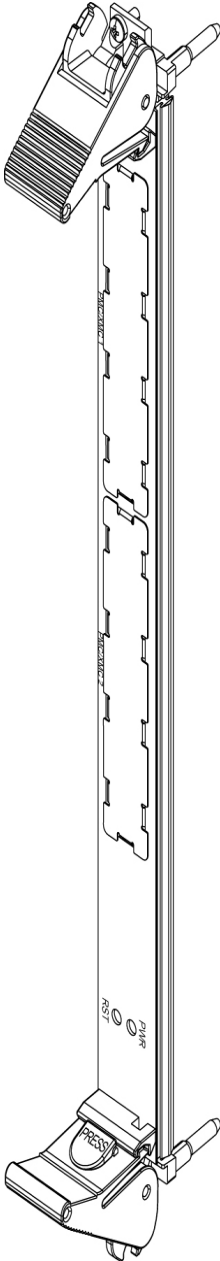

Figure 4-3 XMCspan with IEEE Handles



4.4 Connectors

The XMCspan module connectors provide I/O and interfaces to the MVME7100 processor modules and to other XMCspan modules. The pin assignments for the XMCspan connectors are detailed in the succeeding sections.

Table 4-1 Connector Pin-outs

Location	Function
P1	5-row VME connector
P2	5-row VME connector
J11 to J14, J21 to J24	PMC sites
J15, J25	XMC sites
P3	Connection to MVME7100 PCI Express expansion connector located on the bottom side of the board
J3	Connection to secondary XMCspan PCI Express expansion connector located on the top side of the board

4.4.1 VME Connectors

The VMEbus connector P1 is used for the XMCspan power supply. There is no connection to the VMEbus except for signal SYSRESET#, which is connected to the on-board CPLD. The P1 connector also connects the following daisy chains:

- IACKIN* and IACKOUT* with BG0IN* and BG0OUT*
- BG1IN* and BG1OUT* and BG2IN* and BG2OUT* with BG3IN* and BG3OUT*

The VMEbus connector P2 is used for power supply and user I/O connection to the rear transition module. There is no connection to the VME bus.

Table 4-2 Pin definition for VME connector P2

Pin	Row Z	Row A	Row B	Row C	Ro
1	PMC2IO_2	PMC1IO_2	+5V	PMC1IO_1	PMC2IO_1
2	GND	PMC1IO_4	GND	PMC1IO_3	PMC2IO_3
3	PMC2IO_5	PMC1IO_6	-	PMC1IO_4	PMC2IO_4
4	GND	PMC1IO_8	-	PMC1IO_7	PMC2IO_6

Controls, LEDs, and Connectors

Table 4-2 Pin definition for VME connector P2 (continued)

Pin	Row Z	Row A	Row B	Row C	Ro
5	PMC2IO_8	PMC1IO_10	-	PMC1IO_9	PMC2IO_7
6	GND	PMC1IO_12	-	PMC1IO_11	PMC2IO_9
7	PMC2IO_11	PMC1IO_14	-	PMC1IO_13	PMC2IO_10
8	GND	PMC1IO_16	-	PMC1IO_15	PMC2IO_12
9	PMC2IO_14	PMC1IO_18	-	PMC1IO_17	PMC2IO_13
10	GND	PMC1IO_20	-	PMC1IO_29	PMC2IO_15
11	PMC2IO_17	PMC1IO_22	-	PMC1IO_21	PMC2IO_16
12	GND	PMC1IO_24	GND	PMC1IO_23	PMC2IO_18
13	PMC2IO_20	PMC1IO_26	+5V	PMC1IO_25	PMC2IO_19
14	GND	PMC1IO_28	-	PMC1IO_27	PMC2IO_21
15	PMC2IO_23	PMC1IO_30	-	PMC1IO_29	PMC2IO_22
16	GND	PMC1IO_32	-	PMC1IO_31	PMC2IO_24
17	PMC2IO_26	PMC1IO_34	-	PMC1IO_33	PMC2IO_25
18	GND	PMC1IO_36	-	PMC1IO_35	PMC2IO_27
19	PMC2IO_29	PMC1IO_38	-	PMC1IO_37	PMC2IO_28
20	GND	PMC1IO_40	-	PMC1IO_39	PMC2IO_30
21	PMC2IO_32	PMC1IO_42	-	PMC1IO_41	PMC2IO_31
22	GND	PMC1IO_44	GND	PMC1IO_43	PMC2IO_33
23	PMC2IO_35	PMC1IO_46	-	PMC1IO_45	PMC2IO_34
24	GND	PMC1IO_48	-	PMC1IO_47	PMC2IO_36
25	PMC2IO_38	PMC1IO_50	-	PMC1IO_49	PMC2IO_37
26	GND	PMC1IO_52	-	PMC1IO_51	PMC2IO_39
27	PMC2IO_41	PMC1IO_54	-	PMC1IO_53	PMC2IO_40

Controls, LEDs, and Connectors

Table 4-2 Pin definition for VME connector P2 (continued)

Pin	Row Z	Row A	Row B	Row C	Ro
28	GND	PMC1IO_56	-	PMC1IO_55	PMC2IO_42
29	PMC2IO_44	PMC1IO_58	-	PMC1IO_57	PMC2IO_43
30	GND	PMC1IO_60	-	PMC1IO_59	PMC2IO_45
31	PMC2IO_46	PMC1IO_62	GND	PMC1IO_61	GND
32	GND	PMC1IO_64	+5V	PMC1IO_63	VPC

4.4.2 LED Information

The XMCSPAN has two front panel LEDs: PWR and RESET. The PWR LED is illuminated red if the on-board supplies are not functioning properly. The PWR LED is off when the supplies are good. The RESET LED is illuminated yellow if the board is in reset. The RESET LED is illuminated green when not in reset. The XMCSPAN-001 has LEDs that are mounted on the surface of the PWB and not visible from the front panel. The function of these LEDs is described in the tables below.

Table 4-3 PEX 8533 PCIE Switch

LED	Description	Color
D10	PEX_PORT_GOOD_0	Amber
D9	PEX_PORT_GOOD_1 (For more details, refer to Table 4-4 on page 43).	Amber
D8	PEX_PORT_GOOD_2	Amber
D7	PEX_PORT_GOOD_8	Amber
D6	PEX_PORT_GOOD_8 (For more details, refer to Table 4-4 on page 43).	Amber
D5	PEX_PORT_GOOD_10	Amber

PEX 8533 PCIE switch indicates if there is a port link or not. If it is On, then the link is good, and if it is Off then there is no link. D5 will only be on, when XMC 1 is installed. D6 will only be on, when XMC 2 is installed. D7 will only be on, when an additional XMCSPAN is installed.

Table 4-4 Tsi384 PCIE-PCIX PMC2

LED	Description	Color
D20	PEX_LANE_3	Amber
D21	PEX_LANE_2	Amber
D22	PEX_LANE_1	Amber
D23	PEX_LANE_0	Amber

Tsi384 PCIE-PCIX PMC2 On indicates that the PCIE lane is good.

Functional Description

5.1 Overview

This chapter describes the physical structure of the XMCspan. It shows the detailed block diagram of the XMCspan and its primary interfaces.

5.2 Block Diagram

The following figure gives an overview of the main function blocks of the XMCspan and how they are interconnected.

Figure 5-1 XMCspan Block Diagram

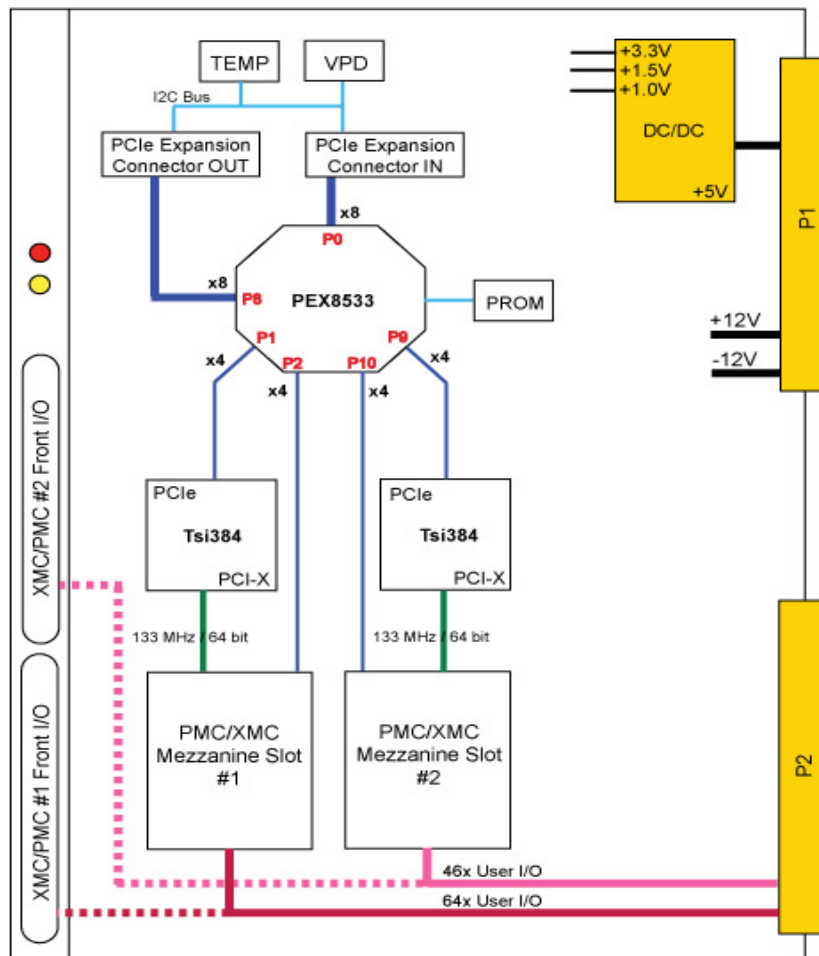

5.3 PEX8533 PCI Express Switch

The XMCspan provides an eight-lane (x8) PCI Express interface that expands the VME bus board. This PCI Express interface is available at connector J3, and connected to the uplink port Port 0 of the PCI Express Switch PEX8533. The PEX8533 gives PCI Express switching capability that conforms to the latest revision of the PCI Express Base specification.

5.4 PEX8533 Station and Port Configuration

The 32 PCI Express lanes are implemented equally across two stations, and are connected by the internal switch fabric to the central RAM. Each station supports up to 16 SerDes modules that are integrated on the chip, and provide the 32 PCI Express hardware interface lanes. The lanes can be combined to create one to three ports per station. Each port implements the PCI Express Base R1.1 physical, data link, and transaction layer.

5.5 XMCspan Stacking

The XMCspan provides a second eight-lane (x8) PCI Express interface to allow a second XMCspan module to be stacked on top of the VME base board. This interface is available at PCI Express expansion output connector J4, and connected to the downlink port Port 8 of PEX8533.

5.6 Mezzanine Card Sites

The XMCspan has two mezzanine card sites that support XMC, PMC, and PrPMC modules. PMC-mode, XMC-mode, or dual-mode mezzanine cards are also supported.

The mezzanine cards are compliant with:

- IEEE 1386-2001
- IEEE 1386.1-2001
- ANSI/VITA 32-2003
- ANSI/VITA 35-2000
- ANSI/VITA 39-2003
- ANSI/VITA 42.0-2005
- ANSI/VITA 42.3-2006

5.7 Mezzanine Card Identification

The mezzanine cards can be identified by reading the VPD serial EEPROM. The connector signals MSCL and MSCA are connected to the I2C bus.

5.8 XMC.3 Support

The XMCspan implements only the primary XMC.3 connector receptacles at locations J15 and J25. Each primary connector uses 16 differential pairs: 8 defined as transmit, and 8 defined as receive, plus one 100 MHz differential pair for the PCI Express clock reference. A single four-lane PCI Express interface is connected between each connector and the PEX8533 PCI Express Switch.

- PEX8533 Port 2 is connected to connector J15.
- PEX8533 Port 10 is connected to connector J25.

The XMC and XMC.3 specification use sideband signals to power, reset, identify, and manage the XMC card.

5.9 PMC AND PRPMC Support

Each of the two mezzanine card sites has a separate PCI Express-to-PCI/PCI-X Bridge, which is the Tsi384.

The PCI signaling voltage for the PMC is 3.3 V.

Each of the two mezzanine card sites implements three PMC connectors for 64-bit wide PCI/PCI-X interface at locations Jn1, Jn2, and Jn3. Each site also implements one PMC connector for user I/O signals. Both sites support front panel access to the PMC card, and rear panel access to PMC user I/O via connector Jn4. The PMC sites support 32/64 bit data. In PCI mode, 33 and 66 MHz clocks are supported. In PCIX mode, 66, 100 and 133 MHz clocks are supported. SW1-6 must be on to enable 133 MHz PCI-X. If it's off, the maximum speed is 100 MHz PCI-X. The PMC connectors have the standard PCI/PCI-X configuration signals. When a module is installed, the Tsi384 configures the clock and mode to the modules capabilities.

5.10 PCI Buses

The XMCspan has various PCI buses. There is one virtual PCI bus in the PEX8533 PCI Express switch, and two physical PCI/PCI-X buses between the module sites and the Tsi384 bridge.

5.11 TSI384 PCI EXPRESS-TO-PCI/PCI-X Bridge

The Tsi384 is a bridge that allows the migration of legacy PCI and PCI-X bus interfaces to the new, advanced serial PCI Express interface.

Tsi384 is equipped with a standard but flexible PCI Express port that scales to x1, x2, or x4 lanes with a maximum of 1 GB per second of throughput per transmit and receive direction. Its PCI-X interface can operate up to 133 MHz in PCI-X mode, or up to 66 MHz in PCI mode.

On the XMCspan, the Tsi384 is a 4-lane PCI Express interface that is configured in forward transparent bridge mode, and is connected with the PEX8533 PCI Express Switch.

PEX8533 Port 1 is connected with Tsi384 Bridge for module site 1.

PEX8533 Port 9 is connected with Tsi384 Bridge for module site 2.

5.12 Serial EEPROM For VPD

The XMCspan has an 8 KB dual address serial EEPROM. The EEPROM contains vital product data (VPD) configuration information, which may include the following information, among others:

- Manufacturer
- Board Revision
- Build Version
- Date of Assembly

Table 5-1 I2C Bus Address Map

Bus	Address	Size	Function
0	E0x	NA	I2C Bus Multiplexer on the first XMCspan module
0	E2x	NA	I2C Bus Multiplexer on the first XMCspan module
1	90x	NA	Temperature Sensor LM75
1	ACx	8 KB	VPD serial EEPROM
2	ACx	-	VPD of XMC module 1
2	AEx	-	VPD of XMC module 2

5.13 Clocking Scheme

A 100MHz PCI Express reference clock is provided to the XMCspan through expansion connector pins J3.27 and J3.29. The reference clock is used to generate all other PCI Express clocks using an ICS9DB108, which is IDT's 8-output differential buffer for PCI Express.

The PCI/PCI-X bus clocks are generated by the Tsi384 internal clock generator. The clock generator uses REFCLK positive and negative inputs to generate the clock on PCI_CLK0 outputs. The clock frequency is determined by PCI_PCIXCAP, PCI_M66EN, and PCI_SEL100.

The table below lists all the clocks required by the XMCspan, along with their frequency, source, and clock target device.

Table 5-2 Clocking Scheme

Clock Signal	Clock Source	Frequency	Device
CLK_PCI1	Tsi384_1	-	PMC Site 1
CLK_PCI2	Tsi384_2	-	PMC Site 2
CLK_PCIE0	ICS9DB108	100 MHz	PEX8533
CLK_PCIE1	ICS9DB108	100 MHz	Tsi384 Bridge 1
CLK_PCIE2	ICS9DB108	100 MHz	XMC Site 1
CLK_PCIE8	ICS9DB108	100 MHz	XMCspan connector J4
CLK_PCIE9	ICS9DB108	100 MHz	Tsi384 Bridge 2
CLK_PCIE10	ICS9DB108	100 MHz	XMC Site 2

5.14 Debugging Support

The XMCspan has an 8-position DIP switch that is mainly used for factory testing and debugging.

The following table describes the function of each position on the switch.

Table 5-3 Debugging Support

Position	Default	Function
SW1-1	OFF	Factory use only

Functional Description

Table 5-3 *Debugging Support (continued)*

Position	Default	Function
SW1-2	OFF	Factory use only
SW1-3	OFF	Factory use only
SW1-4	OFF	Factory use only
SW1-5	OFF	Factory use only
SW1-6	OFF	This is used to enable 133 MHz PCI-X mode for the PMC slots.
SW1-7	OFF	Factory use only
SW1-8	OFF	Factory use only

Related Documentation

A.1 Penguin Solutions Documentation

Technical documentation can be found by using the Documentation Search at <https://www.penguinsolutions.com/edge/support/> or you can obtain electronic copies of documentation by contacting your local sales representative.

Table A-1 Penguin Edge Documentation

Document Title	Document Number
XMCspan Data Sheet	XMCspan-DS
MVME4100 Data Sheet	MVME4100-DS
MVME7100 Data Sheet	MVME7100-DS
MVME7100 Installation and Use	6806800E08
MVME4100 Installation and Use	6806800H18

A.2 Manufacturers' Documents

For additional information, refer to the following table for manufacturers' data sheets or user's manuals. As additional help, a source for the listed document is provided. Please note that, while these sources have been verified, the information is subject to change without notice.

Table A-2 Manufacturers' Documentation

Document Title	Publication Number
ATML SPI Serial EEPROMs 128K (16,384 x 8) 256K (32,768 x 8)	3368J-SEEPR-06/07
Lattice Semiconductor Corporation ispMACH™ 4000V/B/C/Z Family 3.3V/2.5V/1.8V In-System Programmable SuperFAST™ High Density PLDs	Data Sheet DS1020 June 2007
PLX Technology ExpressLane PEX 8533-AA 32-Lane/6-Port PCI Express Gen 1 Switch Data Book	Version 1.6 January 2008
Tundra Semiconductor Corporation Tsi384 PCIe-to-PCI/X Bridge User Manual	80B2000_MA001_03 December 2006

A.3 Related Specifications

For additional information, refer to the following table for related specifications.

Table A-3 Related Specifications

Organization	Document Title
IEEE	IEEE Standard for a Common Mezzanine Card (CMC) Family, IEEE 1386-2001
	IEEE Standard Physical and Environmental Layers for PCI Mezzanine Cards (PMC), IEEE 1386.1-2001
VITA	PCI Express Base Specification, PCI SIG Revision 2.0
	PCI-X Addendum to the PCI Local Bus Specification, PCI SIG Revision 1.0a
	PCI-X Auxiliary Standard for PMCs and Processor PMCs, ANSI/VITA 39-2003
	Processor PMC, VITA 32-2003
	PMC-P4 Pin Out Mapping to VME-P0 and VME64x-P2, VITA 35-2000
	VME64, ANSI/VITA 1-1994
	VME64 Extension, ANSI/VITA 1.1-1997
	XMC Switched Mezzanine Card, VITA 42.0-2005, Draft 0.29
	XMC PCI Express Protocol Layer Standard, VITA 42.3-2006



Penguin Solutions is a trade name used by SMART Embedded Computing, Inc., a wholly owned subsidiary of SMART Global Holdings, Inc. Penguin Edge is a trademark owned by Penguin Computing, Inc., a wholly owned subsidiary of SMART Global Holdings, Inc. NXP and QorIQ are trademarks of NXP B.V. All other logos, trade names, and trademarks are the property of their respective owners. ©2022 SMART Embedded Computing, Inc.