MVME721X RTM

Installation and Use

P/N: 6806800M42E

September 2019



© 2019 SMART Embedded Computing™, Inc.

All Rights Reserved.

Trademarks

The stylized "S" and "SMART" is a registered trademark of SMART Modular Technologies, Inc. and "SMART Embedded Computing" and the SMART Embedded Computing logo are trademarks of SMART Modular Technologies, Inc. All other names and logos referred to are trade names, trademarks, or registered trademarks of their respective owners. These materials are provided by SMART Embedded Computing as a service to its customers and may be used for informational purposes only.

Disclaimer*

SMART Embedded Computing (SMART EC) assumes no responsibility for errors or omissions in these materials. **These materials are provided "AS IS" without warranty of any kind, either expressed or implied, including but not limited to, the implied warranties of merchantability, fitness for a particular purpose, or non-infringement.** SMART EC further does not warrant the accuracy or completeness of the information, text, graphics, links or other items contained within these materials. SMART EC shall not be liable for any special, indirect, incidental, or consequential damages, including without limitation, lost revenues or lost profits, which may result from the use of these materials. SMART EC may make changes to these materials, or to the products described therein, at any time without notice. SMART EC makes no commitment to update the information contained within these materials.

Electronic versions of this material may be read online, downloaded for personal use, or referenced in another document as a URL to a SMART EC website. The text itself may not be published commercially in print or electronic form, edited, translated, or otherwise altered without the permission of SMART EC.

It is possible that this publication may contain reference to or information about SMART EC products, programming, or services that are not available in your country. Such references or information must not be construed to mean that SMART EC intends to announce such SMART EC products, programming, or services in your country.

Limited and Restricted Rights Legend

If the documentation contained herein is supplied, directly or indirectly, to the U.S. Government, the following notice shall apply unless otherwise agreed to in writing by SMART Embedded Computing.

Use, duplication, or disclosure by the Government is subject to restrictions as set forth in subparagraph (b)(3) of the Rights in Technical Data clause at DFARS 252.227-7013 (Nov. 1995) and of the Rights in Noncommercial Computer Software and Documentation clause at DFARS 252.227-7014 (Jun. 1995).

SMART Embedded Computing, Inc.

2900 S. Diablo Way, Suite 190

Tempe, Arizona 85282

USA

*For full legal terms and conditions, visit www.smartembedded.com/ec/legal

Table of Contents

- About this Manual 7

- Safety Notes 11

- Sicherheitshinweise 15

- 1 Introduction 19**
 - 1.1 Features 19
 - 1.2 Rear Transition Module Layout 20
 - 1.3 Standard Compliances 21
 - 1.4 Mechanical Data 21
 - 1.5 Ordering Information 22

- 2 Hardware Preparation and Installation 23**
 - 2.1 Introduction 23
 - 2.2 Unpacking and Inspecting the RTM 23
 - 2.3 Requirements 24
 - 2.3.1 Environmental Requirements 24
 - 2.4 RTM Installation and Removal 25
 - 2.4.1 PMC I/O Module (PIM) Installation 25
 - 2.4.2 Installing the RTM 27
 - 2.4.3 Removing the RTM 32

- 3 Controls, LEDs, and Connectors 33**
 - 3.1 Overview 33
 - 3.2 EEPROM Address Switch, S1 33
 - 3.3 Rear Panel Connectors and LEDs 34
 - 3.3.1 Rear Panel Connectors 35
 - 3.3.1.1 J1 (Serial) and J2 (Ethernet) Pinout Connectors 35
 - 3.3.1.2 PMC Input/Output Module (PIM) Connectors (J10/J14) 37
 - 3.3.1.3 VME Backplane P2 Connector 40
 - 3.3.2 LEDs 42
 - 3.4 FRU Serial EEPROM 42

Table of Contents

A	Related Documentation	43
A.1	SMART Embedded Computing Documentation	43

List of Figures

Figure 1-1	Component Layout	20
Figure 2-1	Installing the PIM	26
Figure 2-2	IEEE Handles	27
Figure 2-3	IEEE Handles	28
Figure 2-4	IEEE Handles	29
Figure 2-5	IEEE Handles	30
Figure 2-6	Scanbe Handles	31
Figure 3-1	S1 Switch Positions	33
Figure 3-2	Rear Panel Connectors and LEDs	34

List of Figures

List of Tables

Table 1-1	Standard Compliances	21
Table 1-2	Mechanical Data	21
Table 2-1	Environmental Conditions	24
Table 3-1	SEEPROM Address Switch Assignments (RTM)	33
Table 3-2	Switch Settings and Device Addresses	33
Table 3-3	Transition Module Connectors	35
Table 3-4	J1 and J2 Connector Pin Assignments	35
Table 3-5	J10 Connector Pin Assignments	37
Table 3-6	J14 Connector Pin Assignments	38
Table 3-7	VME Backplane P2 Connector Pin Assignments	40
Table 3-8	Front Panel LEDs	42
Table A-1	SMART EC Documents	43

List of Tables

About this Manual

Overview of Contents

This manual is intended for users who install and configure MVME721X RTM. It is assumed that the user is familiar with the standard cabling procedures, installation and removal procedures of MVME721X RTM. The user must be a professional engineer in the server device field, who has been trained and is able to identify danger levels when operating the device.

This manual is divided into the following chapters and appendices.

Chapter 1, Introduction describes the main features of the RTM.

Chapter 2, Hardware Preparation and Installation details the installation prerequisites and the installation itself.

Chapter 3, Controls, LEDs, and Connectors describes external interfaces such as connectors and LEDs.

Appendix A, Related Documentation lists further SMART EC documents for other products that use the RTM, such as MVME7100, MVME2500, iVME7210, and MVME4100.

Abbreviations

This document uses the following abbreviations:







Abbreviation	Definition
CPLD	Complex Programmable Logic Device
DDR3	Double Data Rate 3
DMI	Direct Media Interface
DUART	Dual UART
EEPROM	Erasable Programmable Read-Only Memory
FCC	Federal Communications Commission
IEEE	Institute of Electrical and Electronics Engineers
MCP	Multi-Chip Package
MRAM	Magnetoresistive Random Access Memory
PCI	Peripheral Component Interconnect
PCI-E	PCI Express

Abbreviation	Definition
PIM	PCI Mezzanine Card Input/Output Module
PLD	Programmable Logic Device
PMC	PCI Mezzanine Card (IEEE P1386.1)
RTC	Real-Time Clock
RTM	Rear Transition Module
SATA	Serial AT Attachment
UART	Universal Asynchronous Receiver-Transmitter
VITA	VMEbus International Trade Association
VME	Versa Module Eurocard
XMC	PCI Express Mezzanine Card

Conventions

The following table describes the conventions used throughout this manual.

Notation	Description
0x00000000	Typical notation for hexadecimal numbers (digits are 0 through F), for example used for addresses and offsets
0b0000	Same for binary numbers (digits are 0 and 1)
bold	Used to emphasize a word
Screen	Used for on-screen output and code related elements or commands. Sample of Programming used in a table (9pt)
Courier + Bold	Used to characterize user input and to separate it from system output
<i>Reference</i>	Used for references and for table and figure descriptions
File > Exit	Notation for selecting a submenu
<text>	Notation for variables and keys
[text]	Notation for software buttons to click on the screen and parameter description
...	Repeated item for example node 1, node 2, ..., node 12

Notation	Description
.	Omission of information from example/command that is not necessary at the time
..	Ranges, for example: 0..4 means one of the integers 0,1,2,3, and 4 (used in registers)
	Logical OR
	Indicates a hazardous situation which, if not avoided, could result in death or serious injury
	Indicates a hazardous situation which, if not avoided, may result in minor or moderate injury
	Indicates a property damage message
	Indicates a hot surface that could result in moderate or serious injury
	Indicates an electrical situation that could result in moderate injury or death
<p data-bbox="272 1286 386 1338">Use ESD protection</p> 	Indicates that when working in an ESD environment care should be taken to use proper ESD practices
	No danger encountered, pay attention to important information

Summary of Changes

This manual has been revised and replaces all prior editions.

Part Number	Publication Date	Description
6806800M42E	September 2019	SMART Embedded Computing re-branding
6806800M42D	April 2015	Re-branded to Artesyn template.
6806800M42C	July 2011	Added Removing the RTM on page 32 . Updated drawings of IEEE and Scanbe handles and updated RTM installation and removal procedures in RTM Installation and Removal on page 25 . Updated information on Table 2-1 on page 24 .
6806800M42B	June 2011	Added tables and information on pin assignments for J1 (Serial) and J2 (Ethernet) Pinout Connectors, PMC Input/Output Module (PIM) Connectors (J10/J14), and VME Backplane P2 Connector under Rear Panel Connectors on page 35 .
6806800M42A	May 2011	GA Version

Safety Notes

This section provides warnings that precede potentially dangerous procedures throughout this manual. Instructions contained in the warnings must be followed during all phases of operation, service, and repair of this equipment. You should also employ all other safety precautions necessary for the operation of the equipment in your operating environment. Failure to comply with these precautions or with specific warnings elsewhere in this manual could result in personal injury or damage to the equipment.

SMART Embedded Computing intends to provide all necessary information to install and handle the product in this manual. Because of the complexity of this product and its various uses, we do not guarantee that the given information is complete. If you need additional information, ask your SMART EC representative.

The product has been designed to meet the standard industrial safety requirements. It must not be used except in its specific area of office telecommunication industry and industrial control.

Only personnel trained by SMART EC or persons qualified in electronics or electrical engineering are authorized to install, remove or maintain the product.

The information given in this manual is meant to complete the knowledge of a specialist and must not be used as replacement for qualified personnel. Keep away from live circuits inside the equipment. Operating personnel must not remove equipment covers. Only factory authorized service personnel or other qualified service personnel may remove equipment covers for internal subassembly or component replacement or any internal adjustment.

Do not install substitute parts or perform any unauthorized modification of the equipment or the warranty may be voided. Contact your local SMART EC representative for service and repair to make sure that all safety features are maintained.

Electrical Interference

This equipment has been tested and found to comply with the limits for a Class A digital device, pursuant to Part 15 of the FCC Rules. These limits are designed to provide reasonable protection against harmful interference when the equipment is operated in a commercial environment. This equipment generates, uses, and can radiate radio frequency energy and, if not installed and used in accordance with the instruction manual, may cause harmful interference to radio communications.

Operation of this equipment in a residential area is likely to cause harmful interference in which case the user will be required to correct the interference at his own expense. Changes or modifications not expressly approved by SMART EC could void the user's authority to operate the equipment. Board products are tested in a representative system

to show compliance with the above mentioned requirements. A proper installation in a compliant system will maintain the required performance. Use only shielded cables when connecting peripherals to assure that appropriate radio frequency emissions compliance is maintained.

Installation

Damage of the RTM and Additional Devices and Modules

Incorrect installation or removal of additional devices or modules may damage the RTM or the additional devices or modules.

Before installing or removing additional devices or modules, read the respective documentation.

Damage of Circuits

Electrostatic discharge and incorrect installation and removal of the RTM can damage circuits or shorten its life.

Before touching the RTM or electronic components, make sure that you are working in an ESD-safe environment.

Damage of the RTM

Incorrect installation of the RTM can cause damage of the RTM.

Only use handles when installing/removing the RTM to avoid damage/deformation to the face plate and/or PCB.

Damage to RTM/Backplane or System Components

Bent pins or loose components can cause damage to the RTM, the backplane, or other system components.

Therefore, carefully inspect the RTM and the backplane for both pin and component integrity before installation.

SMART EC and our suppliers take significant steps to ensure there are no bent pins on the backplane or connector damage to the blades/RTMs prior to leaving the factory. Bent pins caused by improper installation or by inserting blades with damaged connectors could void the SMART EC warranty for the backplane or blades.

Operation

Damage of the RTM

High humidity and condensation on the RTM surface causes short circuits.

Do not operate the RTM outside the specified environmental limits. Make sure the RTM is completely dry and there is no moisture on any surface before applying power.

Environment

Always dispose of used blades, system components and RTMs according to your country's legislation and manufacturer's instructions.

Sicherheitshinweise

Dieses Kapitel enthält Hinweise, die potentiell gefährlichen Prozeduren innerhalb dieses Handbuchs vorrangestellt sind. Beachten Sie unbedingt in allen Phasen des Betriebs, der Wartung und der Reparatur des Systems die Anweisungen, die diesen Hinweisen enthalten sind. Sie sollten außerdem alle anderen Vorsichtsmaßnahmen treffen, die für den Betrieb des Produktes innerhalb Ihrer Betriebsumgebung notwendig sind. Wenn Sie diese Vorsichtsmaßnahmen oder Sicherheitshinweise, die an anderer Stelle dieses Handbuchs enthalten sind, nicht beachten, kann das Verletzungen oder Schäden am Produkt zur Folge haben.

SMART Embedded Computing ist darauf bedacht, alle notwendigen Informationen zum Einbau und zum Umgang mit dem Produkt in diesem Handbuch bereit zu stellen. Da es sich jedoch um ein komplexes Produkt mit vielfältigen Einsatzmöglichkeiten handelt, können wir die Vollständigkeit der im Handbuch enthaltenen Informationen nicht garantieren. Falls Sie weitere Informationen benötigen sollten, wenden Sie sich bitte an die für Sie zuständige Geschäftsstelle von SMART EC.

Das System erfüllt die für die Industrie geforderten Sicherheitsvorschriften und darf ausschließlich für Anwendungen in der Telekommunikationsindustrie und im Zusammenhang mit Industriesteuerungen verwendet werden.

Einbau, Wartung und Betrieb dürfen nur von durch SMART EC ausgebildetem oder im Bereich Elektronik oder Elektrotechnik qualifiziertem Personal durchgeführt werden. Die in diesem Handbuch enthaltenen Informationen dienen ausschließlich dazu, das Wissen von Fachpersonal zu ergänzen, können dieses jedoch nicht ersetzen.

Halten Sie sich von stromführenden Leitungen innerhalb des Produktes fern. Entfernen Sie auf keinen Fall Abdeckungen am Produkt. Nur werksseitig zugelassenes Wartungspersonal oder anderweitig qualifiziertes Wartungspersonal darf Abdeckungen entfernen, um Komponenten zu ersetzen oder andere Anpassungen vorzunehmen.

Installieren Sie keine Ersatzteile oder führen Sie keine unerlaubten Veränderungen am Produkt durch, sonst verfällt die Garantie. Wenden Sie sich für Wartung oder Reparatur bitte an die für Sie zuständige Geschäftsstelle von SMART EC. So stellen Sie sicher, dass alle sicherheitsrelevanten Aspekte beachtet werden.

EMV

Das Produkt wurde in einem SMART EC Standard system getestet. Es erfüllt die für digitale Geräte der Klasse A gültigen Grenzwerte in einem solchen System gemäß den FCC-Richtlinien Abschnitt 15 bzw. EN 55022 Klasse A. Diese Grenzwerte sollen einen angemessenen Schutz vor Störstrahlung beim Betrieb des Produktes in Gewerbe- sowie Industriegebieten gewährleisten.

Das Produkt arbeitet im Hochfrequenzbereich und erzeugt Störstrahlung. Bei unsachgemäßem Einbau und anderem als in diesem Handbuch beschriebenen Betrieb können

Störungen im Hochfrequenzbereich auftreten.

Warnung! Dies ist eine Einrichtung der Klasse A. Diese Einrichtung kann im Wohnbereich Funkstörungen verursachen. In diesem Fall kann vom Betreiber verlangt werden, angemessene Maßnahmen durchzuführen.

Installation

Beschädigung des RTMs und von Zusatzmodulen

Fehlerhafte Installation von Zusatzmodulen, kann zur Beschädigung des RTMs und der Zusatzmodule führen.

Lesen Sie daher vor der Installation von Zusatzmodulen die zugehörige Dokumentation.

Beschädigung von Schaltkreisen

Elektrostatische Entladung und unsachgemäßer Ein- und Ausbau von Blades/RTMs kann Schaltkreise beschädigen oder ihre Lebensdauer verkürzen. Bevor Sie Blades/RTMs oder elektronische Komponenten berühren, vergewissern Sie sich, dass Sie in einem ESD-geschützten Bereich arbeiten.

Beschädigung des RTMs

Fehlerhafte Installation des RTMs kann zu einer Beschädigung des RTMs führen.

Verwenden Sie die Handles, um das RTM zu installieren/deinstallieren. Auf diese Weise vermeiden Sie, dass das Face Plate oder die Platine deformiert oder zerstört wird.

Beschädigung des RTMs, der Backplane oder von System Komponenten

Verbogene Pins oder lose Komponenten können zu einer Beschädigung des RTMs, der Backplane oder von Systemkomponenten führen.

Überprüfen Sie daher das RTM sowie die Backplane vor der Installation sorgfältig und stellen Sie sicher, dass sich beide in einwandfreien Zustand befinden und keine Pins verbogen sind.

SMART EC und unsere Zulieferer unternehmen größte Anstrengungen um sicherzustellen, dass sich Pins und Stecker von Blades/RTMs vor dem Verlassen der Produktionsstätte in einwandfreiem Zustand befinden. Verbogene Pins, verursacht durch fehlerhafte Installation oder durch Installation von Blades/RTMs mit beschädigten Steckern kann die durch SMART EC gewährte Garantie für Blades und Backplanes erlöschen lassen.

Betrieb

Beschädigung des Blades

Die RJ-45-Stecker an der Frontblende sind für Anschlüsse vom Typ Twisted-Pair Ethernet (TPE) oder E1/T1/J1 vorgesehen. Der Anschluss eines E1/T1/J1-Interfaces an einen Ethernet-Stecker kann zur Zerstörung des Blades führen.

- Stellen Sie daher sicher, dass TPE-Stecker an Ihrem Arbeitsplatz eindeutig als Netzwerkstecker gekennzeichnet sind.
- Stellen Sie sicher, dass die Länge eines Kabels, welches an den RJ-45-Stecker angeschlossen ist, 100 m nicht überschreitet.
- Stellen Sie sicher, dass der TPE-Stecker ausschließlich mit einem Safety-Extra-Low-Voltage-Stromkreis (SELV) verbunden ist.
- Wenden Sie sich bei Fragen an ihren Systemadministrator

Beschädigung am Telefon

Die CH2 und CH3 Stecker sind mit einem durchgestrichenem Telefonhörer markiert. Wenn Sie an diese Stecker ein Telefon anschließen, kann Ihr Telefon beschädigt werden. Benutzen Sie für diese Stecker ausschließlich das CABLE-8001-CLK-3/10 Kabel.

Umweltschutz

Entsorgen Sie alte Batterien und/oder Blades/Systemkomponenten/RTMs stets gemäß der in Ihrem Land gültigen Gesetzgebung.

Introduction

The MVME721X Rear Transition Module (RTM) of the blade (hereinafter referred to as MVME721X-RTM) must work with MVME721X blades.

The MVME721X RTM is for I/O routing through the rear of a compact VMEbus chassis. It connects directly to the VME backplane in chassis with an 80mm deep rear transition area. The MVME721X RTM is desMVME721X RTM designed for use with the MVME7100, MVME2500, iVME7210, and MVME4100.

1.1 Features

The main features of the MVME721X RTM are as follows:

- One five-row P2 backplane connector for serial and Ethernet I/O passed from the SBC
- Four RJ-45 connectors for rear panel I/O: four asynchronous serial channels
- Two RJ-45 connectors with integrated LEDs for rear panel I/O: two 10/100/1000 Ethernet channels
- One PIM site with rear panel I/O

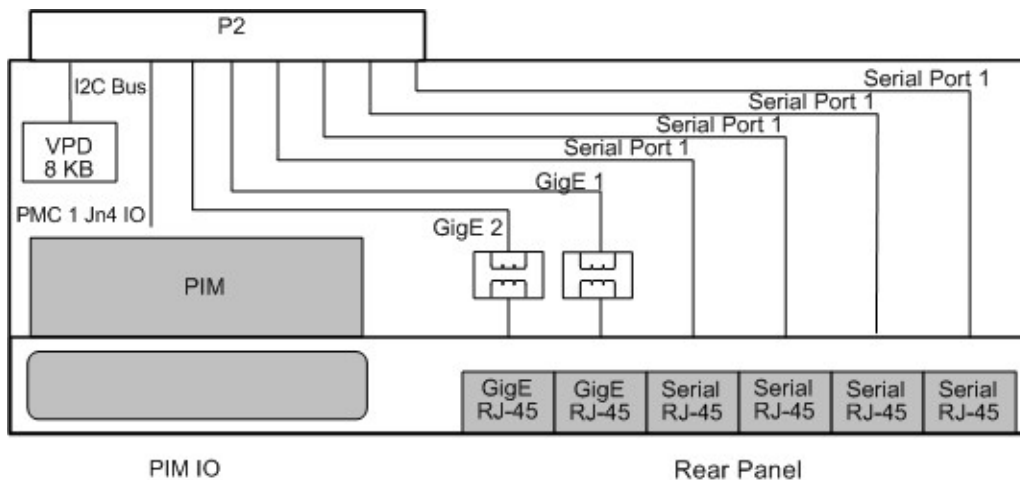

1.2 Rear Transition Module Layout

The following illustration shows the component layout and connectors on the MVME721X RTM.

Figure 1-1 Component Layout

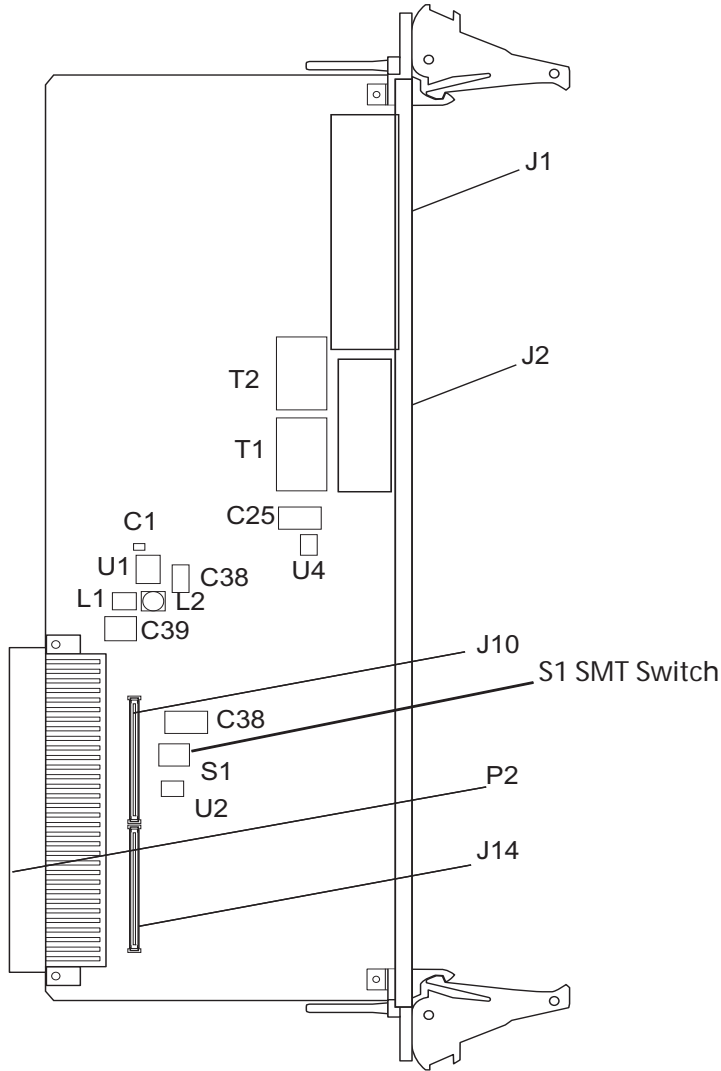

1.3 Standard Compliances

The product is designed to meet the following standards:

Table 1-1 Standard Compliances

Standard	Description
UL 60950-1 EN 60950-1 IEC 60950-1 CAN/CSA C22.2 No 60950-1	Safety Requirements (legal)
CISPR 22 CISPR 24 EN 55022 EN 55024 FCC Part 15 Industry Canada ICES-003 VCCI Japan AS/NZS CISPR 22 EN 300 386 NEBS Standard GR-1089 CORE	EMC requirements (legal) on system level (predefined SMART Embedded Computing system)
NEBS Standard GR-63-CORE ETSI EN 300 019 series	Environmental Requirements
Directive (EU) 2015/863 (amending Annex II to Directive 2011/65/EU)	Directive on the restriction of the use of certain hazardous substances in electrical and electronic equipment (RoHS)

1.4 Mechanical Data

Table 1-2 Mechanical Data

Data	Value
Dimensions (Width x Height x Depth)	20.32mm x 233.44mm x 80mm
Weight	226g

1.5 Ordering Information

Refer to the data sheets for the MVME7100 Single Board Computer for a complete list of available variants and accessories. Refer to [Appendix A, Related Documentation](#) or consult your local SMART EC sales representative for the availability of other variants.

Hardware Preparation and Installation

2.1 Introduction

This chapter describes the preparation before installing the RTM, the applicable environmental and power requirements, and the actual installation and removal of the RTM.

2.2 Unpacking and Inspecting the RTM

Use ESD protection



Damage of Circuits

Electrostatic discharge and incorrect installation and removal of the blade can damage circuits or shorten its life.

Before touching the blade or electronic components, make sure that you are working in an ESD-safe environment.

Shipment Inspection

To inspect the shipment, perform the following steps:

1. Verify that you have received all items of your shipment:

- MVME721X RTM
- One printed copy of *Quick Start Guide*
- One printed copy of *Safety Notes Summary*
- Any other items ordered

2. Check your shipment and report any damage or differences.

For technical assistance, documentation, or to report product damage or shortages, contact your local SMART Embedded Computing sales representative or visit <https://www.smartembedded.com/ec/support/>

3. Remove the desiccant bag shipped together with the RTM and dispose of it according to your country's legislation.

Important Information

The RTM is thoroughly inspected before shipment. If damage has occurred or items are missing during transportation, contact our customer service immediately.

Remove the desiccant bag shipped together with the RTM and dispose of it according to your country's legislation.

Requirements

2.3 Requirements

To meet the environmental requirements, the RTM has to be tested in the system in which it is to be installed.

2.3.1 Environmental Requirements

The environmental conditions must be tested and proven in the shelf configuration used. The conditions refer to the surroundings of the RTM within the user environment.

Before you power up the RTM, calculate the power needed according to your combination of blade upgrades and accessories.



The environmental requirements of the blade may be further limited down due to installed accessories, such as hard disks or PIM modules, with more restrictive environmental requirements.

Operating temperatures refer to the temperature of the air circulating around the blade and not to the actual component temperature.



Blade Damage

Blade Surface

Do not operate outside the specified environmental limits. Make sure the blade is completely dry and there is no moisture on any surface before applying power.

Blade Overheating and Blade Damage

Operating the blade without forced air cooling may lead to blade overheating and thus blade damage.

When operating the blade, make sure that forced air cooling is available in the shelf.

Table 2-1 Environmental Conditions

Characteristics	Operating	Non-Operating
Operating temperature	0°C to +55°C (32°F to 131°F) entry air with forced-air cooling	-40°C to +85° C (-40°F to 185°F)
	-40°C to +71°C (ET version)	-50°C to +100°C (ET version)
Temperature change	+/-0.5° C/min according to NEBS Standard GR-63-CORE	
Relative humidity	5% to 90% non-condensing	5% to 90% non-condensing

Table 2-1 Environmental Conditions (continued)

Characteristics	Operating	Non-Operating
Vibration	1 G sine sweep, 5 - 200Hz, with a sweep rate of 0.25 octaves/minute in three mutually perpendicular axis	

2.4 RTM Installation and Removal

The MVME721X RTM does not support hot swap. You should remove power to the rear slot or system before installing the module. Before installing the MVME721X RTM, you may need to manually configure the switch and install a PMC I/O Module (PIM). Refer to [Chapter 3, Controls, LEDs, and Connectors](#) for switch settings and PIM installation.

<p>Use ESD protection</p> 	<p>Damage of Circuits</p> <p>Electrostatic discharge and incorrect RTM installation and removal can damage circuits or shorten its life.</p> <p>Before touching the RTM or electronic components, make sure that you are working in an ESD-safe environment.</p>
--	---

	<p>Damage of the RTM</p> <p>Incorrect installation of the RTM can cause damage to the RTM.</p> <p>Only use handles when installing or removing the RTM to avoid damage/deformation to the face plate and/or the PCB.</p>
--	---

2.4.1 PMC I/O Module (PIM) Installation

NOTE: If a PMC I/O Module (PIM) has already been installed on the MVME721X RTM or if you are installing an RTM as it has been shipped from the factory, disregard this procedure.

For PIM installation, perform the following steps:

1. Attach an ESD strap to your wrist. Attach the other end of the ESD strap to the chassis as a ground. The ESD strap must be secured to your wrist and the chassis to ground throughout the procedure.
2. Carefully remove the RTM from its packaging and lay it flat on a stable surface.
3. Remove the PIM filler from the front panel of the RTM.

PMC I/O Module (PIM) Installation

- Slide the face plate (front bezel) of the PIM module into the front panel opening from behind and place the PIM module on top of the RTM, aligned with the appropriate two PIM connectors. The two connectors on the underside of the PIM module should then connect smoothly with the corresponding connectors on the RTM (J10 and J14).
- Insert the four short Phillips screws (provided with the PIM) through the holes on the bottom side of the RTM into the PIM front bezel and rear standoffs. Tighten the screws.

For more information on PIM connectors and its signals, see [PMC Input/Output Module \(PIM\) Connectors \(J10/J14\)](#) on page 37.

Figure 2-1 Installing the PIM

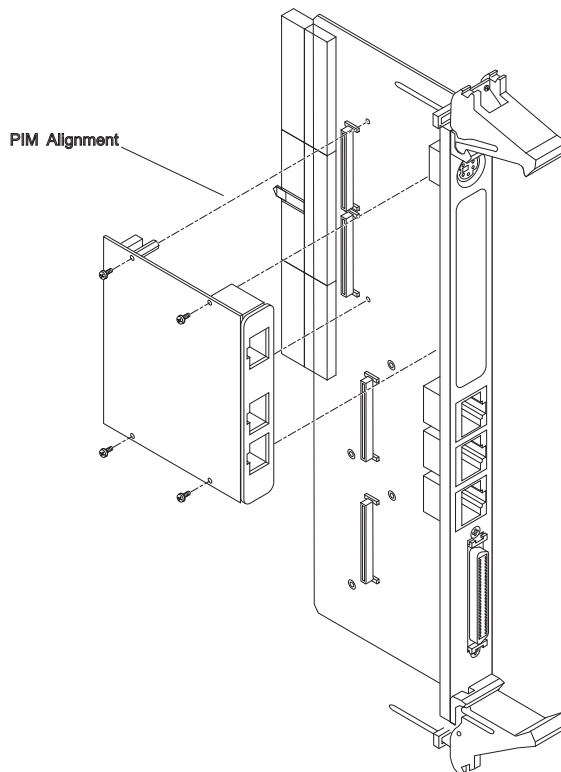

2.4.2 Installing the RTM

To begin the installation of the RTM in a chassis, proceed as follows:

Installing the RTM with IEEE Handles

1. Attach an ESD strap to your wrist. Attach the other end of the ESD strap to the chassis as a ground. The ESD strap must be secured to your wrist and the chassis to ground throughout the procedure.
2. Turn all equipment power OFF and disconnect the power cable from the AC power source.
3. Remove the chassis cover as instructed in the equipment user's manual.
4. Remove the filler panel(s) from the appropriate card slot(s) at the rear of the chassis (if the chassis has a rear card cage).
5. Install the top and bottom edge of the RTM into the rear guides of the chassis.
6. Ensure that the IEEE handles are in the outward position.

Figure 2-2 IEEE Handles

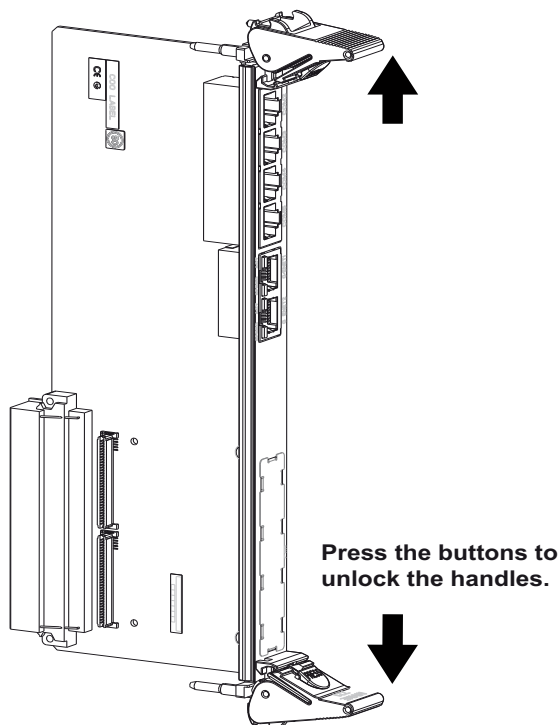

Installing the RTM

- Slide the RTM into the chassis until resistance is felt.

Figure 2-3 IEEE Handles

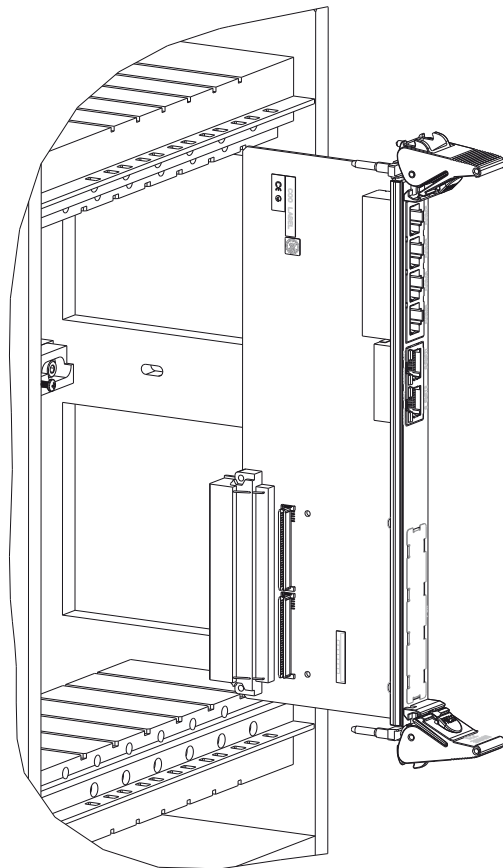

8. Simultaneously move the handles in an inward direction to lock the RTM to the chassis.

Figure 2-4 IEEE Handles

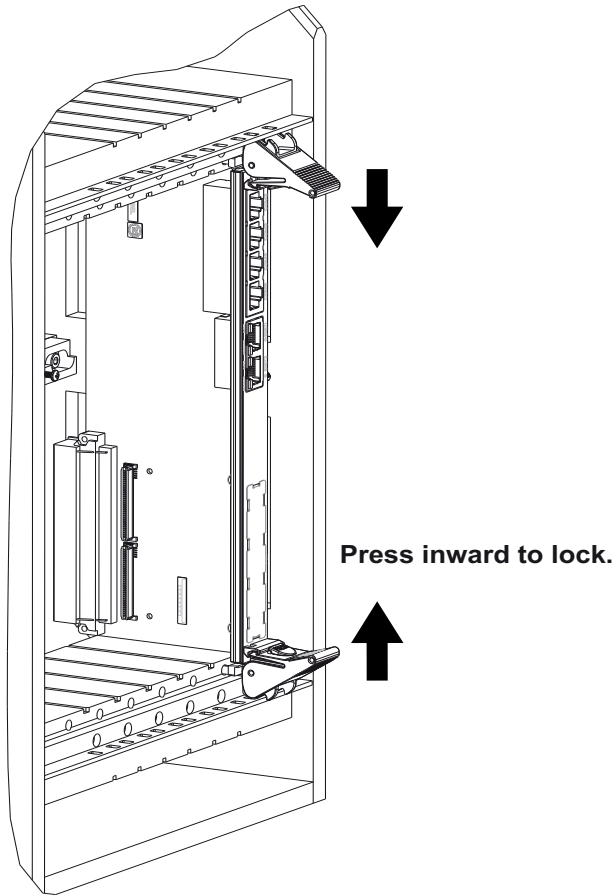

Installing the RTM

9. Verify that the RTM is properly seated and secure it to the chassis using the two screws located adjacent to the IEEE handles.

Figure 2-5 IEEE Handles

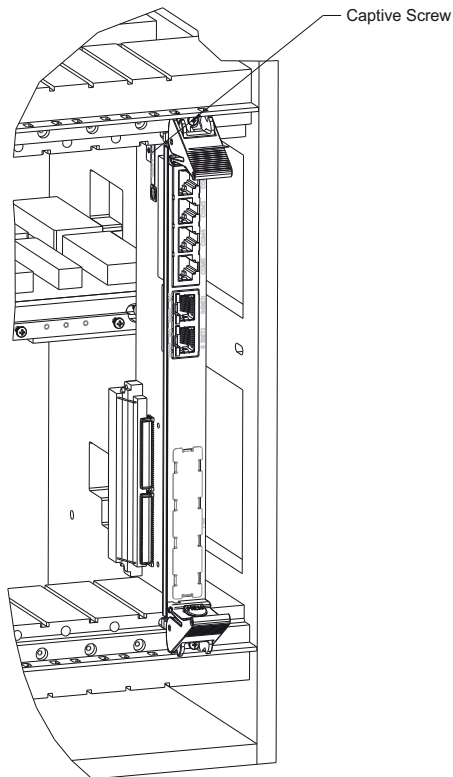

10. Connect the appropriate cables to the RTM.



Make sure that the handles of both the RTM and the front blade are closed in order to power up the blade and RTM payload.

Installing the RTM with Scanbe Handles

1. Attach an ESD strap to your wrist. Attach the other end of the ESD strap to the chassis as a ground. The ESD strap must be secured to your wrist and the chassis to ground throughout the procedure.
2. Turn all equipment power OFF and disconnect the power cable from the AC power source.

3. Remove the chassis cover as instructed in the equipment user's manual.
4. Remove the filler panel(s) from the appropriate card slot(s) at the rear of the chassis (if the chassis has a rear card cage).
5. Install the top and bottom edge of the RTM into the rear guides of the chassis.
6. Ensure that the Scanbe handles are in the outward position.

Figure 2-6 Scanbe Handles

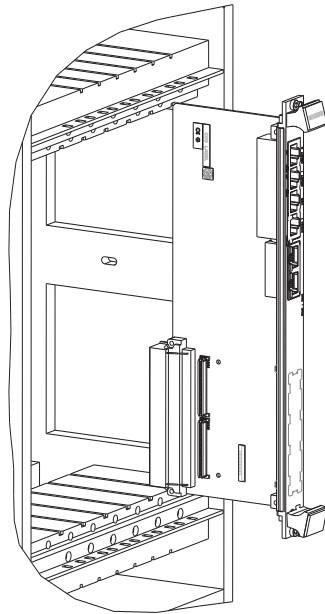

7. Slide the RTM into the chassis until resistance is felt.
8. Carefully seat the RTM into the chassis by applying firm pressure to the RTM front panel, near the Scanbe handles.

NOTE: Scanbe handles cannot be used for card injection. Scanbe handles are for ejection purposes only.

9. Verify that the RTM is properly seated and secure it to the chassis using the two screws located adjacent to the Scanbe handles.
10. Connect the appropriate cables to the RTM.

Removing the RTM



Make sure that the handles of both the RTM and the front blade are closed in order to power up the blade and RTM payload.

2.4.3 Removing the RTM

1. Attach an ESD strap to your wrist. Attach the other end of the ESD strap to the chassis as a ground. The ESD strap must be secured to your wrist and the chassis to ground throughout the procedure.
2. Turn off the power.
3. Disconnect the appropriate cables from the RTM.
4. Unfasten the screws located adjacent to the handles.
5. Fully open the upper and lower handles in outward direction.
6. Hold top and bottom edges of the RTM and exert minimal force when pulling RTM from the chassis to prevent pin damage.
7. Slide the RTM from the rear guides of the chassis.
8. Carefully remove the RTM from the chassis and store in an anti-static envelope.
9. Install the filler panel into the appropriate slots at the rear of the chassis.

Controls, LEDs, and Connectors

3.1 Overview

This chapter describes:

- SEEPROM Address switch, S1
- Rear panel connectors and LEDs
- FRU serial EEPROM

3.2 SEEPROM Address Switch, S1

A 4-position SMT configuration switch is located on the MVME721X RTM to set the device address of the RTM serial EEPROM device. The switch settings are defined in the next table.

Figure 3-1 S1 Switch Positions

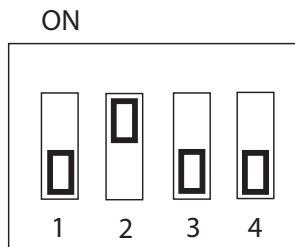

Table 3-1 SEEPROM Address Switch Assignments (RTM)

Position	SW4	SW3	SW2	SW1
Function	WP	A(2)	A(1)	A(0)
Default (OFF)	0	1	1	1

Table 3-2 Switch Settings and Device Addresses

SW4	SW3	SW2	SW1	A(2-0)	Device Address
OFF	ON	ON	ON	000	\$A0
OFF	ON	ON	OFF	001	\$A2
OFF	ON	OFF	ON	010	\$A4
OFF	ON	OFF	OFF	011	\$A6

Rear Panel Connectors and LEDs

Table 3-2 Switch Settings and Device Addresses (continued)

SW4	SW3	SW2	SW1	A(2-0)	Device Address
OFF	OFF	ON	ON	100	\$A8
OFF	OFF	ON	OFF	101	\$AA (default)
OFF	OFF	OFF	ON	110	\$AC
OFF	OFF	OFF	OFF	111	\$AE

3.3 Rear Panel Connectors and LEDs

The MVME721X RTM provides the following connectors and LEDs.

Figure 3-2 Rear Panel Connectors and LEDs

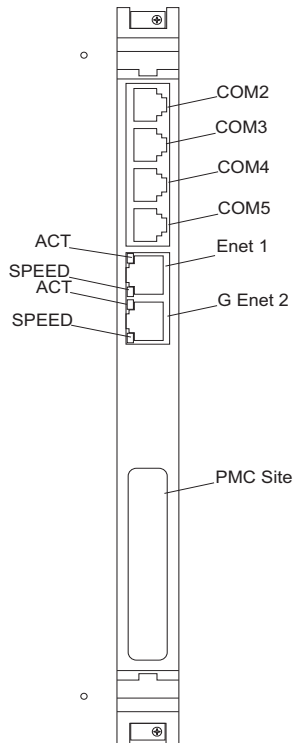

3.3.1 Rear Panel Connectors

All connectors use standard pin assignments in compliance with the VMEbus specifications:

Table 3-3 Transition Module Connectors

Connector	Function
J1A, J1B, J1C, J1D	COM port connectors
J2A	10/100/1000Mb/s Ethernet connector
J2B	10/100/1000Mb/s Ethernet connector
J10	PIM power/ground
J14	PIM I/O
P2	VME backplane connector

3.3.1.1 J1 (Serial) and J2 (Ethernet) Pinout Connectors

The pin assignments for the J1 and J2 connectors are as follows:

Table 3-4 J1 and J2 Connector Pin Assignments

J1		J2	
Pin Name	Signal Description	Pin Name	Signal Description
A1	NC	A1	E2_0P
A2	SP4_RTS	A2	E2_0N
A3	GND	A3	E2_1P
A4	SP4_TX	A4	E2_1N
A5	SP4_RX	A5	E2_2P
A6	GND	A6	E2_2N
A7	SP4_CTS	A7	E2_3P
A8	NC	A8	E2_3N
B1	NC	B1	E1_0P
B2	SP3_RTS	B2	E1_0N

Rear Panel Connectors

Table 3-4 J1 and J2 Connector Pin Assignments (continued)

J1		J2	
Pin Name	Signal Description	Pin Name	Signal Description
B3	GND	B3	E1_1P
B4	SP3_TX	B4	E1_1N
B5	SP3_RX	B5	E1_2P
B6	GND	B6	E1_2N
B7	SP3_CTS	B7	E1_3P
B8	NC	B8	E1_3N
C1	NC		
C2	SP2_RTS		
C3	GND		
C4	SP2_TX		
C5	SP2_RX		
C6	GND		
C7	SP2_CTS		
C8	NC		
D1	NC		
D2	SP1_RTS		
D3	GND		
D4	SP1_TX		
D5	SP1_RX		
D6	GND		
D7	SP1_CTS		
D8	NC		

3.3.1.2 PMC Input/Output Module (PIM) Connectors (J10/J14)

The pin assignments for the J10 and J14 connectors are as follows:

Table 3-5 J10 Connector Pin Assignments

PMC (J10)			
Pin Name	Signal Description	Pin Name	Signal Description
1	NC	33	NC
2	NC	34	GND
3	NC	35	NC
4	NC	36	NC
5	+5V	37	+5V
6	NC	38	NC
7	NC	39	NC
8	NC	40	NC
9	NC	41	NC
10	+3.3V	42	+3.3V
11	NC	43	NC
12	NC	44	NC
13	GND	45	GND
14	NC	46	NC
15	NC	47	NC
16	NC	48	NC
17	NC	49	NC
18	GND	50	GND
19	NC	51	NC
20	NC	52	NC
21	+5V	53	+5V

Rear Panel Connectors

Table 3-5 J10 Connector Pin Assignments (continued)

PMC (J10)			
Pin Name	Signal Description	Pin Name	Signal Description
22	NC	54	NC
23	NC	55	NC
24	NC	56	NC
25	NC	57	NC
26	+3.3V	58	+3.3V
27	NC	59	NC
28	NC	60	NC
29	GND	61	NC
30	NC	62	NC
31	NC	63	NC
32	NC	64	NC

Table 3-6 J14 Connector Pin Assignments

PMC (J14)			
Pin Name	Signal Description	Pin Name	Signal Description
1	PMC_IO_1	33	PMC_IO_33
2	PMC_IO_2	34	PMC_IO_34
3	PMC_IO_3	35	PMC_IO_35
4	PMC_IO_4	36	PMC_IO_36
5	PMC_IO_5	37	PMC_IO_37
6	PMC_IO_6	38	PMC_IO_38
7	PMC_IO_7	39	PMC_IO_39
8	PMC_IO_8	40	PMC_IO_40

Table 3-6 J14 Connector Pin Assignments (continued)

PMC (J14)			
Pin Name	Signal Description	Pin Name	Signal Description
9	PMC_IO_9	41	PMC_IO_41
10	PMC_IO_10	42	PMC_IO_42
11	PMC_IO_11	43	PMC_IO_43
12	PMC_IO_12	44	PMC_IO_44
13	PMC_IO_13	45	PMC_IO_45
14	PMC_IO_14	46	PMC_IO_46
15	PMC_IO_15	47	PMC_IO_47
16	PMC_IO_16	48	PMC_IO_48
17	PMC_IO_17	49	PMC_IO_49
18	PMC_IO_18	50	PMC_IO_50
19	PMC_IO_19	51	PMC_IO_51
20	PMC_IO_20	52	PMC_IO_52
21	PMC_IO_21	53	PMC_IO_53
22	PMC_IO_22	54	PMC_IO_54
23	PMC_IO_23	55	PMC_IO_55
24	PMC_IO_24	56	PMC_IO_56
25	PMC_IO_25	57	PMC_IO_57
26	PMC_IO_26	58	PMC_IO_58
27	PMC_IO_27	59	PMC_IO_59
28	PMC_IO_28	60	PMC_IO_60
29	PMC_IO_29	61	PMC_IO_61
30	PMC_IO_30	62	PMC_IO_62

Rear Panel Connectors

Table 3-6 J14 Connector Pin Assignments (continued)

PMC (J14)			
Pin Name	Signal Description	Pin Name	Signal Description
31	PMC_IO_31	63	PMC_IO_63
32	PMC_IO_32	64	PMC_IO_64

PMC Input/Output Module (PIM) connector J10 routes only power and ground from VME P2 connector. There are no host I/O signals on this connector. The front board routes the PIM from J14 of PMC Slot 1 to VME P2 rows A and C. The MVME721X RTM routes these signals (pin-for-pin) from VME P2 to PMC I/O module connector J14.

For installation procedure of PIM, see [PMC I/O Module \(PIM\) Installation on page 25](#).

3.3.1.3 VME Backplane P2 Connector

The pin assignments for the P2 connector are as follows:

Table 3-7 VME Backplane P2 Connector Pin Assignments

P2 Connector					
Pin Name	Signal Description				
	Row A	Row B	Row C	Row D	Row Z
1	PMC IO 2	+5V	PMC IO 1	E1_1+	Serial 1 RX
2	PMC IO 4	GND	PMC IO 3	E1_1-	GND
3	PMC IO 6	RETRY	PMC IO 5	GND	Serial 1 TX
4	PMC IO 8	NC	PMC IO 7	E1_2+	GND
5	PMC IO 10	NC	PMC IO 9	E1_2-	Serial 1 CTS
6	PMC IO 12	NC	PMC IO 11	GND	GND
7	PMC IO 14	NC	PMC IO 13	E1_3+	Serial 1 RTS
8	PMC IO 16	NC	PMC IO 15	E1_3-	GND
9	PMC IO 18	NC	PMC IO 17	GND	Serial 2 RX
10	PMC IO 20	NC	PMC IO 19	E1_4+	GND
11	PMC IO 22	NC	PMC IO 21	E1_4-	Serial 2 TX

Table 3-7 VME Backplane P2 Connector Pin Assignments (continued)

P2 Connector					
Pin Name	Signal Description				
	Row A	Row B	Row C	Row D	Row Z
12	PMC IO 24	GND	PMC IO 23	GND	GND
13	PMC IO 26	+5V	PMC IO 25	I2C DATA	Serial 2 CTS
14	PMC IO 28	NC	PMC IO 27	I2C CLK	GND
15	PMC IO 30	NC	PMC IO 29	E1_LINK_LED	Serial 2 RTS
16	PMC IO 32	NC	PMC IO 31	E1_ACT_LED	GND
17	PMC IO 34	NC	PMC IO 33	E2_LINK_LED	Serial 3 RX
18	PMC IO 36	NC	PMC IO 35	E2_ACT_LED	GND
19	PMC IO 38	NC	PMC IO 37	GND	Serial 3 TX
20	PMC IO 40	NC	PMC IO 39	E2_4 -	GND
21	PMC IO 42	NC	PMC IO 41	E2_4 +	Serial 3 CTS
22	PMC IO 44	GND	PMC IO 43	GND	GND
23	PMC IO 46	NC	PMC IO 45	E2_3 -	Serial 3 RTS
24	PMC IO 48	NC	PMC IO 47	E2_3+	GND
25	PMC IO 50	NC	PMC IO 49	GND	Serial 4 RX
26	PMC IO 52	NC	PMC IO 51	E2_2 -	GND
27	PMC IO 54	NC	PMC IO 53	E2_2 +	Serial 4 TX
28	PMC IO 56	NC	PMC IO 55	GND	GND
29	PMC IO 58	NC	PMC IO 57	E2_1 -	Serial 4 CTS
30	PMC IO 60	NC	PMC IO 59	E2_2 +	GND
31	PMC IO 62	GND	PMC IO 61	GND	Serial 4 RTS
32	PMC IO 64	+5V	PMC IO 63	+5V	GND

LEDs

3.3.2 LEDs

There are two sets of ACT and SPEED LEDs, one set for each Ethernet connector. They are described in the next table. For LED positions, please see [Figure 3-2](#).

Table 3-8 Front Panel LEDs

Label	Location	Color	Description
GENET1 SPEED	Front panel Integrated RJ45 LED	Off Amber Green	No link 10/100BASE-T operation 1000 BASE-T operation
GENET1 ACT	Front panel Integrated RJ45 LED	Off Blinking Green	No activity Activity proportional to bandwidth utilization
GENET2 SPEED	Front panel Integrated RJ45 LED (Left)	Off Amber Green	No link 10/100BASE-T operation 1000BASE-T operation
GENET2 ACT	Front panel Integrated RJ45 LED	Off Blinking Green	No activity Activity proportional to bandwidth utilization

3.4 FRU Serial EEPROM

This serial EEPROM is intended to hold FRU data and any additional parameters that are required.

The MVME721X RTM provides a 64kB (8192 x 8 bits) I2C serial EEPROM. This is a 24C64D type device. The EEPROM resides at I2C address 0xA0 (default), this address can be changed by configuring the SW1 switch. Care must be taken when configuring this switch, it may cause an address conflict with the I2C device on the front board.

Related Documentation

A.1 SMART Embedded Computing Documentation

The documentation listed in *Table A-1* is referenced in this manual. Technical documentation can be found by using the Documentation Search at <https://www.smartembedded.com/ec/support/> or you can obtain electronic copies of SMART EC documentation by contacting your local sales representative.

Table A-1 SMART EC Documents

Document Title	Publication Number
MVME-7100 Single Board Computer Installation and Use	6806800E08
MVME7100 NXP MPC864xD VME SCB	MVME7100-DS
MVME-2500 Installation and Use	6806800L01
iVME-7210	6806800K32
MVME-4100 Single Board Computer Installation and Use	6806800H18

